

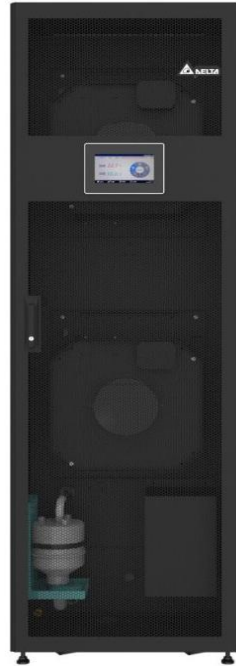

Delta InfraSuite Precision Cooling

RowCool series 12kW - 50kW
DX Air-Cooled (R410A)

Delta InfraSuite Precision Cooling



High Energy Efficiency

- Variable Speed Scroll compressor with DC inverter driven for best efficiency at full and part load.
- Variable EC fan for optimum air flow supplying.
- Electronics Expansion Valve provides precisely pressure control over wide temperature range.
- AC inverter driven outdoor fan, optional EC fan obtains max efficiency at all temperature condition.

Highly Manageability

- 7 inch Touch screen HMI
- Remote monitoring via MODBUS or SNMP available
- Remote display to support group monitoring.
- Top/bottom piping and electrical connection as standard.

High Availability

- Modular rack design readily expandable as required to enable quick configuration and eliminate hot spots.
- Team mode operation enhances redundancy level.
- Optional re-heater and humidifier accessories for more precise temperature and humidity control.
- Repair from front/rear and a discrete components design reduces checking and maintenance time.
- Low speed to keep compressor running at low loading and avoid frequent stop/start to ensure compressor life.
- Built-in oil separator supports both positive and negative height installation with less worry for outdoor unit piping distance.
- Optional built-in ATS to support 2N input for tier III reliability level.
- Optional Built-in drain pump unit

Delta InfraSuite Precision Cooling

DC INVERTER SCROLL COMPRESSOR

***Scroll compressor** technology obtains superior reliability with proven record and many application with highly efficient at full load and part load condition. Minimalist of fewest moving parts yields quiet operation noise and low vibration that might affect to IT Equipment insides datacentre room.

R-410A Refrigerant, environment friendly, provides more stable operation over wide outdoor temperature range.

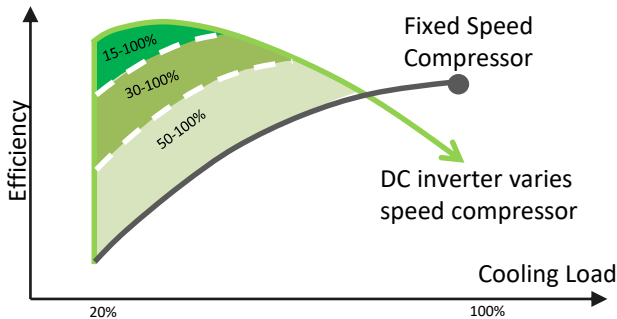
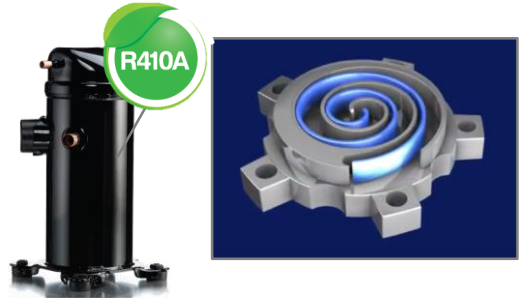

DC inverter Compressor, by using Brushless DC motor, its performance is improved by 20% to 40% over traditional AC motor compressor. Special rotor design minimize mechanical losses and reduces operation vibration and audible noise. Vibration suppressor brushing are equipped for further eliminating of vibration from compressor to avoid risk of damaging on IT equipment in Data Centre.

180° SINE WAVE VARIABLE SPEED DRIVE

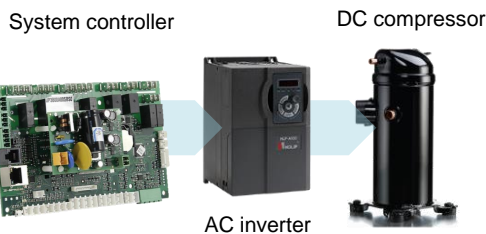

180° Sine wave DC Inverter driven technique with vectoring control ensures the output current of inverter to be a pure sine wave so that smooth rotation the permanent magnet rotor can be achieved. At the same time minimizes all harmonics current and electromagnetic interference.

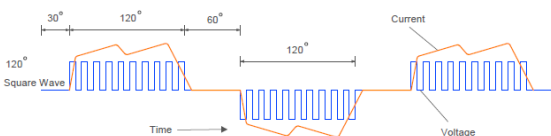

Conventional driven technique

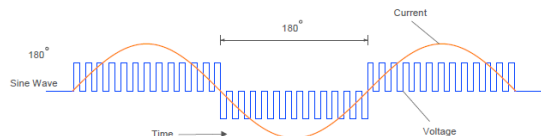

Delta 180° Sine Wave DC Inverter driven technique

Delta InfraSuite Precision Cooling

Electronically controlled expansion valve

The electronic expansion valve (EEV) controls flow of refrigerant entering a direct expansion evaporator. The system controller unit send control signal to open valve pin at precise step. The valve pin opening mechanism allows accurate control amount of vaporization expansion of refrigerant liquid so that the evaporator temperature can be controlled according to capacity needed by heat load, as well as, wider range of outdoor condenser can be achieved.

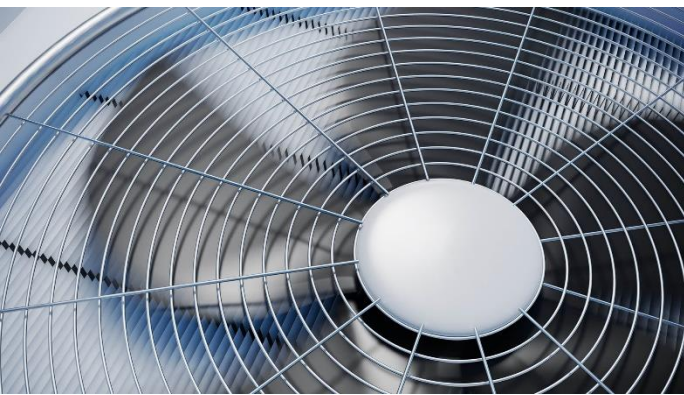
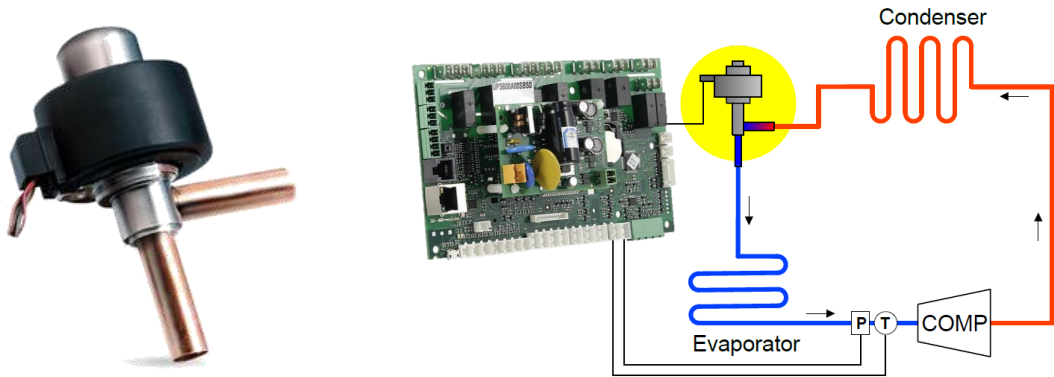

VARIABLE CONDENSER FAN SPEED CONTROL

Condenser fan speed is controlled by system controller through AC inverter drive according to actual heat load. This technique helps fan to work at optimum speed all the time so that it is most energy efficient, longer life span and with minimum audible noise. By the variable fan speed technique, its outdoor ambient operating temperature can be increased as high as 40° C without derating. Not only by AC inverter driven fan for your choice, an EC type condensing fan is an optional for selection to boost further efficiency of your cooling system.

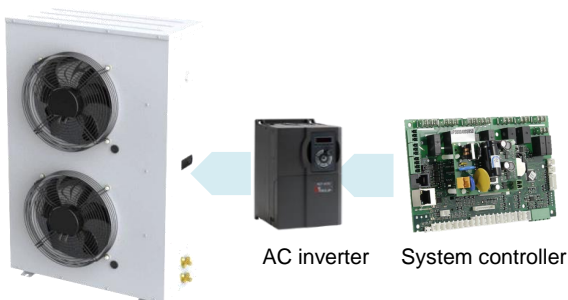

Delta InfraSuite Precision Cooling

INDOOR UNIT WITH BACKWARD CURVED EC FAN



Indoor air supplier fan are EC motor type which allows system controller to electronically adjust airflow from 0% to 100% according to capacity requirement of IT equipment in datacentre. Thanks to its variable speed technology, fans energy consumption can be reduced essentially obtaining best energy efficiency of datacentre.

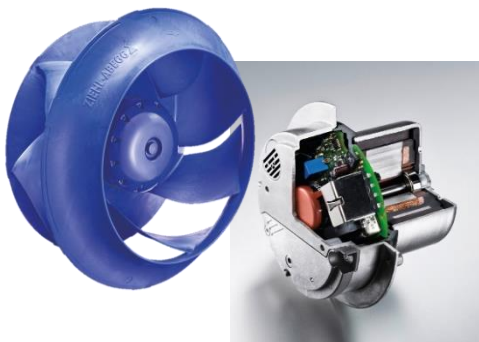
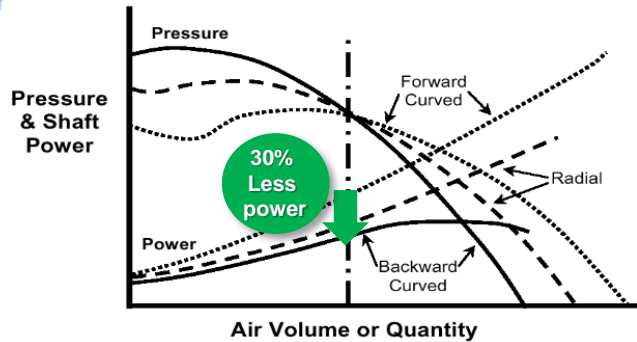

Backward centrifugal fan blade characterizes best P-Q performance at lowest power consumption among all other fan type. It keeps constant airflow volume and pressure to support heat removal needed for white space. Numbers of fans provides in system redundancy so that high availability of cooling system is satisfied.

Delta InfraSuite Precision Cooling

DISCRETE SYSTEM CONTROL UNIT



Discrete system controller, the heart of Delta RowCool product is a specific cooling system controller from world class cooling system components manufacturer. It helps to simplify all system design with best reliability supporting the RowCool to perform best accuracy on both temperature and humidity so that your Datacenter could be maximized its performance. DINRAIL mount platform obtains easy maintenance, shortest MTTR if there is any incident happening.

Network ready connection and built-in WEB server function makes you convenient to whether monitor or control via Ethernet network from anywhere you are. All parameter displays on the WEB is simultaneously reporting the same value with front display of the RowCool unit.

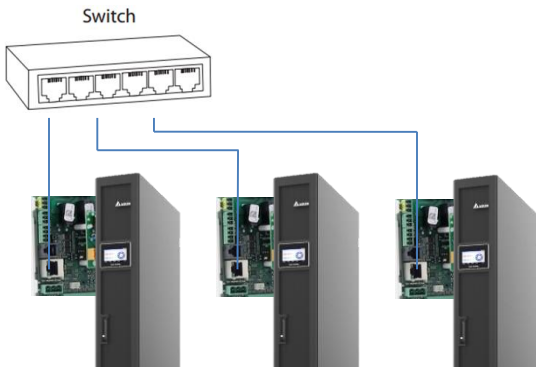
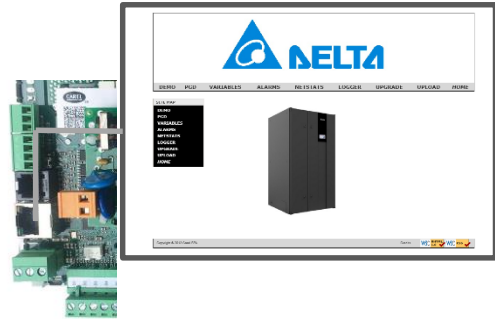

Team mode features support group control for redundancy and rotational operation. Remote display for the master RowCool in the group to the slave units can be archived via Ethernet network connection so that each user for no needing to walk to every cooling units in Datacentre room.



Delta InfraSuite Precision Cooling

EQUIPPED WITH INDUSTRIAL GRADE SENSORS

Pressure sensors

Both high-pressure check point and low-pressure check point has been equipped with industrial grade pressure sensors and feeds signal to system control for real time monitoring on gas pipe and liquid pipe. By this real time data from the sensor, not just a switch, they help system controller to precisely control all key system components, for instance, DC compressor, EEV, outdoor condenser work synergizing with no compromise for best efficiency and yet provides most safety operation for the compressor achieving longer life span.

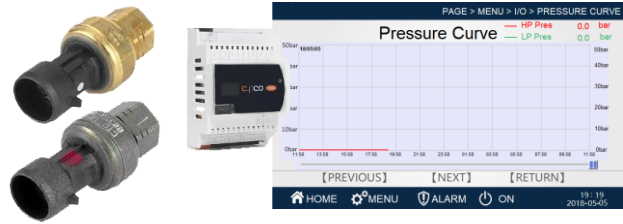

HP & LP sensors

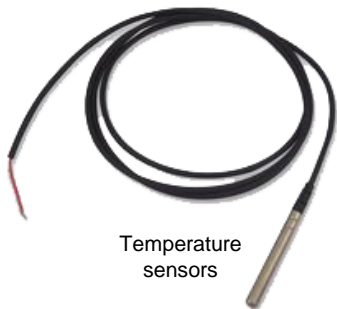

Temperature sensors

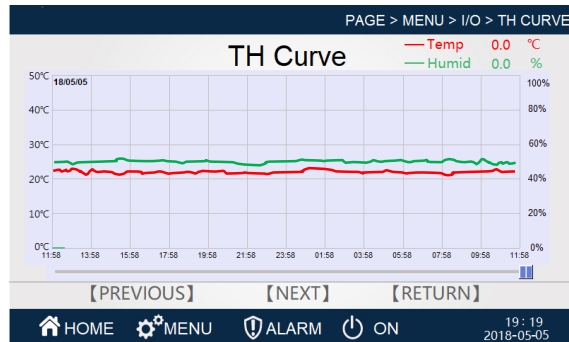

Dedicated Thermo-Hygrometer and industrial grade sensors

The high accuracy thermo-hygrometer is designed to monitor air quality to feedback to system controller. This professional sensing technique enhances the RowCool capability to supply best quality of air for IT equipment according to ASHRAE 2011 A1 guideline (18 C° to 27 C° and with humidity within range of 20% to 70%). The simple but effective passive type Positive Temperature Coefficient (PTC) sensor, PT100, is employed for both supply air temperature.

It is simple accurate highly reliable temperature sensing technique.



Air temperature and Humidity sensor

Delta InfraSuite Precision Cooling

USER FRIENDLY CONTROL PANEL

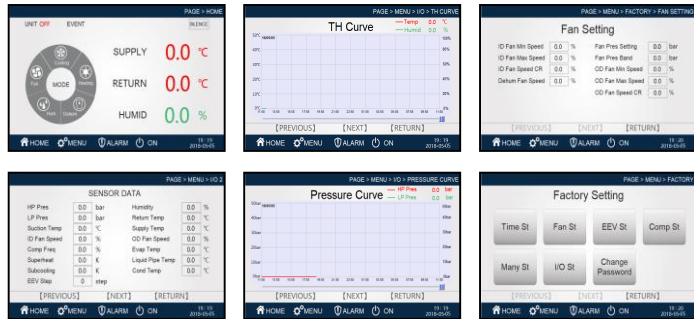

7 INCH COLOR TOUCH PANEL

Comprehensive parameter and detailed monitoring down to sub cool and super heat parameters via touch screen display simplifies maintenance, fault finding and reduces MTR, It supports multi language for user interface up to 8 languages.

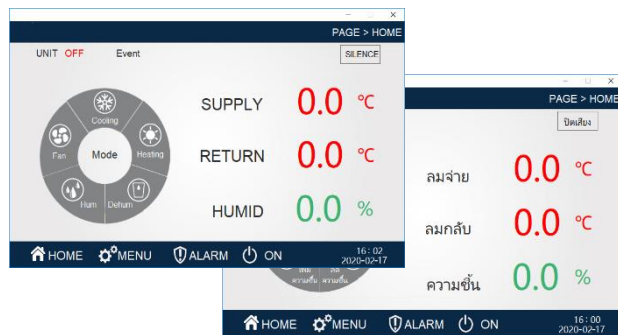

ACCESS AND SECURITY CONTROL

Delta RowCool has security and access control of machine monitoring, maintenance and setup provides high security and compliance to international datacentre standards



The power behind competitiveness



Delta InfraSuite Precision Cooling

EASY SERVICE DESIGN TOPOLOGY

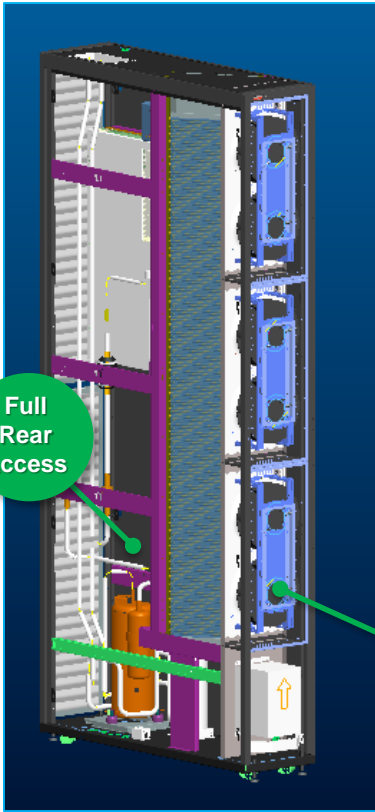

Full front/rear service access

Delta RowCool is designed for full access to key components from the front of the unit such as fans, inverter, drain pan and all refrigerant circuits at rear side such as compressor, oil separator, valves and sensors. This provides service personnel easy access to all key components in limited and restricted area of datacentre application.

Withdrawable control module

Provides convenient access to components for commissioning, preventative and corrective maintenance.

All components are DIN rail mounted to reduce the complexity of upgrades and repairs.



Built-in oil separator

The system can operate reliably and safely by use of built-in oil separator. It separates the lubricating oil mixed with the refrigerant after the compressor's compression to reduce amount of oil entering the refrigerant cycle. Then oil will be returned directly to the compressor and ensures sufficiently for compressor operation. Thus, by this oil control technique, the RowCool can support for both positive and negative condenser installation.

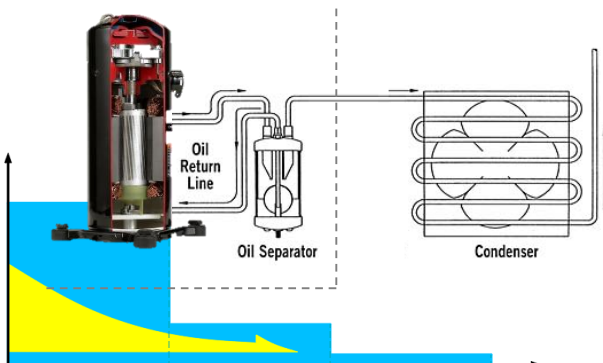

Delta InfraSuite Precision Cooling

Positive condenser unit positioning

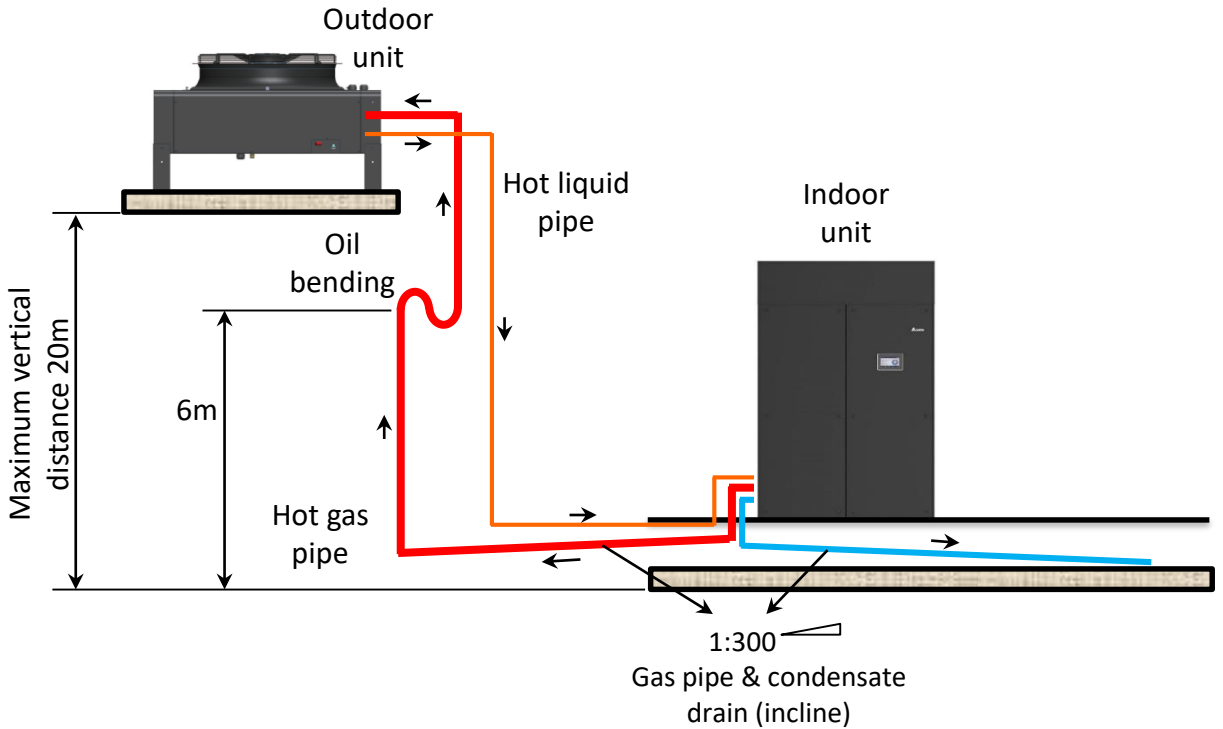

Negative condenser unit positioning

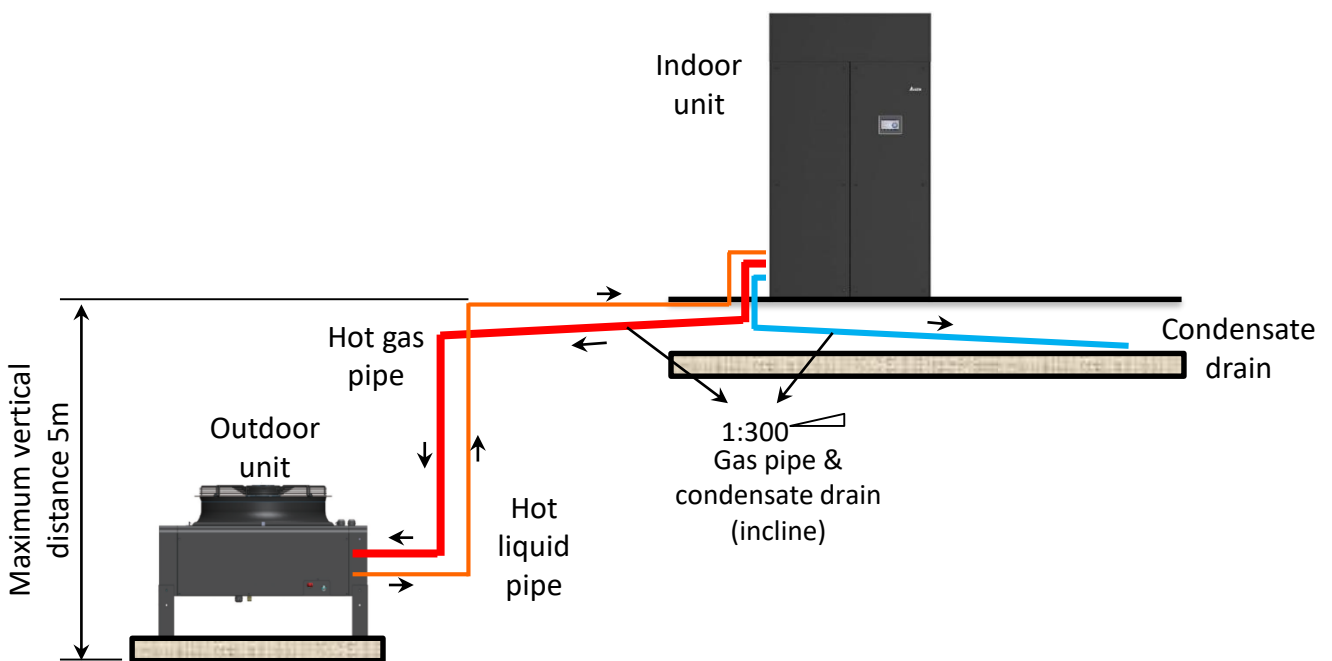

Delta InfraSuite Precision Cooling

EASY SERVICE DESIGN TOPOLOGY

Top/Bottom connection in single model, Delta RowCool is designed to with both top and bottom piping and cable entries for maximum flexibility, this simplifies the installation of electrical and communication cables refrigerant pipes, drainage pipe and supply water pipes on customer sites.

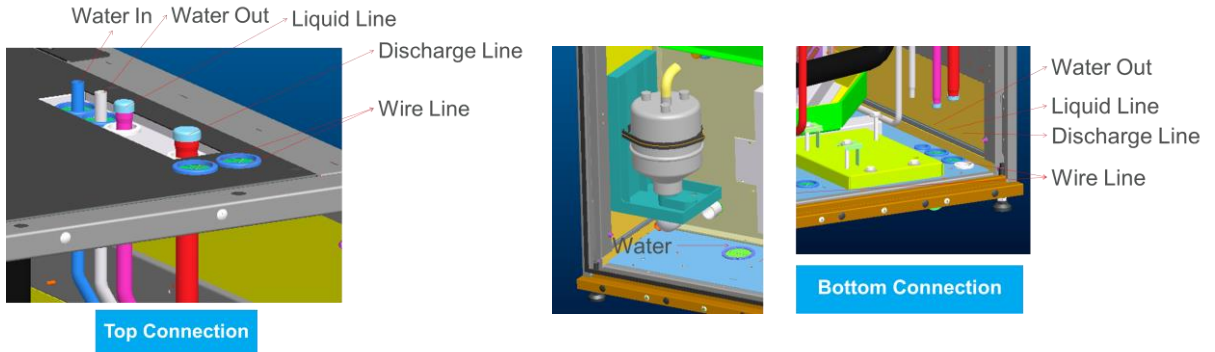

Automatic Transfer Switch

The ATS input power switch provides increased reliability flexibility in design allowing Delta RowCool to be deployed in various Tier and class rated facilities. The highly integrated design reduces the complexity in Data centre design and footprint of supporting electrical infrastructure.

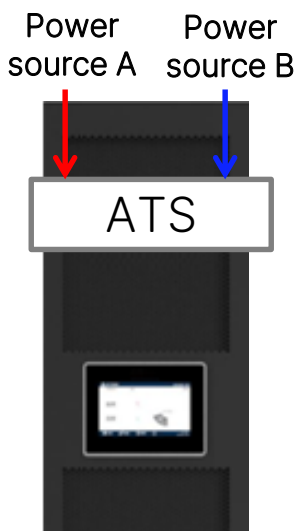

Delta InfraSuite Precision Cooling

INDUSTRIAL GRADE MATERIAL

Fire retardant heat insulation, Delta RowCool adapted industrial UL fire rated (UL94 HF-1) insulation foam with mould resistant feature. The material guarantees safety compliance of the cooling unit with international building standards. Mould resistant foil helps to prevent the spread of mould and mildew due to humidity from the supply air increasing overall air quality.



Heat Insulator Material

G4/MERV8 Air filter, Delta RowCool employed industrial grade G4/MERV8 for high efficiency air flow and maximum filtration with Aluminum frame for increased strength and reduced vibration.



High quality powder coating, the body and structure made of galvanized steel has been additionally surfaced by industrial grade powder coating ensuring protection all surface from rust over its life time, RAL Jet Black or RAL7035 Light Grey

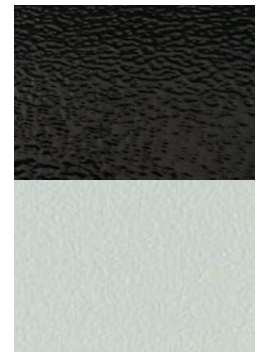

FULL PROTECTION, All electronic and electrical components are protected by dedicated miniature circuit breakers for increased safety, flexibility and reliability during facility commissioning, operation and maintenance.



MATCHED CONDENSERS, rated at 45 degree C ambient operation in accordance to for compliance to Data Center design standards. Custom designs available for demanding applications.



HSF08A, 12A

HSF18A

HSF24A, 32A, 38A

HSF52A

Technical specification

Outdoor ambient temperature 35 °C

Indoor Unit

Indoor Model			HCH-0530R	HCH-0730R	HCH-1230R	HCH-1730R	HCH-2030R	HCH-2530R	HCH-3030R	HCH-4060R	HCH-5060R
Power	Input Voltage	V	220-240 , 1P 2W+G				380-415V, 3P, 4W+G				
	Input Frequency	Hz	50 (Optional Inverter for 60Hz)								
	Number of source		1 input source (Optional ATS for dual source)								
FLA	Full-load Ampere	A	38.4	42.4	22	32.1	31.8	33	44.8	47.9	58.3
Capacity	Cooling Capacity	kW	5.6	7.6	12.8	17.6	21.2	25.1	31.1	40.9	51.2
	Sensible heat ratio	%	100								
Refrigerant	Type		R-410A								
	Charge	kg	4	4	4.5	7	7	8	9.5	15	17.5
Fan	Type		EC Fan (Centrifugal)								
	Quantity	n.	3			6					
	Air Volume	m ³ /h	2,280	2,250	2,400	4,500	4,920	5,000	5,800	8,000	10,000
Controller	Setting Temperature	°C	18 to 27								
	Temperature Accuracy	%	+/- 1°C								
	Setting Humidity	% RH	20 to 80								
	Control Type		PID control								
Filter	Control Scheme		Supply Air Control / Return Air Control								
	Type		G4								
Reheat (Option)	Quantity		2								
	Type		Electric Heater (PTC)								
Humidifier (Option)	Capacity	kW	3				6				
	Type	Type	Electrode Boiler								
Interface	Capacity	kg/h	1.5						3		
	User Interface		7" touch screen								
Audible Noise	Communication		MODBUS RS-485, Optional SNMP								
	Sound level at 1 m	dB	64	58	62.5	60	62	63.5	66.5	71.5	79
Dimension	Width	mm	300	300	300	300	300	300	300	600	600
	Dept	mm	1100	1100	1100	1100	1100	1100	1100	1100	1100
	Height	mm	2000	2000	2000	2000	2000	2000	2000	2000	2000
	Weight	kg	210	213	233	253	258	260	320	360	420
Piping size	Refrigerant (liquid/gas)	mm	10/12	10/12	12/16	12/16	12/19	12/19	12/22	16/22	16/22
	Drainage	mm	20	20	20	20	20	20	20	20	20
Water Drainage	Water In		3/4" G	3/4" G	3/4" G	3/4" G	3/4" G	3/4" G	3/4" G	3/4" G	3/4" G
	Standard		Gravity Drainage								
	Optional		Water Pump Drainage								

Outdoor Unit

Outdoor Model			HSF-08A	HSF-12A	HSF-18A	HSF-24A	HSF-32A	HSF-38A	HSF-42A	HSF-52A	HSF-62A
Power	Input Voltage	V	220-240 , 1P 2W+G				380-415V, 3P 4W+G				
	Input Frequency	Hz	50Hz								
FLA-A	Full-load Ampere	A	1.5	1.5	3	2	2	2.8	2.8	4	4
Dimension	Width (L)	mm	800	800	800	1407	1407	1407	1607	1607	1907
	Dept (H)	mm	790	790	1240	990	990	990	1273	1273	1273
	Height (W)	mm	420	420	455	689	689	695	695	695	689
	Feet Height	mm	-	-	-	450	450	450	450	450	450
Audible Noise	Weight	kg	28	40	67	105	110	120	130	150	160
	At 1m distance	dB	44	45	44	55	54	45	66	66	64
Fan	Type		EC Fan (Axial)				Inverter Fan (Axial)				
	Quantity	n.	1	1	2	1	1	1	1	1	2
	Air Volume	m ³ /h	4,200	4,200	8,400	13,600	8,150	15,800	14,000	14,000	25,600
Piping size	Refrigerant (liquid/gas)	mm	10/12	10/12	10/16	16/22	16/22	16/22	16/22	22/28	22/28

Notes :

- Capacity based on 37°C/24%RH return air conditions, and 35°C ambient temperature.
- The standard ESP 20Pa. Higher application shall refer to technical department for confirmation.
- Full load current parameters of the indoor unit includes the outdoor unit of full load current.
- Standard air-cooled outdoor unit operating temperature range-15°C above, optional operating temperature range of the components-35°C with low temperature kit.
- Rights reserved to change parameters without prior notification.

The power behind competitiveness



Technical specification

Outdoor ambient temperature 40 °C

Indoor Unit

Indoor Model			HCH-0530R	HCH-0730R	HCH-1230R	HCH-1730R	HCH-2030R	HCH-2530R	HCH-3030R	HCH-4060R	HCH-5060R	
Power	Input Voltage	V	220-240 , 1P 2W+G				380-415V, 3P, 4W+G					
	Input Frequency	Hz	50 (Optional Inverter for 60Hz)									
	Number of source		1 input source (Optional ATS for dual source)									
FLA	Full-load Ampare	A	38.4	42.4	22	32.1	31.8	33	44.8	47.9	58.3	
Capacity	Cooling Capacity	kW	5.6	7.6	12.8	17.6	21.2	25.1	31.1	40.9	51.2	
	Sensible heat ratio	%	100									
Refrigerant	Type		R-410A									
	Charge	kg	4	4	4.5	7	7	8	9.5	15	17.5	
Fan	Type		EC Fan (Centrifugal)									
	Quantity	n.	3			6			2		2	
	Air Volume	m ³ /h	2,280	2,250	2,400	4,500	4,920	5,000	5,800	8,000	10000	
Controller	Setting Temperature	°C	18 to 27									
	Temperature Accuracy	%	±/- 1°C									
	Setting Humidity	% RH	20 to 80									
	Control Type		PID control									
	Control Scheme		Supply Air Control / Return Air Control									
Filter	Type		G4									
	Quantity		2									
Reheat (Option)	Type		Electric Heater (PTC)									
	Capacity	kW	3			6						
Humidifier (Option)	Type	Type	Electrode Boiler									
	Capacity	kg/h	1.5						3			
Interface	User Interface		7" touch screen									
	Communication		MODBUS RS-485, Optional SNMP									
Audible Noise	Sound level at 1 m	dB	64	58	62.5	60	62	63.5	66.5	71.5	79	
Dimension	Width	mm	300	300	300	300	300	300	300	600	600	
	Dept	mm	1100	1100	1100	1100	1100	1100	1100	1100	1100	
	Height	mm	2000	2000	2000	2000	2000	2000	2000	2000	2000	
	Weight	kg	210	213	233	253	258	260	320	360	420	
Piping size	Refrigerant (liquid/gas)	mm	10/12	10/12	12/16	12/16	12/19	12/19	12/22	16/22	16/22	
	Drainage	mm	20	20	20	20	20	20	20	20	20	
	Water In		3/4" G	3/4" G	3/4" G	3/4" G	3/4" G	3/4" G	3/4" G	3/4" G	3/4" G	
Water Drainage	Standard		Gravity Drainage									
	Optional		Water Pump Drainage									

Outdoor Unit

Outdoor Model			HSF-08A	HSF-12A	HSF-18A	HSF-24A	HSF-32A	HSF-38A	HSF-42A	HSF-52A	HSF-62A	
Power	Input Voltage	V	220-240 , 1P 2W+G				380-415V, 3P 4W+G					
	Input Frequency	Hz	50Hz									
FLA-A	Full-load Ampare	A	1.5	1.5	3	2	2.8	2.8	2.8	4	4	
Dimension	Width (L)	mm	800	800	800	1407	1407	1407	1607	1607	1907	
	Dept (H)	mm	790	790	1240	990	990	990	1273	1273	1273	
	Height (W)	mm	420	420	420	689	689	695	695	695	689	
	Feet Height	mm	-	-	-	450	450	450	450	450	450	
	Weight	kg	28	40	67	105	110	120	130	150	160	
Audible Noise	At 1m distance	dB	44	45	44	55	54	45	66	66	64	
Fan	Type		EC Fan (Axial)				Inverter Fan (Axial)					
	Quantity	n.	1	1	2	1	1	1	1	1	2	
	Air Volume	m ³ /h	4,200	4,200	8,400	13,600	8150	15,800	14,000	14,000	25,600	
Piping size	Refrigerant (liquid/gas)	mm	10/12	10/12	10/16	16/22	16/22	16/22	16/22	22/28	22/28	

Notes :

- Capacity based on 37°C/24%RH return air conditions, and 40°C ambient temperature.
- The standard ESP 20Pa. Higher application shall refer to technical department for confirmation.
- Full load current parameters of the indoor unit includes the outdoor unit of full load current.
- Standard air-cooled outdoor unit operating temperature range -15°C above, optional operating temperature range of the components -35°C with low temperature kit.
- Rights reserved to change parameters without prior notification.

The power behind competitiveness



Technical specification

Outdoor ambient temperature 45 °C

Indoor Unit

Indoor Model			HCH-0530R	HCH-0730R	HCH-1230R	HCH-1730R	HCH-2030R	HCH-2530R	HCH-3030R	HCH-4060R	HCH-5060R	
Power	Input Voltage	V	220-240 , 1P 2W+G				380-415V, 3P, 4W+G					
	Input Frequency	Hz	50 (Optional Inverter for 60Hz)									
	Number of source		1 input source (Optional ATS for dual source)									
FLA	Full-load Ampere	A	38.4	42.4	22	32.1	31.8	33	44.8	47.9	58.3	
Capacity	Cooling Capacity	kW	5.6	7.6	12.8	17.6	21.2	25.1	31.1	40.9	51.2	
	Sensible heat ratio	%	100									
Refrigerant	Type		R-410A									
	Charge	kg	4	4	4.5	7	7	8	9.5	15	17.5	
Fan	Type		EC Fan (Centrifugal)									
	Quantity	n.	3			6			2		2	
	Air Volume	m ³ /h	2,280	2,250	2,400	4,500	4,920	5,000	5,800	8,000	10,000	
Controller	Setting Temperature	°C	18 to 27									
	Temperature Accuracy	%	+/- 1°C									
	Setting Humidity	% RH	20 to 80									
	Control Type		PID control									
Filter	Type		G4									
	Quantity		2									
Reheat (Option)	Type		Electric Heater (PTC)									
	Capacity	kW	3			6						
Humidifier (Option)	Type	Type	Electrode Boiler									
	Capacity	kg/h	1.5						3			
Interface	User Interface		7" touch screen									
	Communication		MODBUS RS-485, Optional SNMP									
Audible Noise	Sound level at 1m	dB	64	58	62.5	60	62	63.5	66.5	71.5	79	
Dimension	Width	mm	300	300	300	300	300	300	300	600	600	
	Dept	mm	1100	1100	1100	1100	1100	1100	1100	1100	1100	
	Height	mm	2000	2000	2000	2000	2000	2000	2000	2000	2000	
	Weight	kg	210	213	233	253	258	260	320	360	420	
Piping size	Refrigerant (liquid/gas)	mm	10/12	10/12	12/16	12/16	12/19	12/19	12/22	16/22	16/22	
	Drainage	mm	20	20	20	20	20	20	20	20	20	
	Water In		3/4" G	3/4" G	3/4" G	3/4" G	3/4" G	3/4" G	3/4" G	3/4" G	3/4" G	
Water Drainage	Standard		Gravity Drainage									
	Optional		Water Pump Drainage									

Outdoor Unit

Outdoor Model			HSF-08A	HSF-12A	HSF-18A	HSF-24A	HSF-38A	HSF-42A	HSF-52A	HSF-62A	HSF-70A	
Power	Input Voltage	V	220-240 , 1P 2W+G				380-415V, 3P 4W+G					
	Input Frequency	Hz	50Hz									
FLA-A	Full-load Ampere	A	1.5	1.5	3	2	2.8	2.8	4	4	4	
Dimension	Width (L)	mm	800	800	800	1407	1407	1607	1607	1907	1907	
	Dept (H)	mm	790	790	1240	990	990	1273	1273	1273	1273	
	Height (W)	mm	420	420	455	689	695	695	695	689	689	
	Feet Height	mm	-	-	-	450	450	450	450	450	450	
Aubible Noise	Weight	kg	28	40	67	105	120	130	150	160	160	
	At 1m distance	dB	44	45	44	55	45	66	66	64	64	
Fan	Type		EC Fan (Axial)				Inverter Fan (Axial)					
	Quantity	n.	1	1	2	1	1	1	1	2	2	
	Air Volume	m ³ /h	4,200	4,200	8,400	13,600	15,800	14,000	14,000	25,600	25,600	
Piping size	Refrigerant (liquid/gas)	mm	10/12	10/12	10/16	16/22	16/22	16/22	22/28	22/28	22/28	

Notes :

- Capacity based on 37°C/24%RH return air conditions, and 45°C ambient temperature.
- The standard ESP 20Pa. Higher application shall refer to technical department for confirmation.
- Full load current parameters of the indoor unit includes the outdoor unit of full load current.
- Standard air-cooled outdoor unit operating temperature range -15°C above, optional operating temperature range of the components -35°C with low temperature kit.
- Rights reserved to change parameters without prior notification.

The power behind competitiveness



Delta Electronics (Thailand) PCL
909 Moo 4, E.P.Z., Bangpoo Industrial Estate
Phraksa, Muang, Samutprakarn 10280,
THAILAND
TEL: +66-2-709-2800
ups.thailand@deltaww.com

Delta Green Industrial (Thailand) Co., Ltd.
111 Moo 9, Wellgrow Industrial Estate
Bangwua, Bangpakong, Chachoengsao 24180,
THAILAND
TEL: +66-2-709-2800
ups.thailand@deltaww.com

Delta Energy Systems (Singapore) Pte Ltd.
4 Kaki Bukit Ave 1, #05-04,
SINGAPORE 417939
TEL: +65-6747-5155
ups.singapore@deltaww.com

Delta Energy Systems Australia Pty Ltd.
20-21/45 Normanby Road Notting Hill,
VIC 3168, Australia
TEL: +61-3-9543-3720
ups.australia@deltaww.com