

The power behind competitiveness

## Delta UPS Amplon Family

N Gen3 Series, Single Phase  
1/ 2/ 3 kVA

User Manual

## SAVE THIS MANUAL

This manual contains important instructions and warnings that you should follow during the installation, operation, storage and maintenance of this product. Failure to heed these instructions and warnings will void the warranty.

Copyright © 2023 by Delta Electronics Inc. All Rights Reserved. All rights of this User Manual (“Manual”), including but not limited to the contents, information, and figures are solely owned and reserved by Delta Electronics Inc. (“Delta”). The Manual can only be applied to the operation or the use of this product. Any disposition, duplication, dissemination, reproduction, modification, translation, extraction, or usage of this Manual in whole or in part is prohibited without the prior written permission of Delta. Given that Delta will continuously improve and develop the product, changes may be made to the information in this Manual at any time without obligation to notify any person of such revision or changes. Delta will make all possible efforts to secure the accuracy and the integrity of this Manual. Delta disclaims any kinds or forms of warranty, guarantee, or undertaking, either expressly or implicitly, including but not limited to the completeness, faultlessness, accuracy, non-infringement, merchantability or fitness for a particular purpose of the Manual.

# Table of Contents

<b>Chapter 1 : Important Safety Warnings</b>	<b>1</b>
1.1 Transportation	1
1.2 Preparation	1
1.3 Installation	1
1.4 Operation	2
1.5 Maintenance, Service and Faults	2
1.6 Packing List	3
<b>Chapter 2 : Installation and Setup</b>	<b>4</b>
2.1 Rear Panel View	4
2.2 Operating Principle	6
2.3 Setup the UPS	6
2.4 Battery Replacement	10
<b>Chapter 3 : Operation</b>	<b>11</b>
3.1 Button Operation	11
3.2 LCD Panel	12
3.3 Audible Alarm	14
3.4 LCD Display Wordings Index	15
3.5 UPS Setting	16
3.6 Operating Mode Description	21
3.7 Faults Reference Code	22
3.8 Warning Indicator	23
<b>Chapter 4 : Optional Accessories</b>	<b>24</b>
<b>Chapter 5 : Troubleshooting</b>	<b>25</b>
<b>Chapter 6 : Storage and Maintenance</b>	<b>27</b>
<b>Appendix 1 : Technical Specifications</b>	<b>28</b>
<b>Appendix 2 : Warranty</b>	<b>31</b>

# Chapter 1: Important Safety Warnings

Please comply with all warnings and operating instructions in this manual strictly. Save this manual properly and read carefully the following instructions before installing the unit. Do not operate this unit before reading through all safety information and operating instructions carefully.

## 1.1 Transportation

- Please transport the UPS system only in the original package to protect against shock and impact.

## 1.2 Preparation

- Install the UPS in a well-ventilated indoor area, away from excess moisture, heat, dust, flammable gas or explosives. To avoid fire accidents and electric shock, the indoor area must be free of conductive contaminants. For the temperature and humidity specifications, please refer to **Appendix 1: Technical Specifications**.
- Do not block ventilation holes in the UPS housing.

## 1.3 Installation

- Do not connect appliances or devices which would overload the UPS system (e.g. laser printers) to the UPS output sockets.
- It is not recommended to connect the UPS with following type of loads. For the load suitability please contact Delta customer service before purchasing.
  1. Regenerative loads (e.g. CNC machine and lifts)
  2. Asymmetrical loads (e.g. fans with half-bridge drivers and laser printers)
- Place cables in such a way that no one can step on or trip over them.
- Do not connect domestic appliances such as hair dryers to the UPS output sockets.
- The UPS can be operated by any individuals with no previous experience.
- Connect the UPS system only to an earthed shockproof outlet which must be easily accessible and close to the UPS system.
- Please use only VDE-tested, CE-marked mains cable (e.g. the mains cable of your computer) to connect the UPS system to the building wiring outlet (shockproof outlet).
- Please use only VDE-tested, CE-marked power cables to connect the loads to the UPS system.

- When installing the equipment, please ensure that the sum of the leakage current of the UPS and the connected devices does not exceed 3.5mA.

### 1.4 Operation

- Do not disconnect the mains on the UPS system or the building wiring outlet (shockproof socket outlet) during operations since this would cancel the protective earthing of the UPS system and of all connected loads.
- The UPS system features its own, internal current source (batteries). The UPS output sockets or output terminals block may be electrically live even if the UPS system is not connected to the building wiring outlet.
- In order to fully disconnect the UPS system, first press the OFF/ ENTER button to disconnect the mains.
- Before usage, you must allow the UPS to adjust to room temperature for at least one hour to ensure that there is no moisture condensing inside the UPS.
- Do not pour and splash any liquid on the UPS. Do not insert any object into the UPS's slits and openings. Do not put beverages on or around the UPS.

### 1.5 Maintenance, Service and Faults

- The UPS system operates with hazardous voltages. Repairs may be carried out only by qualified maintenance personnel.



#### **WARNING:**

- Risk of electric shock. Even after the unit is disconnected from the mains (building wiring outlet), components inside the UPS system are still connected to the battery and electrically live and dangerous.
- Before carrying out any kind of service and/ or maintenance, disconnect the batteries and verify that no current is present and no hazardous voltage exists in the terminals of high capability capacitor such as BUS-capacitors.
  - Only qualified personnel can perform battery replacement. Unauthorized personnel shall be kept away from the batteries.



#### **WARNING:**

- Risk of electric shock. The battery circuit is not isolated from the input voltage. Hazardous voltages may occur between the battery terminals and the ground. Before touching, please verify that no voltage is present!
- The following precautions should be observed before battery replacement:
    - Remove watches, rings, or any other metal objects.
    - Use tools with insulated handles.

- Wear rubber gloves and boots.
  - Do not lay tools or metal parts on the top of batteries.
  - Disconnect charging source prior to connecting or disconnecting the battery input terminals.
  - Remove every battery grounding during installation and maintenance to reduce the likelihood of electric shock. If any part of the batteries is grounded, please remove the grounding connection.
- When changing batteries, install the same number and same type of batteries.
  - Do not dispose of batteries in a fire. The batteries may explode.
  - Do not open or destroy batteries. The released electrolyte is harmful to skin and eyes and may be toxic.
  - Please replace the fuse only with the same type and amperage in order to avoid fire hazards.
  - Do not dismantle the UPS system.

## 1.6 Packing List

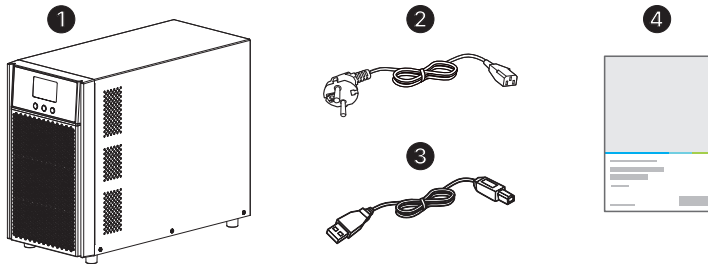

No.	Item	Q'ty
①	UPS* <sup>1</sup>	1 PC
②	Input cable* <sup>2</sup>	1 PC
③	USB cable	1 PC
④	User manual	1 PC



### NOTE:

\*<sup>1</sup> For more model information, please refer to **Appendix I: Technical Specifications**.

\*<sup>2</sup> This item may differ according to different models, please refer to **Table 1**.

## Chapter 2: Installation and Setup



**NOTE:**

Before installation, please inspect the unit. Be sure that nothing inside the package is damaged. Please keep the original package in a safe place for future use.

### 2.1 Rear Panel View

- Standard Runtime Model

UPA102N2NX0B035

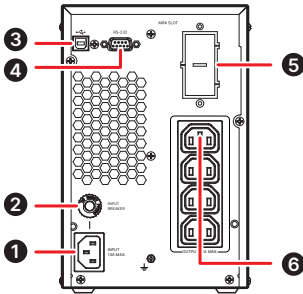

UPA102N2NX0B0BA

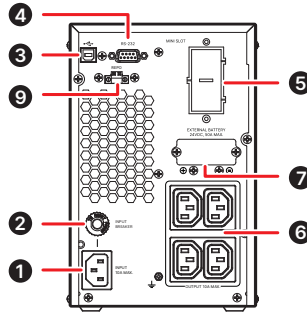

UPA302N2NX0B035

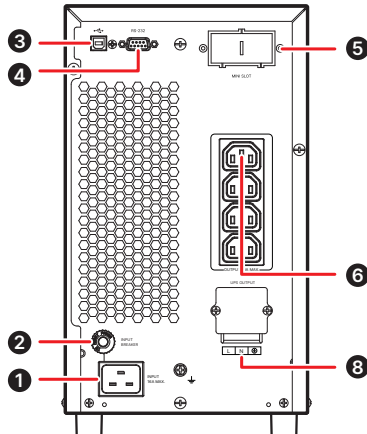

UPA202N2NX0B035/  
UPA202N2NX0B0BB

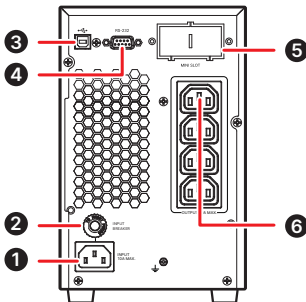

UPA102N2NX0B0B1

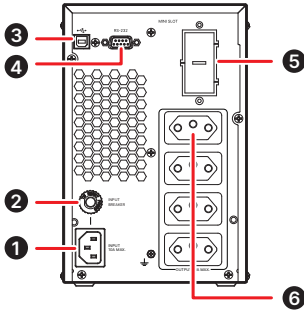

UPA202N2NX0B0B1

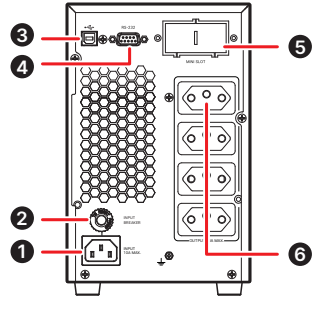

UPA302N2NX0B0B1

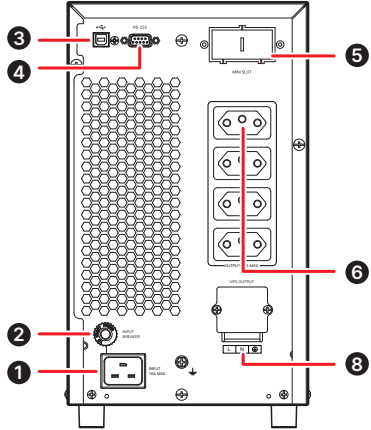

No.	Item
①	AC input
②	Input circuit breaker
③	USB port
④	RS-232 port
⑤	Mini slot



No.	Item
⑥	Output socket
⑦	External battery connector
⑧	Output terminal
⑨	REPO Port

## 2.2 Operating Principle

The operating principle of the UPS is shown as below:

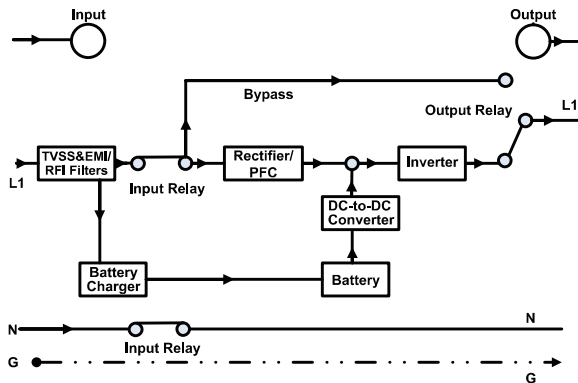

## 2.3 Setup the UPS

### Step 1: Connection of battery wires (optional)



#### NOTE:

Only applicable to models with P/N ending with 0BA.

If the extended runtime function is to be adopted, please connect external batteries as shown below.

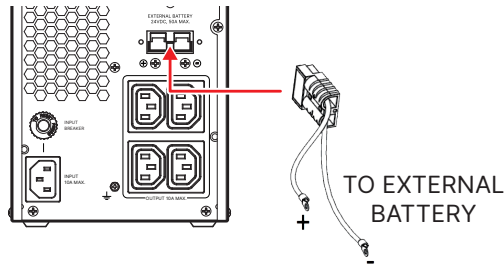

Please refer to the figure below to secure the battery cable to the terminal with the suitable screws and nuts.

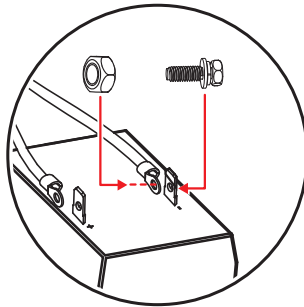

## Step 2: UPS input connection

Plug the UPS into a two-pole, three-wire, grounded receptacle only. Avoid using extension cords.

- The power cord will be delivered with the UPS. For the type of power cord, please refer to the table below.

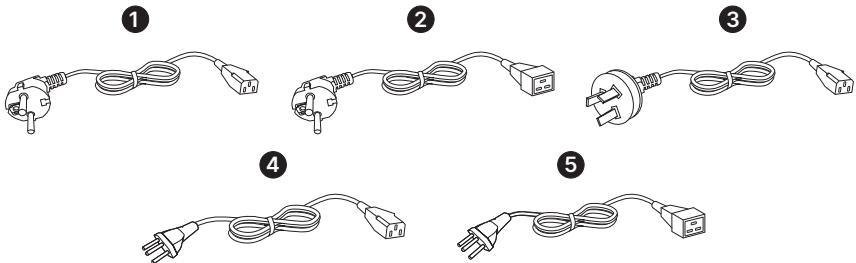

Table 1: Power Cords for Different UPS Models

UPS			Type of Power Cord
①	UPA102N2NX0B035	1kVA	Plug IEC C14
	UPA202N2NX0B035	2kVA	Plug IEC C14
②	UPA302N2NX0B035	3kVA	Plug IEC C20
①	UPA102N2NX0B0BA	1kVA	Plug IEC C14
③	UPA202N2NX0B0BB	2kVA	Plug 10A Australia
④	UPA102N2NX0B0B1	1kVA	Plug 10A Brazil
	UPA202N2NX0B0B1	2kVA	Plug 10A Brazil
⑤	UPA302N2NX0B0B1	3kVA	Plug 16A Brazil

### Step 3: UPS output connection

- For output sockets, simply connect devices to the outlets.
- For output terminals, please follow the steps below for the wiring configuration:
  1. Remove the small cover of the terminal block.
  2. We suggest using AWG 12~10 or 3.3mm<sup>2</sup>~5.3mm<sup>2</sup> power cords for 3kVA. Please install a circuit breaker (40A) between the mains and the AC input of the 3kVA UPS for safe operation.
  3. Upon the completion of the wiring configuration, please check whether the wires are securely affixed.
  4. Install the small cover back to the rear panel.

#### Step 4: Communication connection

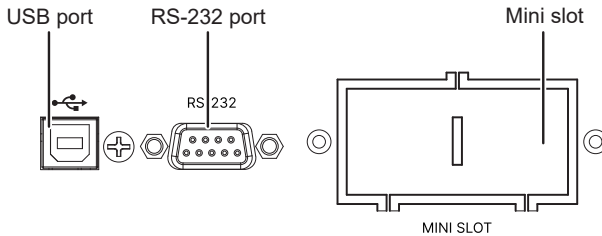

To allow shutdown/ start-up and status monitoring for unattended UPS, connect one end of the communication cable to the USB/ RS-232 port and the other to the communication port of your PC. With the monitoring software installed, you can schedule UPS shutdown/ start-up and monitor UPS status via your PC.

The UPS is equipped with Mini slot perfect for Delta Mini SNMP, Relay I/O, or MODBUS cards (optional). After the Mini SNMP is installed in the UPS, advanced communication and monitoring functions will be available.



#### NOTE:

1. The USB port and the RS-232 port cannot work at the same time.
2. If you choose to use the USB port instead of the RS-232 port, please install the USB driver software in your computer after connecting your computer to the UPS's USB port. The software can be downloaded from <http://datacenter-softwarecenter.deltaww.com>

#### Step 5: Disabling/ enabling of REPO function



#### NOTE:

Only applicable to models with P/N ending with OBA.

Keep pin 1 and pin 2 closed for UPS normal operation. To activate REPO function, cut the wire between pin 1 and pin 2.

The REPO port can be connected to an external switch. After the external switch is turned to the "OPEN" position, the UPS will switch off the inverter immediately and cut off the UPS output without transferring to the bypass mode.



**NOTE:**

The REPO port can also be used for ROO application, which allows you remotely turn on/ off the inverter. If you need detailed ROO information or ROO setup service, please contact your local dealer or customer service.

**Step 6: Turn-on of the UPS**

Press the ON/ MUTE button on the front panel for two seconds to power on the UPS.



**NOTE:**

UPS will be available for full runtime capability after the initial five-hour charging.

**Step 7: Installation of software**

For optimal system protection, install UPS monitoring software to fully configure UPS. Please download the software from <http://datacenter-softwarecenter.deltaww.com>

## 2.4 Battery Replacement



**WARNING:**

Consider all warnings, cautions, and notes before replacing batteries.



**NOTE:**

Upon battery disconnection, equipment is not protected from power outages.

# Chapter 3 : Operation

## 3.1 Button Operation

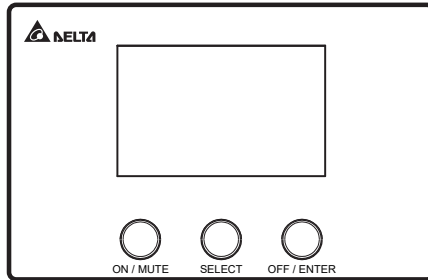





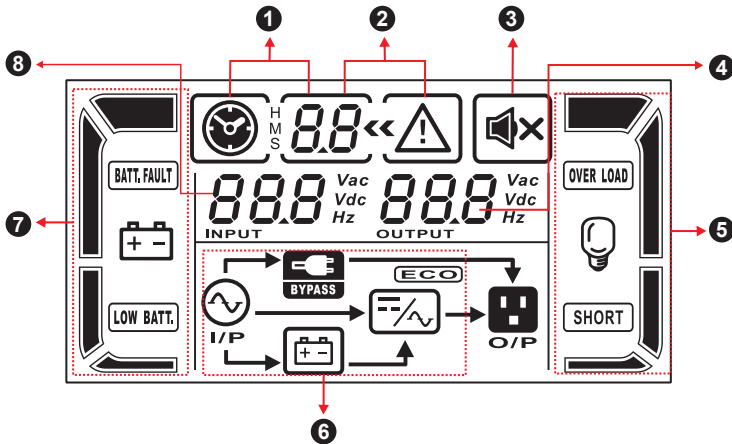

Button	Function
<p><b>ON/ MUTE Button</b></p>	<ul style="list-style-type: none"> <li>• Turn on the UPS: Press and hold the ON/ MUTE button for at least 2 seconds to turn on the UPS.</li> <li>• Mute the alarm: When the UPS is in battery mode, press and hold this button for at least 5 seconds to disable or enable the alarm system. The ON/ MUTE button is not applicable when warnings or errors occur.</li> <li>• Up key: Press this button to display the previous selection in UPS setting mode.</li> <li>• Switch to UPS self-test mode: Press and hold this button for 5 seconds to start UPS self-testing while in AC mode, ECO mode, or converter mode.</li> </ul>
<p><b>OFF/ ENTER Button</b></p>	<ul style="list-style-type: none"> <li>• Turn off the UPS: Press and hold this button for at least 2 seconds to turn off the UPS. The UPS will switch to either standby mode or bypass mode according to your setting of bypass function. If you enable the bypass function, the UPS will transfer to bypass mode; if you disable the bypass function, the UPS will transfer to standby mode without any output. Please refer to <b>3.5 UPS Setting- 06: Bypass enable/ disable when the UPS is off.</b></li> </ul>









Button	Function
<b>OFF/ ENTER Button</b>	<ul style="list-style-type: none"> <li>Confirm selection key: Press this button to confirm selection in setting mode.</li> </ul>
<b>SELECT Button</b>	<ul style="list-style-type: none"> <li>Switch LCD message: Press this button to change the LCD message for input voltage, input frequency, battery voltage, output voltage and output frequency. It will return to default display when pausing for 10 seconds.</li> <li>Setting mode: Press and hold this button for 5 seconds to enter setting mode when the UPS is in standby mode or bypass mode.</li> <li>Down key: Press this button to display the next selection in setting mode.</li> </ul>
<b>ON/ MUTE + SELECT Buttons</b>	<ul style="list-style-type: none"> <li>Switch to bypass mode: When the main power is normal, press the ON/ MUTE and SELECT buttons simultaneously for 5 seconds. Then the UPS will enter bypass mode. This action will be ineffective when the input voltage is out of acceptable range.</li> </ul>

### 3.2 LCD Panel



Display	Function
<b>① Remaining backup time information</b>	
	Indicates the remaining backup time in a pie chart.
H M S <b>8.8</b>	Indicates the remaining backup time in numbers. H: hour, M: minute, S: second
<b>② Fault information</b>	
	Indicates that the warning and fault occurs.
<b>8.8</b>	Indicates the warning and fault codes, and the codes are listed in details in <b>3.7 fault reference code</b> .
<b>③ Mute operation</b>	
	Indicates that the UPS alarm is disabled.
<b>④ Output &amp; Battery voltage information</b>	
<b>888</b> Vac Vdc Hz OUTPUT	Indicates the output voltage, frequency or battery voltage. Vac: output voltage, Vdc: battery voltage, Hz: frequency
<b>⑤ Load information</b>	
	Indicates the load level by 0-25%, 26-50%, 51-75%, and 76-100%.
<b>OVER LOAD</b>	Indicates overload.
<b>SHORT</b>	Indicates the load or the UPS output is short circuit.
<b>⑥ Mode operation information</b>	
	Indicates the UPS connects to the mains.
	Indicates the battery is working.



Display	Function
	Indicates the bypass circuit is working.
	Indicates the ECO mode is enabled.
	Indicates the inverter circuit is working.
	Indicates the output is working.
<b>7 Battery information</b>	
	Indicates the battery level by 0-25%, 26-50%, 51-75%, and 76-100%.
	Indicates the battery is fault.
	Indicates low battery level and low battery voltage.
<b>8 Input &amp; Battery voltage information</b>	
	Indicates the input voltage or frequency or battery voltage. Vac: Input voltage, Vdc: battery voltage, Hz: input frequency

### 3.3 Audible Alarm

Condition	Alarm
Battery Mode	Sounding every 4 seconds
Low Battery	Sounding every second
Overload	Sounding twice every second
Fault	Continuously sounding
Bypass Mode	Sounding every 10 seconds

### 3.4 LCD Display Wordings Index

Abbreviation	Display Content	Meaning
ENA	<i>ENR</i>	Enable
DIS	<i>DIS</i>	Disable
ESC	<i>ESC</i>	Escape
HLS	<i>HLS</i>	High loss
LLS	<i>LLS</i>	Low loss
BAT	<i>BAT</i>	Battery
CF	<i>CF</i>	Converter
TP	<i>TP</i>	Temperature
CH	<i>CH</i>	Charger
FU	<i>FU</i>	Bypass frequency unstable
EE	<i>EE</i>	EEPROM error

### 3.5 UPS Setting

There are three parameters to set up the UPS.

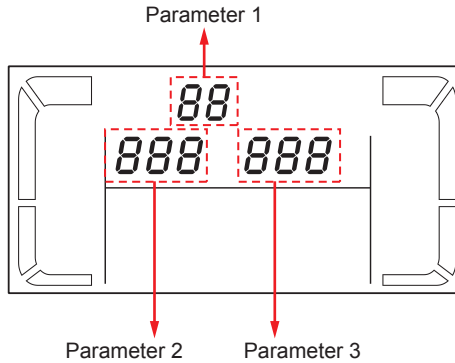

**Parameter 1:** It is for function selection. Refer to the table below.

**Parameter 2** and **Parameter 3** are the setting options or values for each program.

#### 01: Output voltage setting

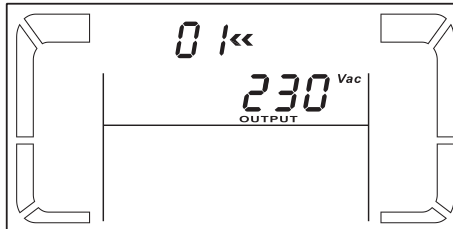

**Parameter 3:** Output voltage

You may choose the following output voltage:

- 200:** presents output voltage is 200Vac
- 208:** presents output voltage is 208Vac
- 220:** presents output voltage is 220Vac
- 230:** presents output voltage is 230Vac (Default)
- 240:** presents output voltage is 240Vac

## 02: Frequency converter enable/ disable

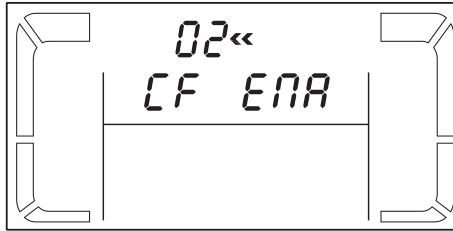

**Parameter 2 & 3:** Enable or disable converter mode. You may choose the following two options.

**CF ENA:** converter mode enable

**CF DIS:** converter mode disable (Default)

## 03: Output frequency setting

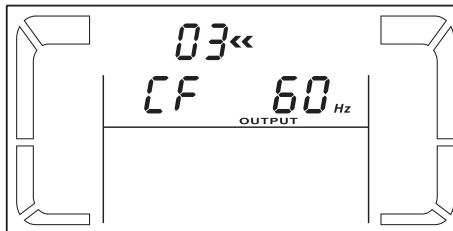

**Parameter 2 & 3:** Output frequency setting.

If the battery mode is enabled, you may choose the following initial frequency.

**BAT 50:** presents output frequency 50Hz

**BAT 60:** presents output frequency 60Hz

If the converter mode is enabled, you may choose the following output frequency.

**CF 50:** presents output frequency 50Hz

**CF 60:** presents output frequency 60Hz

## 04: ECO enable/ disable

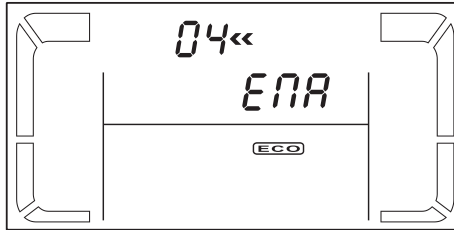

**Parameter 3:** Enable or disable ECO function. You may choose the following two options.

**ENA:** ECO mode enable

**DIS:** ECO mode disable (Default)

## 05: ECO voltage range setting

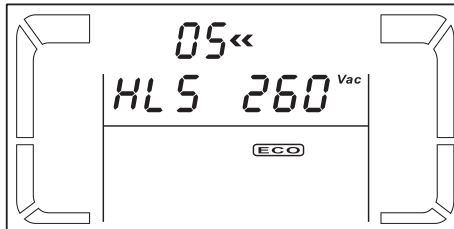

**Parameter 2 & 3:** Set an acceptable high voltage point and a low voltage point for ECO mode by pressing the Down key or Up key.

**HLS:** High loss voltage in ECO mode in parameter 2.

The setting range in parameter 3 is from +7V to +24V of the nominal voltage. (Default: +12V)

**LLS:** Low loss voltage in ECO mode in parameter 2.

The setting range in parameter 3 is from -7V to -24V of the nominal voltage. (Default: -12V)

## 06: Bypass enable/ disable when the UPS is off

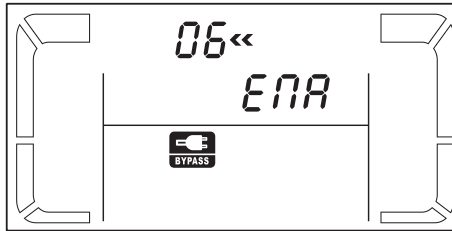

**Parameter 3:** Enable or disable bypass function. You may choose the following two options.

**ENA:** Bypass enable

**DIS:** Bypass disable (Default)

## 07: Bypass voltage range setting

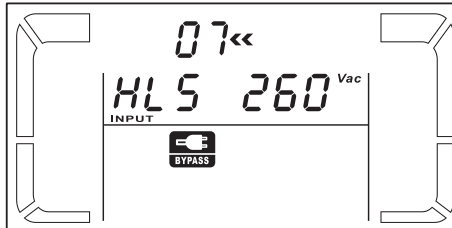

**Parameter 2 & 3:** Set the acceptable high voltage point and acceptable low voltage point for bypass mode by pressing the Down key or Up key.

**HLS:** Bypass high voltage point

230-264: setting the high voltage point in parameter 3 from 230Vac to 264Vac. (Default: 264Vac)

**LLS:** Bypass low voltage point

170-220: setting the low voltage point in parameter 3 from 170Vac to 220Vac. (Default: 170Vac)

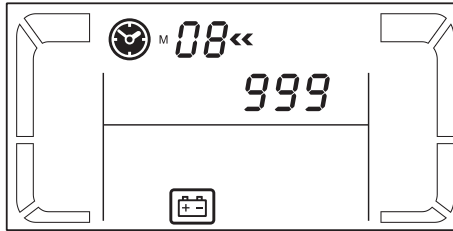
**08: Discharging time limitation**

**Parameter 3:** Set the discharging time limitation in battery mode for general outlets.

**0 ~ 999:** Set up the discharging time limitation in minutes from 0 ~ 999 for general outlets in battery mode.

**0:** When setting as "0", the discharging time will be only 10 seconds.

**999:** When setting as "999", the discharging time limitation will be disabled (Default).

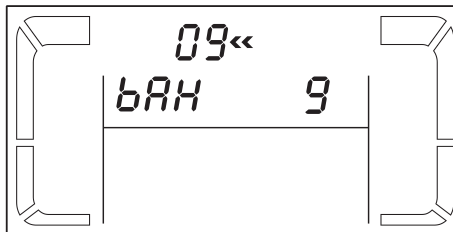
**09: Total battery AH**

**Parameter 3:** Set up total battery AH value of the UPS. (unit: AH)

**7-999:** Set up the total battery capacity from 7 to 999. Please set up this figure if external battery pack is connected.

If the UPS is standard runtime model, the default setting is 9AH.

## 00: Exit Setting

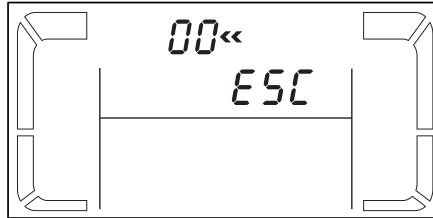

Exit the setting mode.

## 3.6 Operating Mode Description

- **Online Mode**

When the input voltage is within the acceptable range, the UPS will provide pure sine wave and stable AC power to output. The UPS will also charge the battery in online mode.

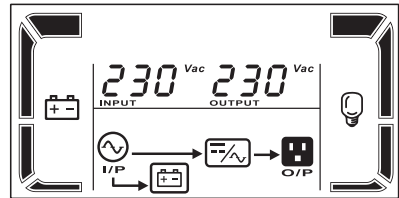

- **ECO Mode**

Energy saving mode:

When the input voltage is within voltage regulation range, the UPS will run in bypass mode to supply power to output for energy saving.

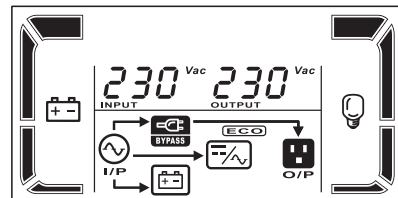

- **Frequency Converter Mode**

When the input frequency is between 40 Hz and 70 Hz, the UPS can be set at a constant output frequency, 50 Hz or 60 Hz. The UPS will still charge batteries under this mode.

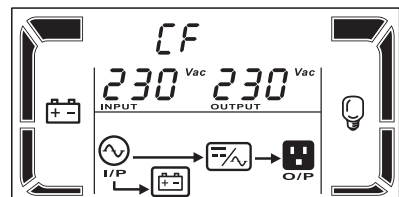



- **Battery Mode**

When the input voltage is beyond the acceptable range or a power failure has occurred, the UPS will backup power from batteries and an alarm will be sounding every 4 seconds.

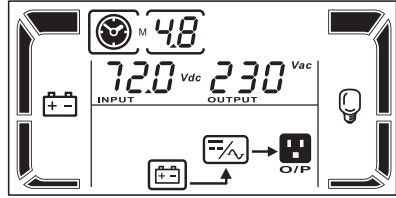

- **Bypass Mode**

When the input voltage is within the acceptable range but the UPS is overloaded, the UPS will enter bypass mode or bypass mode can be set via the front panel. The alarm is sounding every 10 seconds.

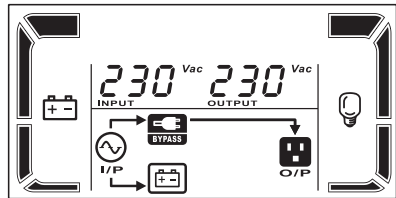



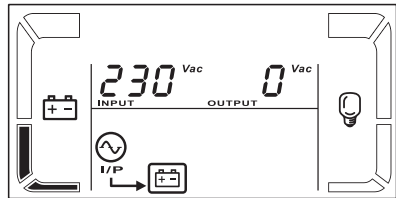

- **Standby Mode**

The UPS is powered off and there is no output, but the batteries can still be charged.













### 3.7 Faults Reference Code

Fault Event	Error Code	Icon
Bus start fail	01	X
Bus over	02	X
Bus under	03	X
Bus unbalance	04	X
Inverter soft start failure	11	X
Inverter voltage high	12	X
Inverter voltage Low	13	X

Fault Event	Error Code	Icon
Inverter output short	14	
Battery voltage too high	27	
Battery voltage too low	28	
Over temperature	41	x
Overload	43	
Charger failure	45	x

### 3.8 Warning Indicator





Warning	Icon (flashing)	Alarm
Low battery		Sounding every second
Overload		Sounding twice every second
Battery is not connected		Sounding every second
Over charge		Sounding every second
Over temperature		Sounding every second
Charger failure		Sounding every second
Battery fault		Sounding every second
Out of bypass voltage range		Sounding every second
Bypass frequency unstable		Sounding every second
EEPROM error		Sounding every second

## Chapter 4 : Optional Accessories

No.	Item	Function
1	Mini SNMP IPv6 Card	Monitoring and control for the status of the UPS via a network system.
2	Mini Relay I/O Card	Increase of the dry contact number.
3	Mini MODBUS Card	Provision of the MODBUS communication function for the UPS.

## Chapter 5 : Troubleshooting

When an error occurs, please follow the table below to solve the according issues.

Symptom	Possible Cause	Remedy
No indication and alarm even though the mains is normal.	The AC input power is not connected well.	Check if the input power cord firmly connected to the mains.
	The AC input is connected to the UPS output.	Plug the AC input power cord to the AC input correctly.
The icons  and  are flashing on the LCD display and the alarm is sounding every second.	The external or internal batteries are incorrectly connected.	Check if all batteries are connected well.
Error code 27 or 28 is shown and the icon  is lighting on the LCD display and the alarm is continuously sounding.	Battery voltage is too high/low or the charger is fault.	Contact your local dealer or customer service.
The icons  and  are flashing on the LCD display and the alarm is sounding twice every second.	The UPS is overloaded.	Remove excess loads from the UPS output.
	The UPS is overloaded. Devices connected to the UPS are fed directly by the electrical network via the bypass.	Remove excess loads from the UPS output.
	After repetitive overloads, the UPS is locked in bypass mode. Connected devices are fed directly by the mains.	Remove excess loads from the UPS output first. Then shut down the UPS and restart it.

Symptom	Possible Cause	Remedy
Error code 43 is shown and the icon <b>OVER LOAD</b> is lighting on the LCD display and the alarm is continuously sounding.	The UPS shuts down automatically because of overload at the UPS output.	Remove excess loads from the UPS output and restart it.
Error code 14 is shown and the icon <b>SHORT</b> is lighting on the LCD display and the alarm is continuously sounding.	The UPS shuts down automatically because short circuit occurs on the UPS output.	Check output wiring and if connected devices are in short circuit status.
Error code 01, 02, 03, 04, 11, 12, 13, 41 or 45 is shown on the LCD display and the alarm is continuously sounding.	An UPS internal fault has occurred. There are two possible results: <ol style="list-style-type: none"> <li>1. The load is still supplied, but directly from AC power via bypass.</li> <li>2. The load is no longer supplied by the power.</li> </ol>	Contact your local dealer or customer service.
Battery backup time is shorter than nominal value.	Batteries are not fully charged.	Charge the batteries for at least 5 hours and then check capacity. If the problem still persists, consult your dealer.
	Batteries are damaged.	Contact your dealer to replace the batteries.

If the error that appears not list in the table above, please contact service personnel for possible cause and solution.

## Chapter 6 : Storage and Maintenance

- **Operation**

The UPS system contains no user-serviceable parts. If the battery service life (3~5 years at 25°C ambient temperature) has been exceeded, the batteries must be replaced. In this case, please contact your dealer.



**NOTE:**



Be sure to deliver the spent battery to a recycling facility or ship it to your dealer in the replacement battery packing material.

- **Storage**

Before storage, charge the UPS for 5 hours. Store the UPS covered and upright in a cool and dry location. During storage, recharge the battery in accordance with the following table:

Storage Temperature	Recharge Frequency	Charging Duration
-25°C ~ 40°C (-13°F ~ 104°F)	Every 3 months	1 ~ 2 hours
40°C ~ 45°C (104°F ~ 113°F)	Every 2 months	1 ~ 2 hours

## Appendix 1 : Technical Specifications

Model		NX 1kVA	NX 2kVA	NX 3kVA
Capacity		1000VA/ 900W	2000VA/ 1800W	3000VA/ 2700W
Input	Voltage Range	120-285 Vac (Based on load at 50%) 180-285 Vac (Based on load at 100%)		
	Frequency Range	40 ~ 70 Hz		
	Phase	Single phase with ground		
	Power Factor	≥ 0.99 @ Nominal Voltage (full load)		
Output	Nominal Voltage	208*1/220/230/240 Vac		
	Voltage Regulation	± 1%		
	Frequency Range (Online Mode)	50/60 Hz ± 3Hz*2		
	Frequency Range (Batt. Mode)	50/60 Hz ± 0.5%		
	Overload	Ambient temp. < 35°C <b>105% ~ 110%:</b> The UPS shuts down after 10 minutes in battery mode or transfers to bypass when the utility is normal. <b>110% ~ 130%:</b> The UPS shuts down after 30 seconds in battery mode or transfers to bypass when the utility is normal. <b>&gt; 130%:</b> The UPS shuts down after 3 seconds in battery mode or transfers to bypass when the utility is normal.		

Model		NX 1kVA	NX 2kVA	NX 3kVA
Output	Current Crest Ratio	3:1 (max)		
	Harmonic Distortion	≤ 3% (linear load); ≤ 6% (non-linear load)		
	Waveform (Batt. Mode)	Pure Sinewave		
Efficiency	AC Mode	88%	88%	90%
	ECO Mode	93%	94%	95%
Battery* <sup>3</sup>	Battery Voltage	24V	48V	72V
	Recharge Time	4 hours recover to 90% capacity (Typical)		
	Charging Current	1A		
Communication Interface		USB* <sup>3</sup> / Mini slot		
Physical	Dimensions W × D × H	145 × 282 × 220 mm (5.7" × 11.1" × 8.7")	145 × 397 × 220 mm (5.7" × 19.8" × 8.7")	190 × 421 × 318 mm (7.5" × 6.6" × 12.5")
	Net Weight	9.2 kg (20.3 lb)	16.8 kg (37 lb)	27 kg (59.5 lb)
Environment	Operating Temperature	0 ~ 40°C (32 ~ 104°F)		
	Operating Humidity	Relative Humidity 20 ~ 90% (non-condensing)		
	Operating Altitude	1000 m (3300 ft) (without derating)		



Model		NX 1kVA	NX 2kVA	NX 3kVA
Environment	Storage Temperature	-20 ~ 50°C (-4 ~ 122°F)		
	Storage Humidity	Relative Humidity 10 ~ 90%		
	Noise Level	< 50 dBA (AC mode)		



**NOTE:**

1. \*<sup>1</sup> The rated output power of the UPS needs to be de-rated to 70%.
2. \*<sup>2</sup> The output frequency is synchronized with the input line during online mode.
3. \*<sup>3</sup> OBA model features one external battery connector and one RS-232 interface.
4. Please refer to the rating label for the safety certification.
5. All specifications are subject to change without prior notice.

## Appendix 2 : Warranty

Seller warrants this product, if used in accordance with all applicable instructions, to be free from original defects in material and workmanship within the warranty period. If the product has any failure problem within the warranty period, Seller will repair or replace the product at its sole discretion according to the failure situation.

This warranty does not apply to normal wear or to damage resulting from improper installation, operation, usage, maintenance or irresistible force (i.e. war, fire, natural disaster, etc.), and this warranty also expressly excludes all incidental and consequential damages.

Maintenance service for a fee is provided for any damage out of the warranty period. If any maintenance is required, please directly contact the supplier or Seller.



### **WARNING:**

The individual user should take care to determine prior to use whether the environment and the load characteristic are suitable, adequate or safe for the installation and the usage of this product. The User Manual must be carefully followed. Seller makes no representation or warranty as to the suitability or fitness of this product for any specific application.

Version Date : 2023\_05\_09

## - Global Headquarter

### Taiwan

Delta Electronics Inc.  
39 Section 2, Huandong Road, Shanhua District,  
Tainan City 74144, Taiwan  
T +886 6 505 6565  
E [ups.taiwan@deltaww.com](mailto:ups.taiwan@deltaww.com)

## - Regional Office

### U.S.A

Delta Electronics (Americas) Ltd.  
46101 Fremont Blvd. Fremont, CA 94538  
T +1 510 344 2157  
E [ups.na@deltaww.com](mailto:ups.na@deltaww.com)

### Australia

Delta Energy Systems Australia Pty Ltd.  
Unit 20-21, 45 Normanby Road, Notting Hill VIC 3168, Australia  
T +61 3 9543 3720  
E [ups.australia@deltaww.com](mailto:ups.australia@deltaww.com)

### South America

Delta Electronics Brasil Ltda.  
Estrada Velha Rio-São Paulo, 5300 – Eugênio de Melo – CEP 12247-001  
São José dos Campos-SP-Brasil  
T +55 12 39322300  
E [ups.brazil@deltaww.com](mailto:ups.brazil@deltaww.com)

### Thailand

Delta Electronics (Thailand) Public Co.,Ltd.  
909 Soi 9, Moo 4, E.P.Z., Bangpoo Industrial Estate, Tambon Prakasa,  
Amphur Muang-samutprakarn, Samutprakarn Province 10280, Thailand  
T +662 709-2800  
E [ups.thailand@deltaww.com](mailto:ups.thailand@deltaww.com)

### China

Delta GreenTech (China) Co., Ltd.  
238 Minxia Road, Pudong, Shanghai, 201209 P.R.C  
T +86 21 5863 5678  
+86 21 5863 9595  
E [ups.china@deltaww.com](mailto:ups.china@deltaww.com)

### South Korea

Delta Electronics (Korea), Inc.  
1511, Byucksan Digital Valley 6-cha, Gasan-dong, Geumcheon-gu,  
Seoul, Korea, 153-704  
T +82-2-515-5303  
E [ups.south.korea@deltaww.com](mailto:ups.south.korea@deltaww.com)

### Singapore

Delta Electronics Int'l (Singapore) Pte Ltd.  
4 Kaki Bukit Ave 1, #05-04, Singapore 417939  
T +65 6747 5155  
E [ups.singapore@deltaww.com](mailto:ups.singapore@deltaww.com)

### India

Delta Electronics India Pvt. Ltd.  
Plot No. 43, Sector-35, HSIIDC, Gurgaon-122001, Haryana, India  
T +91 124 4874 900  
E [ups.india@deltaww.com](mailto:ups.india@deltaww.com)

### EMEA

Delta Electronics (Netherlands) BV  
Zandsteen 15, 2132MZ Hoofddorp, The Netherlands  
T +31 20 655 09 00  
E [ups.netherlands@deltaww.com](mailto:ups.netherlands@deltaww.com)

### Japan

Delta Electronics (Japan), Inc.  
2-1-14 Shibadaimon, Minato-Ku, Tokyo, 105-0012, Japan  
T +81-3-5733-1111  
E [jpstps@deltaww.com](mailto:jpstps@deltaww.com)

### UK

Delta Electronics (UK) Ltd.  
Eltek House Cleveland Road, Hemel Hempstead Industrial Estate,  
Hemel Hempstead, Hertfordshire, HP2 7EY  
T +44 1442 219355  
E [sales.gb@eltek.com](mailto:sales.gb@eltek.com)

