



Digitized Automation for a Changing World

Delta Open-Loop Variable-Torque Standard Drive VP3000 Series

High Efficiency, Stability, and Lower Harmonics Define this Next-Generation Standard Drive for the Fluid Industry

Open-Loop Variable-Torque Standard Drive VP3000 Series

The Delta VP3000 Series features excellent drive capabilities and stability. The VP3000 Series also provides a predictive maintenance (PdM) function for key components and offers an upgrade for lower harmonic improvement. Delta has introduced a new generation of drive for the fluid industry.

Power ranges from 0.75 to 630kW for various applications. High-power models are in a chassis design to fulfill effective space utilization and simple maintenance. The VP3000 is ideal for variable-torque equipment such as blowers, pumps, HVAC, water treatment and supply systems, compressors, and more.





Table of Contents

Introduction	3
Features	5
Functions	11
Specifications	15
Operating Environment	17
Wiring	18
Dimensions	19
Accessories	33
Ordering Information	37
Model Name Explanation	38

Fluid Automation Control Achieves a Total Win-Win for Production, Economy, and Environmental Sustainability

As global warming worsens and electricity costs rise sharply, enterprises around the world have started launching carbon reduction initiatives. Energy conservation and carbon emission reduction are vital issues for manufacturers to cope with and they are also part of corporate social responsibility.

Considering economic development and environmental protection, Delta has developed the Open-Loop Variable-Torque Standard Drive VP3000 Series for the fluid industry. The VP3000 Series can be widely applied in various fields such as water supply, wastewater treatment, HVAC, industrial water/electricity/gas supply, constant temperature control, and other applications to substantially enhance energy efficiency and reduce carbon emissions.

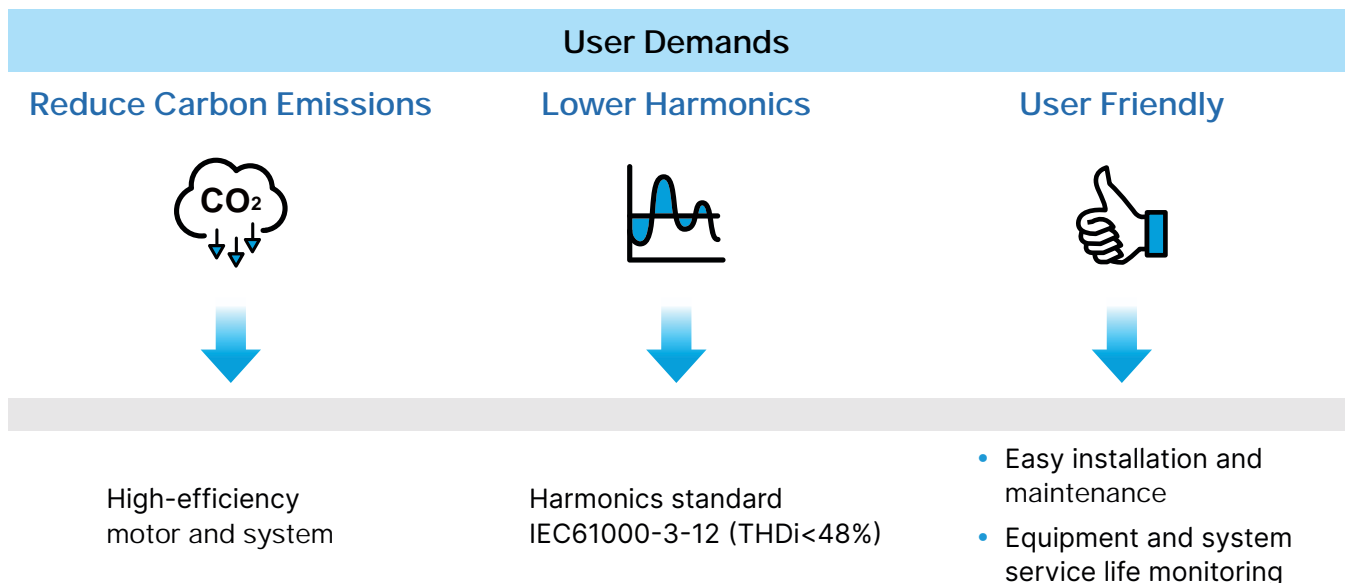



Air Compressors

Tunnel Ventilation

An Optimal Choice for the Fluid Industry



High Energy Efficiency

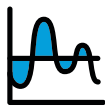

Lower Harmonics



Simple Maintenance



Optimal Panel Space



Long Equipment Lifespan



Stable Operation Without Downtime



Safety & Regulation Compliance



Functional Application

Features

Energy Efficiency

IM, PM, and high-efficiency SynRM motor control mode

Lower Harmonics

Better than EN 61000-3-12 standard, harmonics reaches min. 35%

PdM

Monitors the key components' service life for stable equipment operation

Enhanced PCB Coating

In compliance with the IEC 60721-3-3 class 3C3 standard

Compact Size

Slim type appearance design optimizes the panel front space





Functional Safety

Safe Torque Off (STO) SIL3

Custom Development Platform

Built-in PLC 20k steps, with drive and control integrated

High-Speed Network

Supports various industrial communication protocols

Interference Reduction

Built-in EMC filter, in compliance with EN61800-3 C2, C3

Keypad Option

LED Keypad: Basic digital display

LCD Keypad: Graphic display

LCD Keypad: Graphic display with built-in Bluetooth (Optional)

Features

Energy Efficiency

Controls Various High-Efficiency Motors

- Supports permanent magnet motors (PM), synchronous reluctance motors (SynRM), and induction motors (IM)
- High system integration adopts Delta's IE5 MSI SynRM for better efficiency, stability, and energy savings

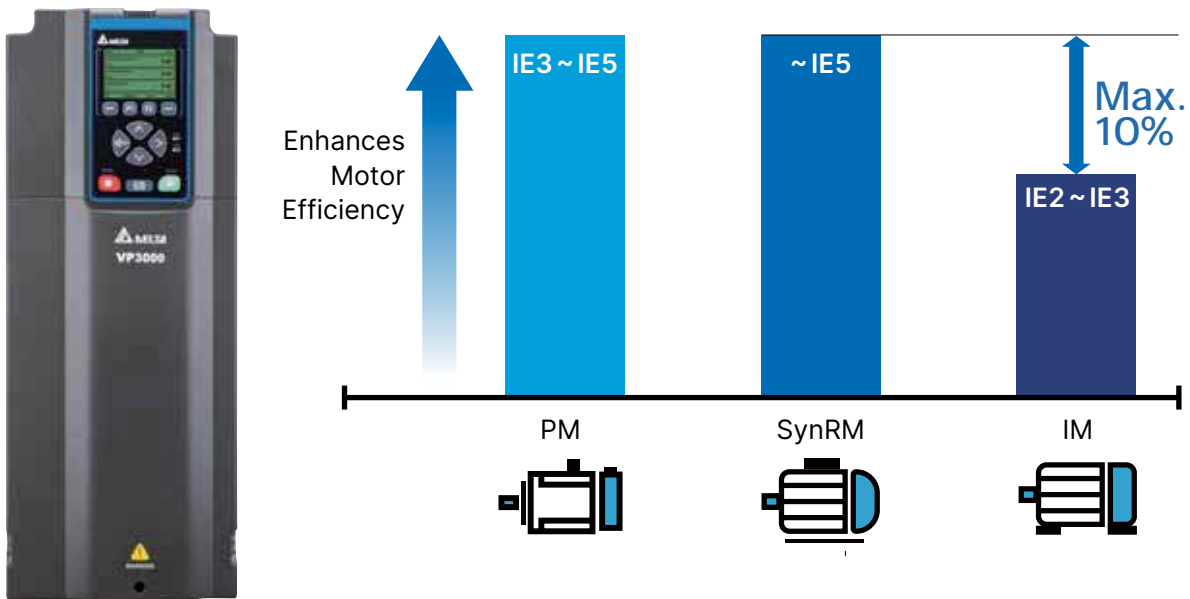

Lower Harmonics

Effective Harmonic Suppression

- Adopts lower harmonic technology to effectively suppress harmonics without an extra reactor*
- The lowest harmonics can reach THDi Min. 35%, much better than EN 61000-3-12 standard (THDi < 48%)

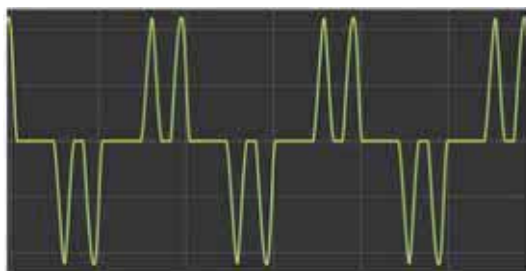

Motor drive without DC choke
THDi 107%



VP3000 with low harmonic technology
THDi 35%

*Available in lower harmonic models. For details, please refer to Model Name Explanation.

PdM

Predictive Maintenance (PdM)

Early maintenance notification for power module, capacitor, and cooling fan to allow replacement before end of service life and prevent sudden downtime

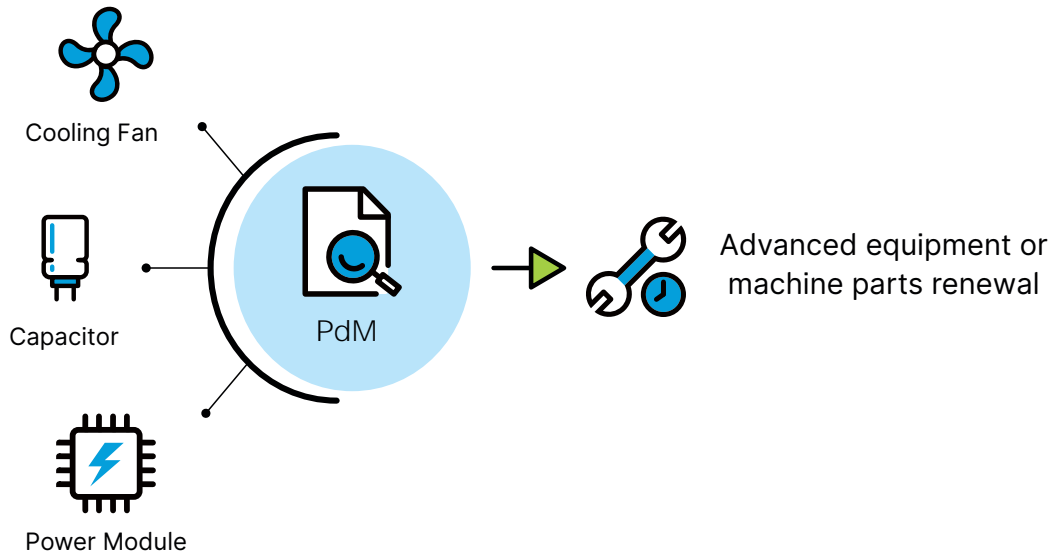

Enhanced PCB Coating

Enhances PCB Coating and Corrosion Resistance Capacity

- In workshops, materials such as oil, gas, dust or corrosive chemicals might spread over on the PCB through the heat-dissipating hole of the drive. With long-term changes in the temperature and humidity, the effects may corrode the PCB and further deteriorate components
- VP3000 helps strengthen the PCB coating and is compliant with the IEC 60721-3-3: 3C3 standard, which extends the lifespan of the drive operating in harsh environments or under corrosive gas exposure (e.g., salt mist, SO₂, O₃, H₂S, and more)

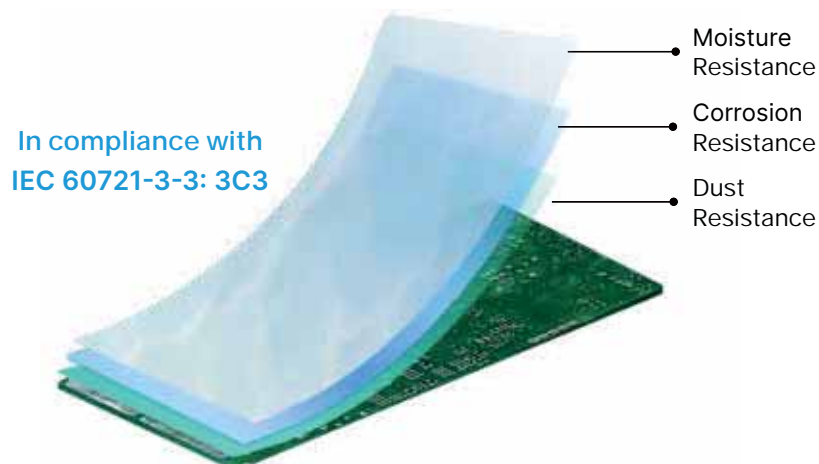

Features

Compact Size

Component Optimization Technology

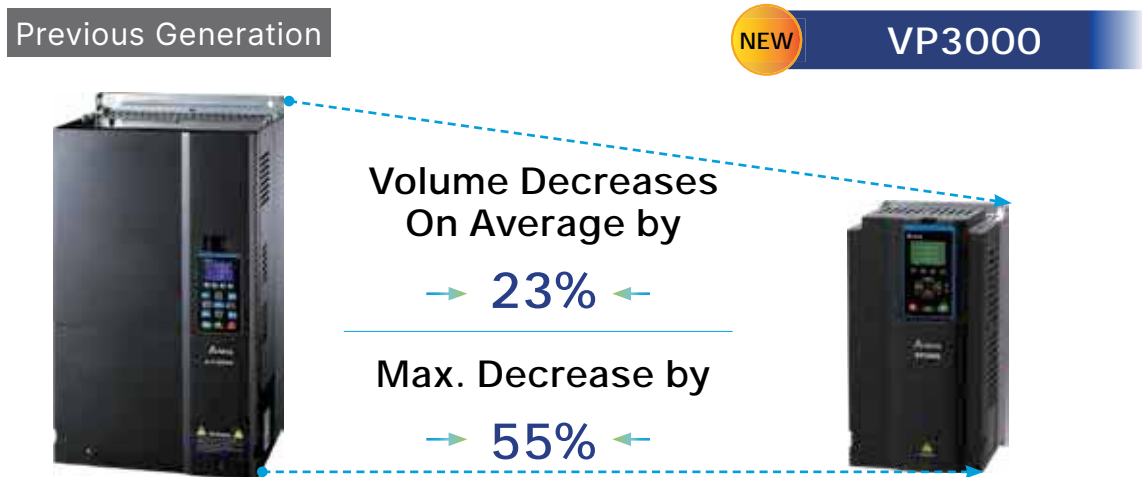

High Power Chassis Design

- High power models from 280 to 630 kW are in a chassis design, which substantially reduces the volume and cable configuration and optimizes the panel space
- The chassis design simplifies the operating process, so it can be easily disassembled and moved during maintenance



Functional Safety

Built-in Safe Torque Off (STO) Complies with International Standards

- Built-in STO SIL3
- Standards:
 - ISO 13849-1:2015 Category 3 PL e
 - EN 60204-1 Category 0
 - EN 61508 SIL3
 - EN 62061 SIL CL 3

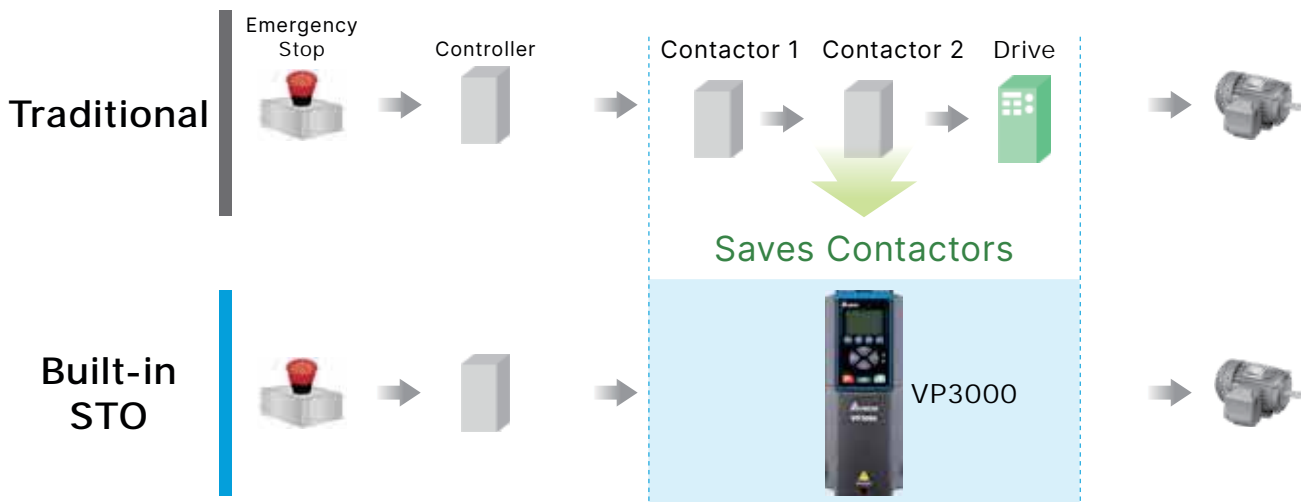

Custom Development Platform

Built-in Secondary Development Platform to Enhance Air Compressor Applications

- Built-in PLC 20k steps, with drive and control integrated



High-Speed Network

Supports Various Industrial Communication Protocols

- Built-in Modbus and BACnet MS/TP
- Communication Cards:

Modbus TCP

BACnet IP

EtherNet/IP™

DeviceNet™

PROFIBUS

PROFINET

CANopen

Functions

Automatic Energy Saving (AES) Mode Dedicated to IM Motors

As the VP3000 Series runs to a steady state, it automatically enters energy-saving mode and achieves optimal energy-saving benefits through self-learning motor parameters

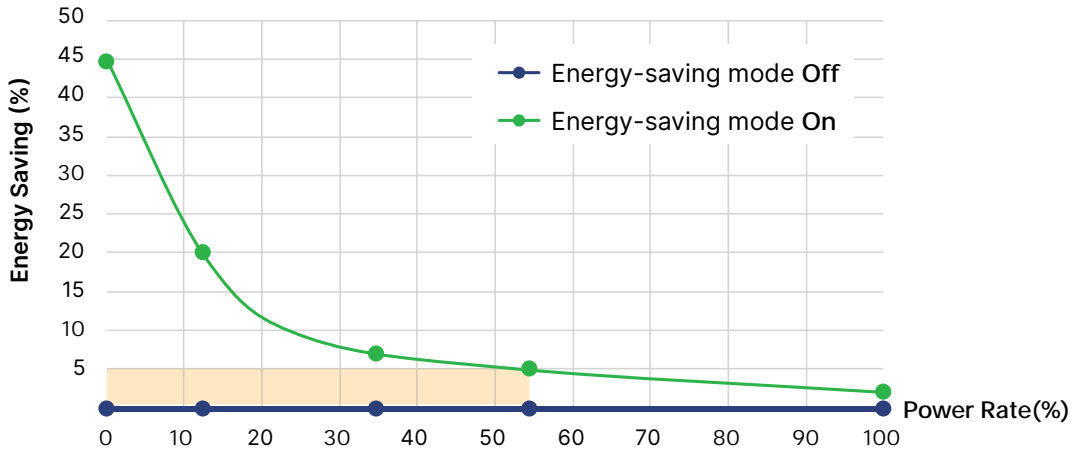

* The actual energy saving status depends on the operating platform

Multi-Pump Function

- Alternate operation: Multiple pumps operate alternately at regular intervals to facilitate maintenance and extend equipment life. The time period can be set in hours / days / weeks
- Constant pressure mode: Provides consistent energy-efficient water supply by staging or destaging operating pump quantities based on real-time demands
- Pump redundancy: In case of sudden failure of the operating drive, the backup drive will automatically take over the operation to maintain water supply

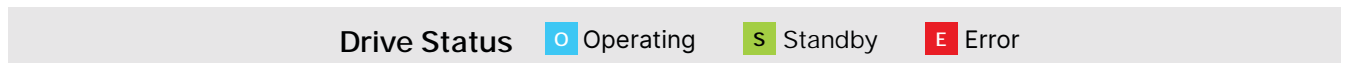
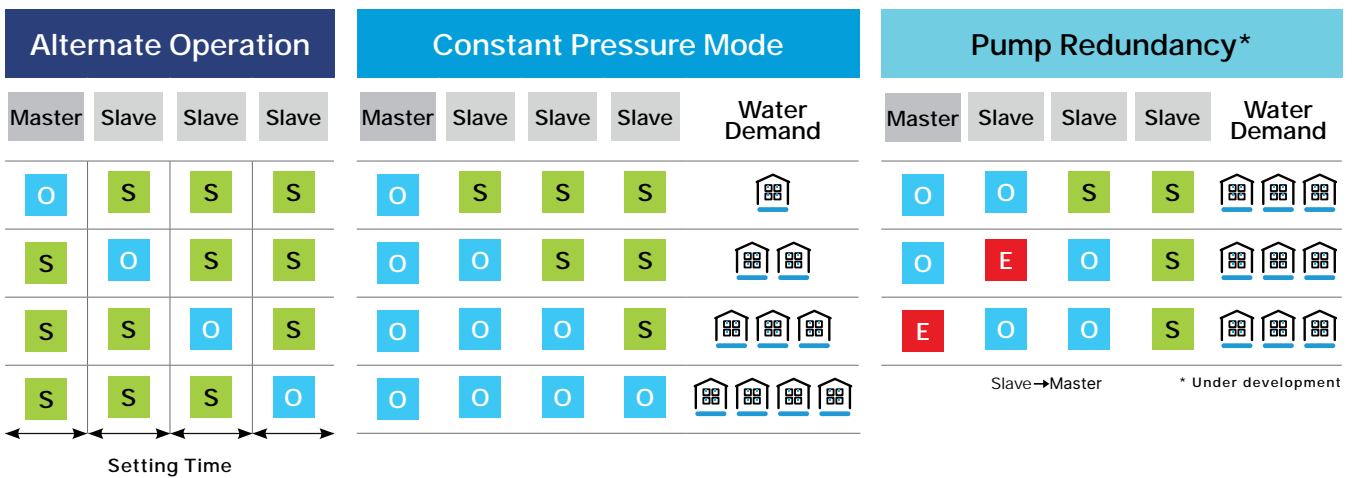

Fan Traction Energy Control (TEC)

Large industrial fans can effectively enhance the deceleration performance without a braking resistor, shorten the deceleration time by up to 40%, protect the drive from overvoltage, increase productivity, and stabilize equipment operation

Applications: Glass tempering furnace, large fan parking, and others

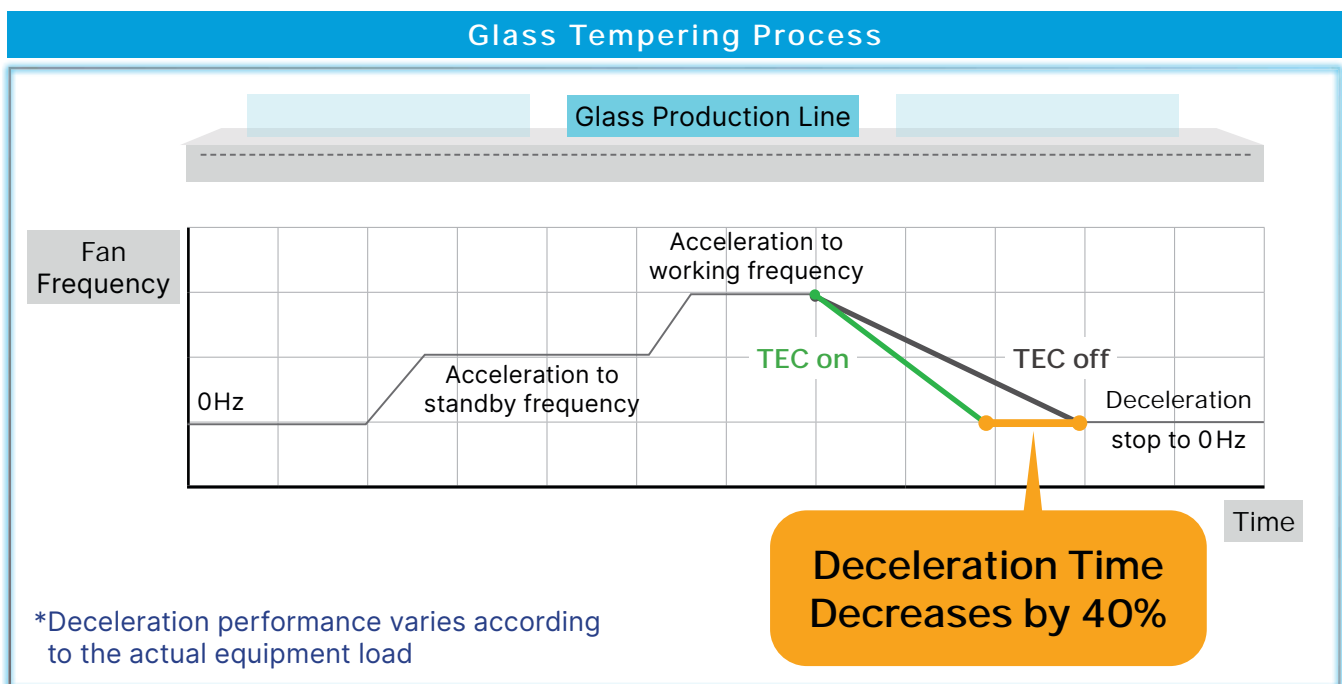

Built-in USB Port

Built-in USB port facilitates the drive setting, updating, real-time monitoring, and system tuning process

- No need of USB or RS-485 connectors
- Supports offline (drive power off) parameter setting/copying and system update

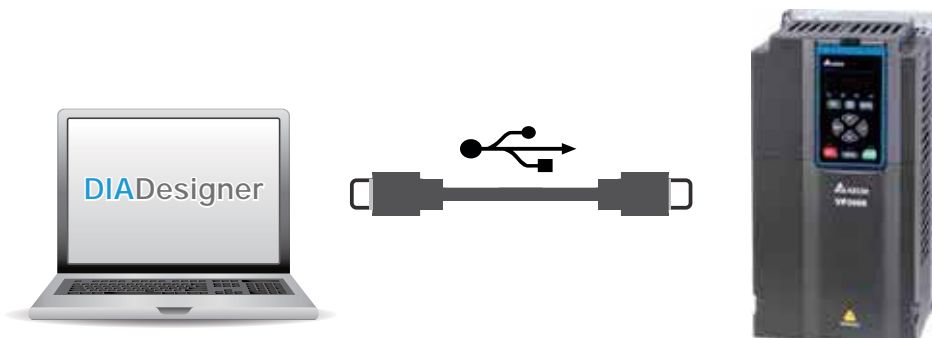

Functions

USB Type-C

- Connects to PC software DIASstudio
- Firmware update

Real-Time Clock Battery

Micro SD

- Signal logging function
- Multi-language package
- Parameter backup
- PLC program backup
- Firmware update

Control Circuit Terminals

- Analog signal terminal
- Relay output terminal

Communication Port

Built-in Modbus, BACnet

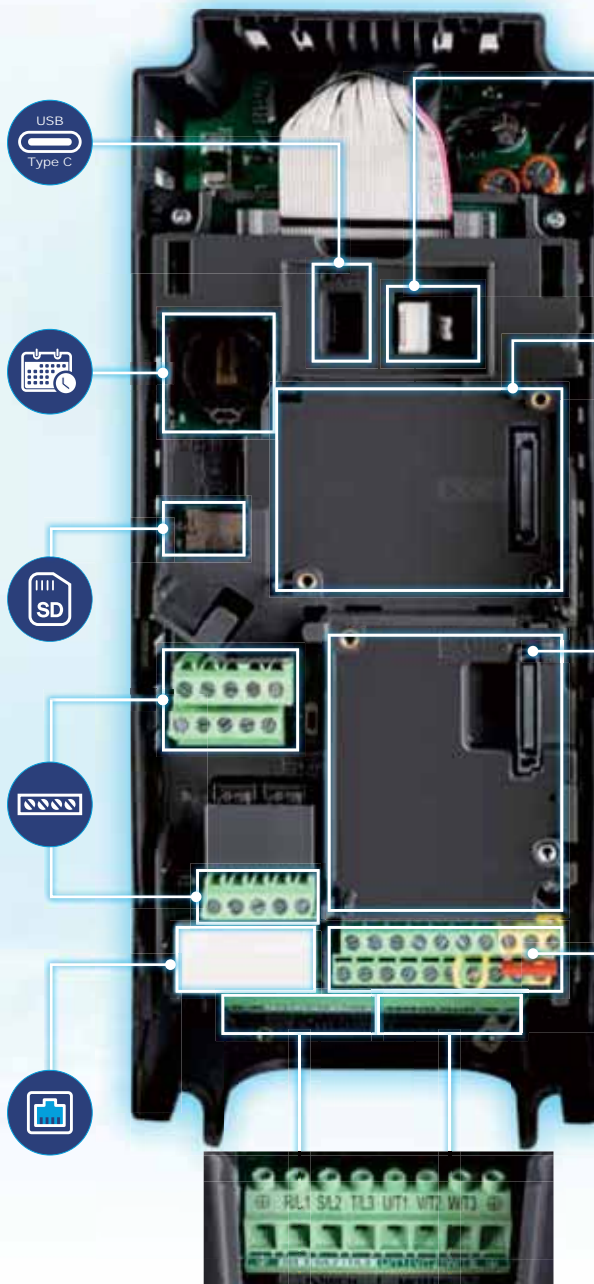

Keypad Slot
RJ45 connector

I/O Expansion Card Slot

- AI/AO
- DI/DO
- Relay

Communication Card Slot

- EtherNet IP
- Profibus DP
- Profitnet
- CANopen
- Modbus TCP
- DeviceNet

Control Circuit Terminals

- AI/AO, DI/DO terminal
- STO terminal

Main Power Input Terminal

Motor Output Terminal

Keypad

Models without EMC
(Built-in)
LED basic keypad
(KPV-CE02)



Models with EMC
(Built-in)
LCD graphic keypad
(KPV-CC01)



Models with Bluetooth & USB
(Optional)
LCD graphic keypad
(KPV-CC02)

*Under development



Industry-Specific Parameters	Multi-Language	Start Wizard	Communication
<ul style="list-style-type: none"> 01: User-defined 02: AHU 03: Fan 04: Pump 05: Compressor 	<ul style="list-style-type: none"> English French Spanish Portuguese German Italian Polish Russian Turkish Traditional Chinese Simplified Chinese 	<ul style="list-style-type: none"> Language Time Motor nameplate Acceleration and deceleration time I/O settings 	<ul style="list-style-type: none"> Bluetooth USB (Only KPV-CC02 has built-in USB)

Mobile APP*

- Remote control
- Setup wizard
- Dashboard
- Parameter setting
- Parameter backup
- Warning/Error logging
- I/O status
- Waveform monitoring
- Reports



*Under development

Specifications

460 V Models											
Frame Size	Model	Frame			Output				Input	Power	
	VFD_--VP43	IP20 UL Open Type ¹	IP20 UL Type 1 with C3 Filter	IP20 UL Type 1 with C2 Filter	Applicable Motor Output		Continuous Rated Output Current	Light Load Output Current	Max. Output Current	Rated Input Current	Power Supply Capacity
					(kW)	(HP)	I _{CON}	I _{ld}	I _{max}	(A) ^{*2}	(kVA) ^{*3}
A	3A0	A1	A2	-	0.75	1	3	2.9	3.7	4.2	3.3
	4A2	A1	A2	-	1.5	2	4.2	4	5.9	5.9	4.7
	5A6	A1	A2	-	2.2	3	5.6	5.3	7.2	7.8	6.2
	7A2	A1	A2	-	3	4	7.2	6.9	10.1	10.1	8.0
B	011	A1	A2	-	4	5	11	10	13	15.4	12
	013	B1	B2	-	5.5	7.5	13	12	16	18.2	15
C	018	B1	B2	-	7.5	10	18	17	22.7	25	20
	025	C1	C2	-	11	15	25	24	30.8	35	28
D	032	C1	C2	-	15	20	32	30.4	44.3	45	36
	038	C1	C2	-	18.5	25	38	36.1	56.9	53	42
E	045	D1	D2	D2	22	30	45	43	67.9	45	36
	062	D1	D2	D2	30	40	62	59	76.3	62	49
F	073	E1	E2	E2	37	50	73	70	104	73	58
	090	E1	E2	E2	45	60	90	87	122	90	72
G	110	F1	F2	F2	55	75	110	105	148	110	88
H	150	G1	G2	G2	75	100	150	143	185	150	120
	180	H1	H2	H2	90	125	180	171	247	180	143
I	220	H1	H2	H2	110	150	220	210	287	220	175
	260	I1	I2	I2	132	175	260	248	350	260	207
J	310	I1	I2	I2	160	215	310	295	418	310	247
	370	J1	J2	J2	185	250	370	352	455	370	295
K	395	J1	J2	J2	200	270	395	376	498	395	315
	460	K1	K2	K2	220	300	460	438	566	460	366
L	485	K1	K2	K2	250	340	485	461	597	485	386
	530	L	-	-	280	375	530	505	652	530	422
	616	L	-	-	315	425	616	587	757	616	491
	683	L	-	-	355	475	683	650	840	683	544
M	770	L	-	-	400	530	770	733	1020	770	613
	866	M	-	-	450	600	866	825	1065	866	690
	930	M	-	-	500	665	930	886	1143	930	741
	1K1	M	-	-	560	745	1100	1042	1345	1100	876
	1K2	M	-	-	630	840	1212	1154	1490	1212	966
I _{CON}				Continuous output current without load							
I _{ld}				110% of rated output current in light load: 1 minute for every 5 minutes							
I _{max}				Maximum output current: 2 sec. at start-up							
Rated Input Voltage				Three-phase, 380 ~ 480 V _{AC} (-15 ±10%)							
Rated Input Frequency				50/60Hz							
Frequency Tolerance				+15% (47 ~ 63Hz)							
Displacement Power Factor (cosθ)				0.98							
Efficiency (%)				Frame A ~ C: 97; Frame D ~ M: 98							
Braking Chopper				Not apply							
DC Choke				Frame A B C Without built-in DC choke; Frame D and above = Lower harmonic (THDi min.35%) ^{*4}							

* NOTE:

1. Frame L and M models are IP00 Chassis models.
2. The rated input current may fluctuate with the power supply impedance, power transformer, input reactors, DC chokes, and load.
3. The power supply capacity is calculated based on the rated input power and 480 VAC, which is used as a reference for selecting the power transformer capacity.
4. Refer to Model Name Explanation.
5. For high altitude, high ambient temperature, high carrier frequency, and advanced motor vector control, refer to the Derating in the user manual.
6. Refer to the user manual for the default value of carrier frequency, adjustable range and derating curve.

General Specifications

Item	Specifications	
Control Characteristics	Control Mode	PWM control
	Control Method	1: V/F, 2: SVC, 3: PM sensorless, 4: SynRM sensorless
	Starting Torque	Reach up to 150% or above at 0.5 Hz
	V/F Curve	4 point adjustable V/F curve and square curve
	Speed Response Ability	IMVF, IMSVC: 1:50 IMFOC sensorless: 1:100 PMSVC: 1:20 PMFOC sensorless: 1:50
	Torque Limit	In FOC mode, torque quadrants can be set separately via parameters
	Torque Accuracy	±5%
	Max. Output Frequency (Hz)	599.00 Hz
	Frequency Output Accuracy	Digital command: ±0.01%, -10°C ~ +40°C Analog command: ±0.1%, 25 ± 10°C
	Output Frequency Resolution	Digital command: 0.01 Hz Analog command: 0.03 x max. output frequency / 60 Hz (±11-bit)
	Overload Tolerance	Rated output current is 110%: 1 minute for every 5 minutes
	Frequency Setting Signal	0 ~ +10 V, 4 ~ 20 mA, 0 ~ 20 mA
	Accel. / Decel. Time	0.00 ~ 600.00 / 0.0 ~ 6,000.0 seconds
	Main Control Function	Momentary power loss ride thru, Speed search, Over-torque detection, Torque limit, 16-step speed (Max.), Accel./Decel. time switch, S-curve accel./decel., Three-wire sequence, Auto-Tuning, Dwell, Slip compensation, Torque compensation, JOG frequency, Frequency upper/lower limit settings, DC injection braking at start/stop, High slip braking, Energy saving control, Modbus communication (RS-485 RJ45, Max. 115.2 Kbps)
Fan Control	Frame A ~ F: ON / OFF switch control Frame G and above: PWM control	
Protection Characteristics	Motor Protection	Electronic thermal relay protection
	Over-Current Protection	Over-current protection for 195% rated current
	Over-Voltage Protection	460 V models: drive stops running when DC bus voltage exceeds 820 V
	Over-Temperature Protection	Built-in temperature sensor
	Stall Prevention	Stall prevention during acceleration, deceleration, and running independently
	Restart After Instantaneous Power Failure	Parameter setting up to 20 seconds
	Grounding Leakage Current Protection	Leakage current is higher than 50% of rated current of the AC motor drive
Certifications	CE Low Voltage Directive (LVD) 2014 / 35 / EU, EN61800-5-1 EMC Directive 2014/35/EU, EN61800-3 UL61800-5-1/CSA C22.2 No.274 WEEE 2012/19/EU, RoHS 2011/95/ Quality assurance system ISO 9001 and Environmental system ISO 14001	
Safety Functions	Safe Torque Off (STO per EN/IEC61800-5-2) TUV Rheinland certification IEC62061/IEC61508, SIL CL3 EN ISO13849-1, Cat.3/PL d	

*NOTE:

1. Max. output current setting changes with the carrier wave and control mode.
2. According to motor protection requirements, adjust the protection level through drive internal parameters.

Operating Environment

DO NOT expose the AC motor drive to harsh environments, such as dust, direct sunlight, corrosive / flammable gasses, humidity, liquid or vibrations. The salts in the air must be less than 0.01 mg/cm² per year.

Environment	Installation Location	IEC60364-1/IEC60664-1 Pollution degree 2, indoor use only	
	Surrounding Temperature (°C)	Storage/Transportation	-25 ~ +70
	Rated Humidity (%)	Max. 95. Only allowed in non-condensation, non-frost, non-conductive environment	
	Air Pressure (kPa)	Operation/Storage	86 ~ 106
		Transportation	70 ~ 106
	Pollution Level	IEC60721-3-3	
		Operation	Class 3C3; Class 3S2
		Storage	Class 1C2; Class 1S2
		Transportation	Class 2C2; Class 2S2
	If the AC motor drive is to be used in a harsh environment with a high level of contamination (e.g., dew, water, dust), make sure it is installed in an environment qualified for IP54 such as in a cabinet.		
Altitude	Operation	If the AC motor drive is installed at an altitude 0 ~ 1,000 m, follow normal operation restriction. If it is installed at altitude over 1,000m, decrease 1% of rated current or lower 0.5°C of temperature for every 100m increase in altitude. Maximum altitude for Corner Grounded TN system is 2,000m. Maximum altitude for 480 V _{AC} input voltage is 2,000m. Maximum altitude for 380 V _{AC} input voltage is 4,000m.	
Package Drop	Storage/Transportation	ISTA procedure 1A (according to weight) IEC60068-2-31	
Vibration	1.0mm, peak to peak value range from 2Hz to 13.2Hz; 0.7G ~ 1.0G range from 13.2Hz to 55Hz; 1.0G range from 55Hz to 512Hz. Comply with IEC 60068-2-6.		
Impact	IEC/EN 60068-2-27		
Operation Position	Max. allowed offset angle ± 10° (under normal installation position)		

Operation Temperature and Protection Level

Frame	Top Cover	Conduit Box	Protection Level	Operation Temperature
A1 ~ K1	Yes	N/A	IP20/UL Open Type	-20°C ~ 50°C
A2 ~ K2	Yes	Yes	IP20/UL Type1	-20 ~ 45°C
L, M	N/A	N/A	IP00 Chassis	-20°C ~ 50°C

Wiring

Wiring Diagram for Main Circuit Terminals

Applicable for all frame sizes

Input: 3-phase power

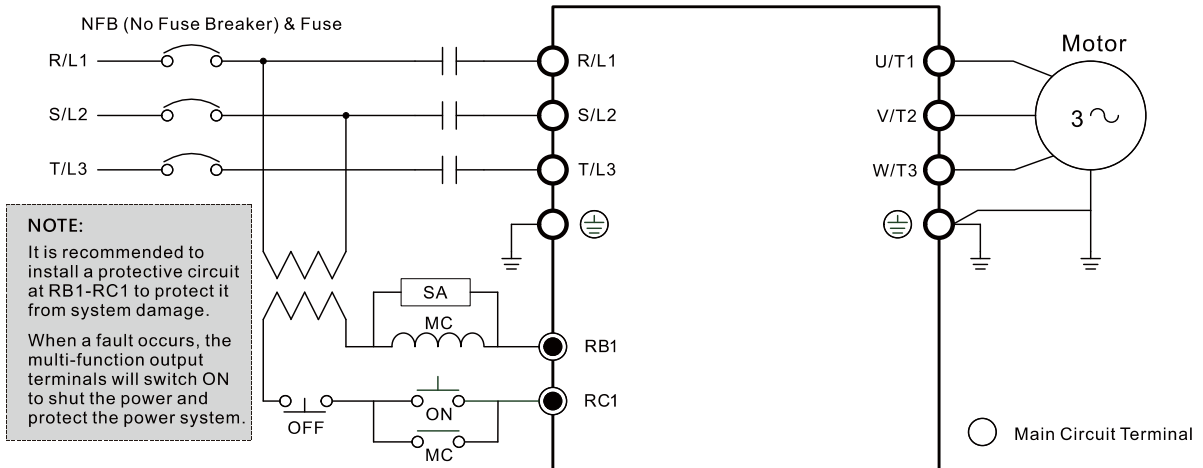

Wiring Diagram for Control Terminals

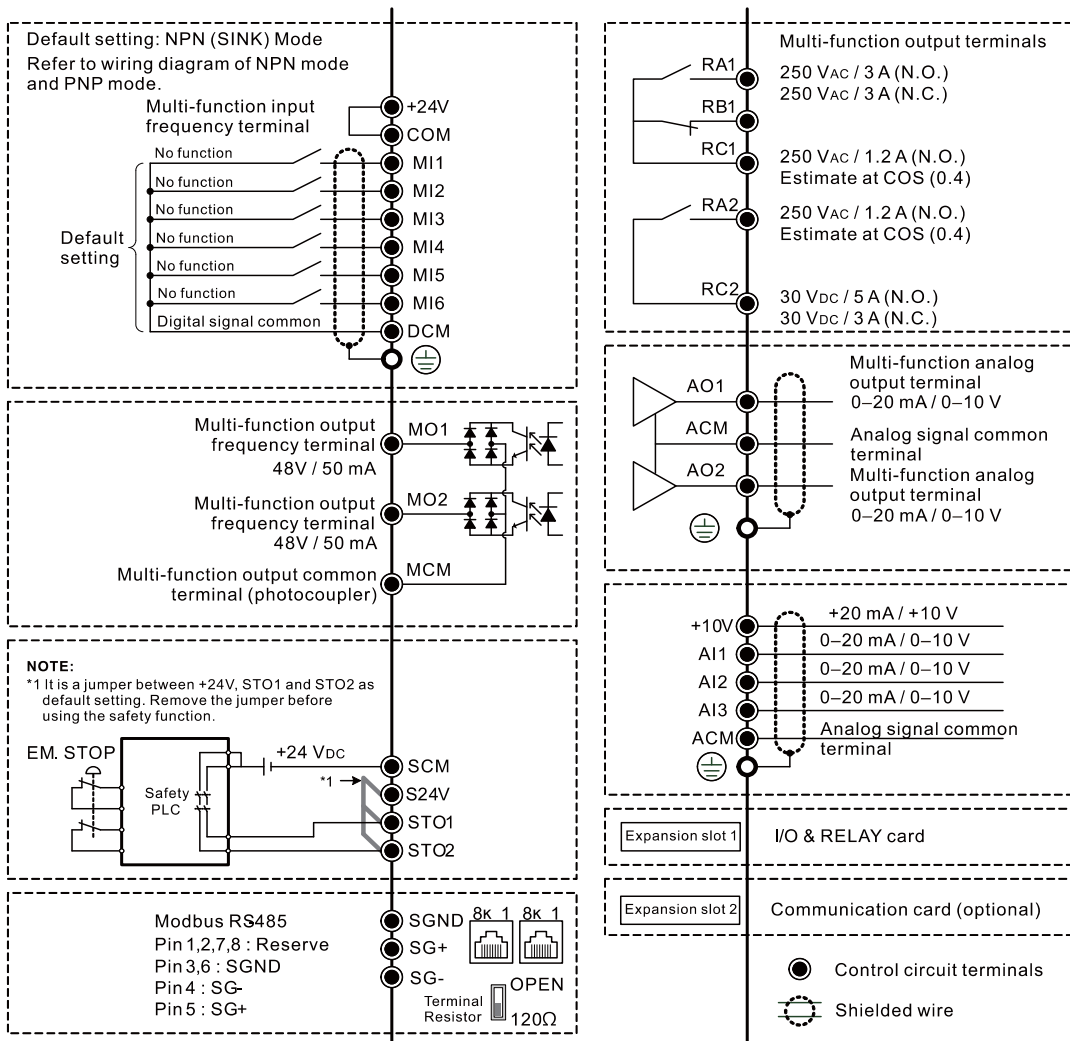

Dimensions

Digital Keypad

LCD graphic keypad
(KPV-CC01)

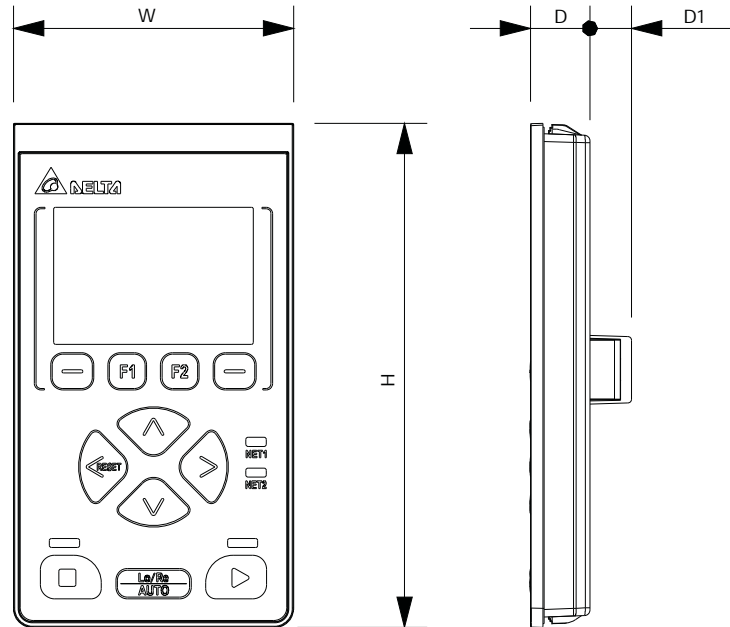

LED basic keypad
(KPV-CE02)

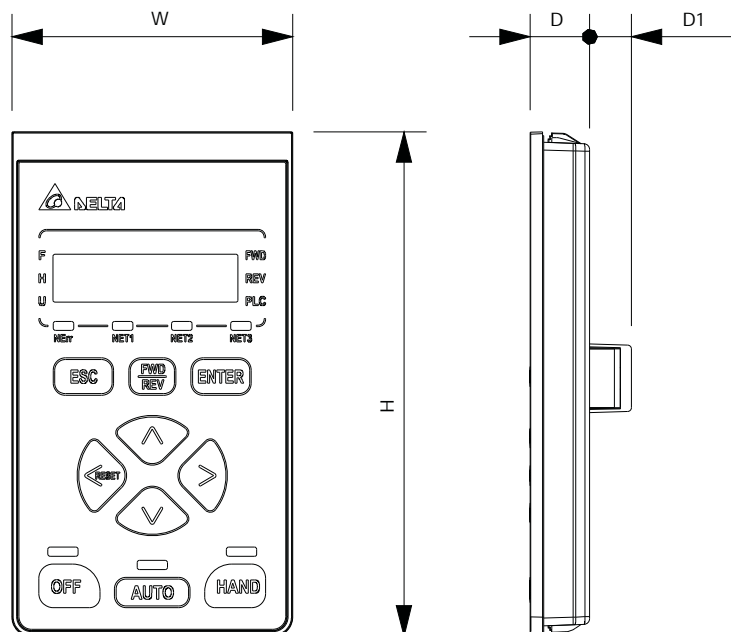

	W	H	D	D1
mm	74.0	132.5	15.7	11.0
inch	2.91	5.22	0.62	0.43

Frame A1

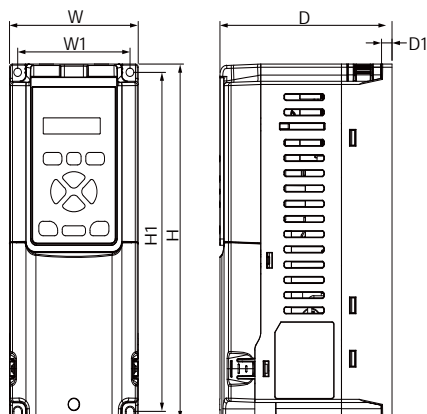

Model

VFD3A0VP43ANTAA
 VFD4A2VP43ANTAA
 VFD5A6VP43ANTAA
 VF7A2VP43ANTAA
 VFD011VP43ANTAA

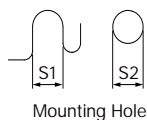
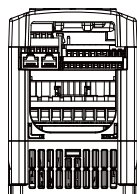

Mounting Hole

Weight: 1.71 kg

Frame		W	W1	H	H1	D	D1	S1	S2
A1	mm	110	96	280	267	147	9	6.5	6.5
	inch	4.33	3.78	11.02	10.51	5.79	0.35	0.26	0.26

Frame A2

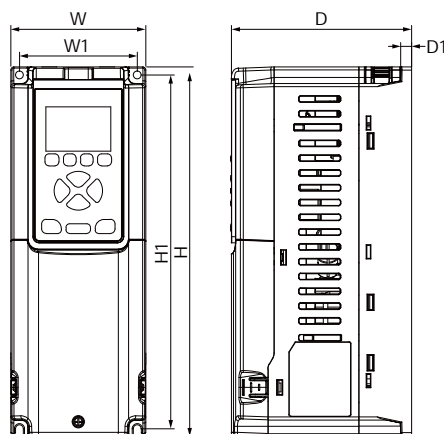

Model

VFD3A0VP43BFTAA
 VFD4A2VP43BFTAA
 VFD5A6VP43BFTAA
 VFD7A2VP43BFTAA
 VFD011VP43BFTAA

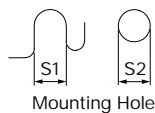
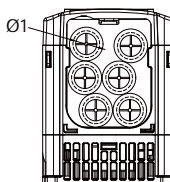

Mounting Hole

Weight: 1.95 kg

Frame		W	W1	H	H1	D	D1	S1	S2	Ø1
A2	mm	110	96	300	287	147	9	6.5	6.5	22.2
	inch	4.33	3.78	11.81	11.3	5.79	0.35	0.26	0.26	0.87

Dimensions

Frame B1

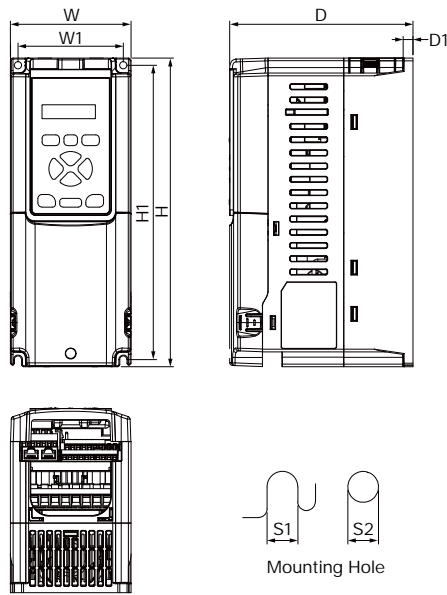

Model

VFD013VP43ANTAA
VFD018VP43ANTAA

Weight: 1.97kg

Frame		W	W1	H	H1	D	D1	S1	S2
B1	mm	110	96	280	267	167	9	6.5	6.5
	inch	4.33	3.78	11.02	10.51	6.57	0.35	0.26	0.26

Frame B2

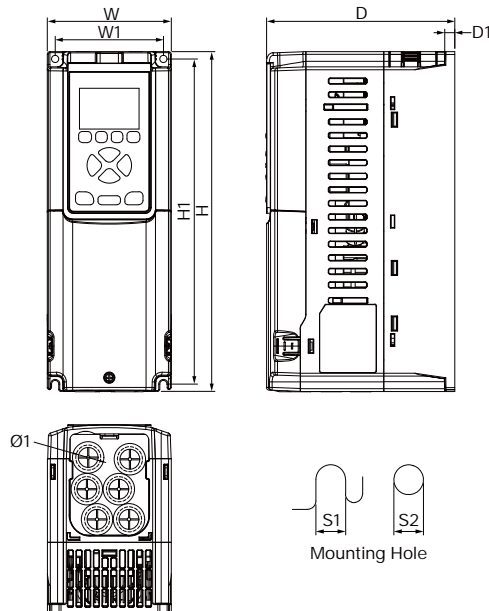

Model

VFD013VP43BFTAA
VFD018VP43BFTAA

Weight: 2.47kg

Frame		W	W1	H	H1	D	D1	S1	S2	Ø1
B2	mm	110	96.0	300.0	287	167	9	6.5	6.5	22.2
	inch	4.33	3.78	11.81	11.3	6.57	0.35	0.26	0.26	0.87

Frame C1

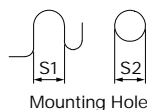
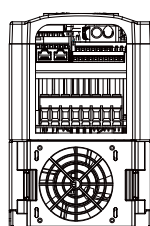
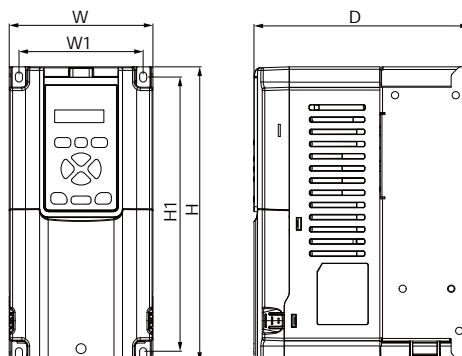

Model

VFD025VP43ANTAA
VFD032VP43ANTAA
VFD038VP43ANTAA

Weight: 5.6 kg

Frame		W	W1	H	H1	D	S1	S2
C1	mm	142	122.9	290	270	213	7	7
	inch	5.59	4.84	11.42	10.63	8.39	0.28	0.28

Frame C2

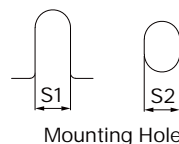
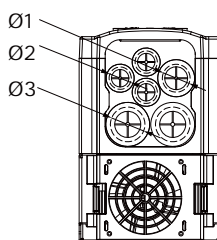
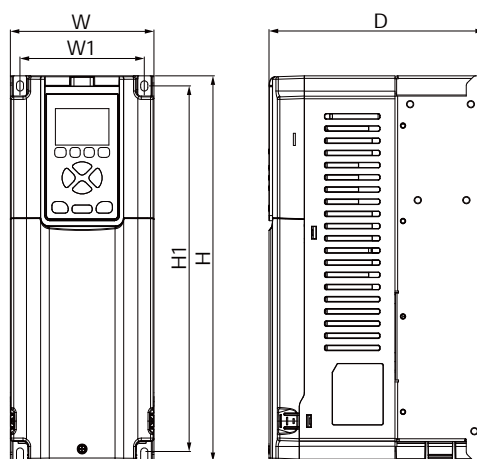

Model

VFD025VP43BFTAA
VFD032VP43BFTAA
VFD038VP43BFTAA

Weight: 6 kg

Frame		W	W1	H	H1	D	S1	S2	Ø1	Ø2	Ø3
C2	mm	142	122.9	380	360	213	7	7	27.8	22.2	34.5
	inch	5.59	4.84	14.96	14.17	8.39	0.28	0.28	1.09	0.87	1.36

Dimensions

Frame D1

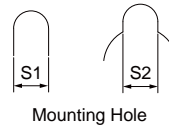
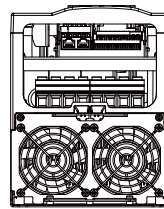
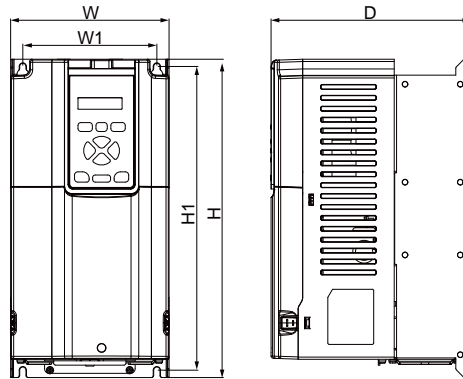

Model

VFD045VP43ANTCA
VFD062VP43ANTCA

Weight: 8.5 kg

Frame		W	W1	H	H1	D	S1	S2
D1	mm	175	148	350	334	221	7	7
	inch	6.89	5.83	13.78	13.15	8.7	0.28	0.28

Frame D2

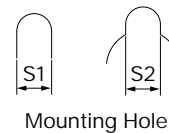
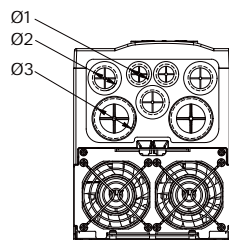
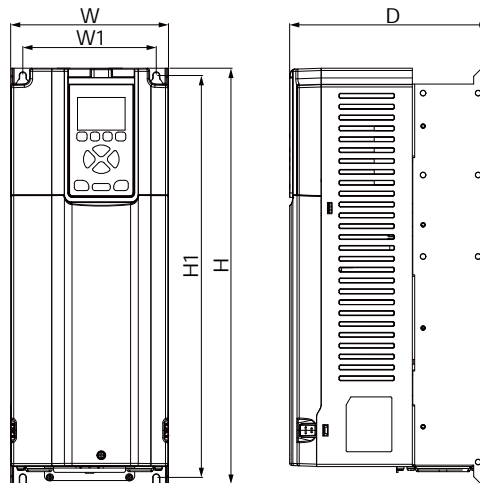

Model

VFD045VP43BFTCA
VFD062VP43BFTCA
VFD045VP43BSTCA
VFD062VP43BSTCA

Weight: 11 kg

Frame		W	W1	H	H1	D	S1	S2	Ø1	Ø2	Ø3
D2	mm	175	148	460	444	221	7	7	22.3	27.5	43.8
	inch	6.89	5.83	18.11	17.48	8.7	0.28	0.28	0.88	1.08	1.72

Frame E1

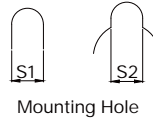
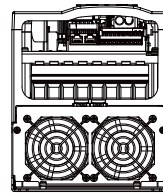
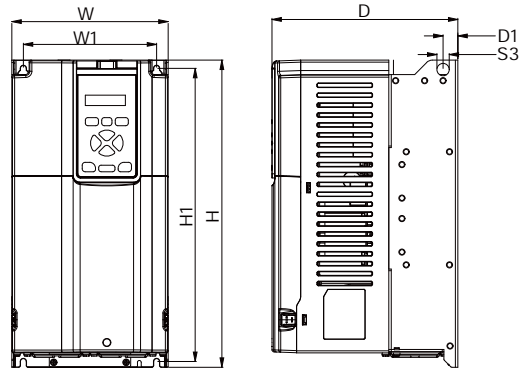

Model

VFD073VP43ANTCA
VFD090VP43ANTCA

Weight: 10.5 kg

Frame		W	W1	H	H1	D	D1	S1	S2	S3
E1	mm	190	162	372	355	226	18	7	7	15
	inch	7.48	6.38	14.65	13.98	8.9	0.71	0.28	0.28	0.59

Frame E2

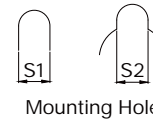
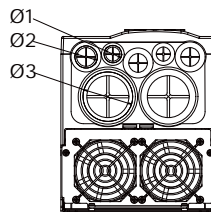
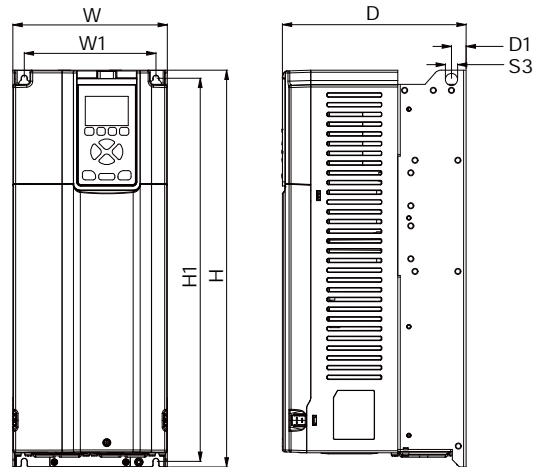

Model

VFD073VP43BFTCA
VFD090VP43BFTCA
VFD073VP43BSTCA
VFD090VP43BSTCA

Weight: 13 kg

Frame		W	W1	H	H1	D	D1	S1	S2	S3	Ø1	Ø2	Ø3
E2	mm	190	162	489	472	226	18	7	7	15	21.5	27.5	61
	inch	7.48	6.38	19.25	18.58	8.9	0.71	0.28	0.28	0.59	0.85	1.08	2.4

Dimensions

Frame F1

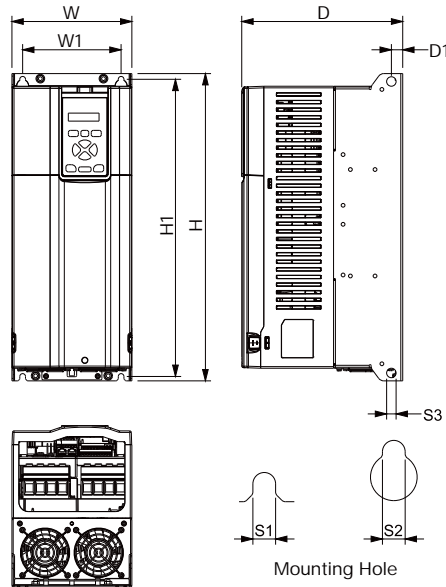

Model
 VFD110VP43AFTCA
 Weight: 14.4 kg

Frame		W	W1	H	H1	D	D1	S1	S2	S3
F1	mm	190	156	485	469	255	18	9	9	15
	inch	7.48	6.14	19.09	18.46	10.04	0.71	0.35	0.35	0.59

Frame F2

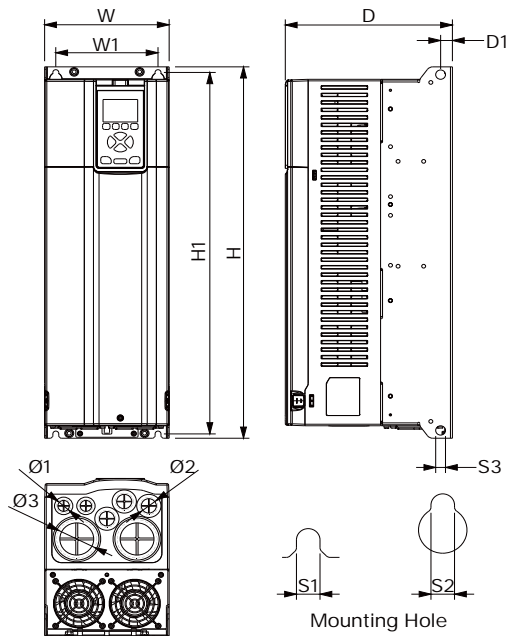

Model
 VFD110VP43BFTCA
 VFD110VP43BSTCA
 Weight: 17.6 kg

Frame		W	W1	H	H1	D	D1	S1	S2	S3	Ø1	Ø2	Ø3
F2	mm	190	156	595	579	255	18	9	9	15	21.5	27.5	61
	inch	7.48	6.14	23.43	22.8	10.04	0.71	0.35	0.35	0.59	0.85	1.08	2.4

Frame G1

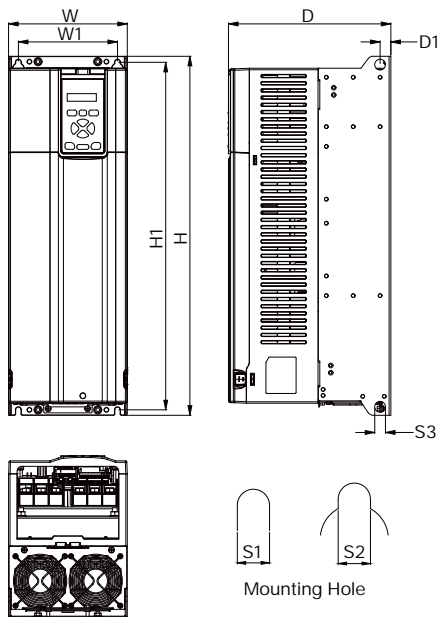

Model
VFD150VP43AFTCA
Weight: 23.8 kg

Frame		W	W1	H	H1	D	D1	S1	S2	S3
G1	mm	199	166	599	580	272	18	9	9	18
	inch	7.83	6.54	23.58	22.83	10.71	0.71	0.35	0.35	0.71

Frame G2

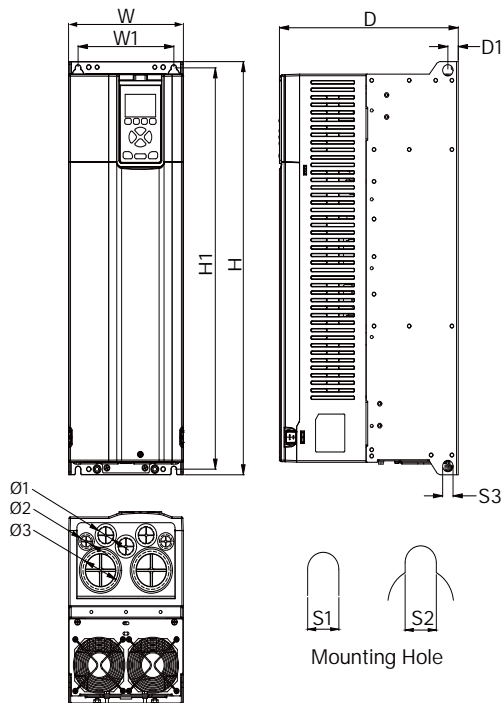

Model
VFD150VP43BFTCA
VFD150VP43BSTCA
Weight: 28.7 kg

Frame		W	W1	H	H1	D	D1	S1	S2	Ø1	Ø2	Ø3
G2	mm	199	166	660	641	310	18	9	9	28	22	61
	inch	7.83	6.54	25.98	25.24	12.2	0.71	0.35	0.35	1.1	0.87	2.4

Dimensions

Frame H1

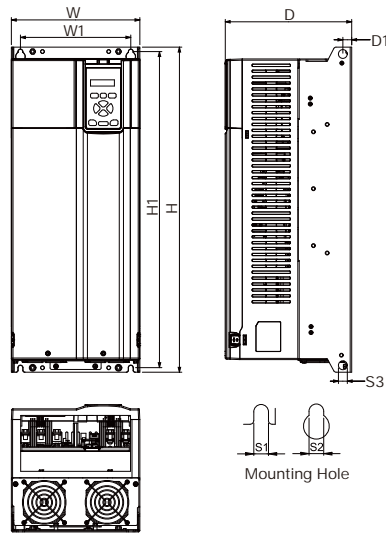

Model

VFD180VP43AFTCA
VFD220VP43AFTCA

Weight: 34.2 kg

Frame		W	W1	H	H1	D	D1	S1	S2	S3
H1	mm	262	225	660	641.8	258	18	9.5	9.5	18
	inch	10.31	8.89	25.98	25.27	10.16	0.71	0.37	0.37	0.71

Frame H2

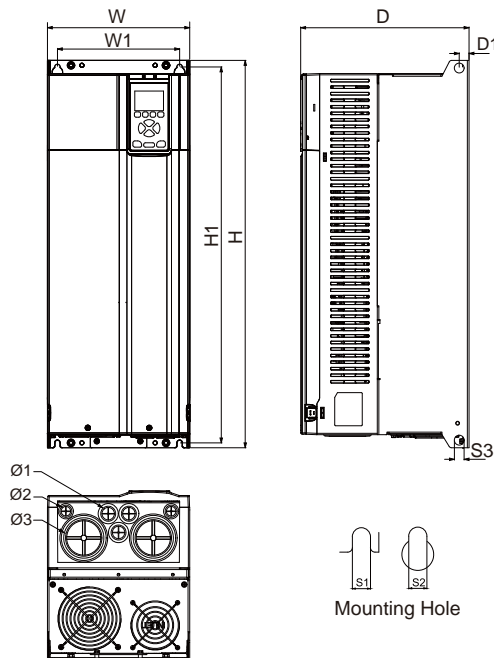

Model

VFD180VP43BFTCA
VFD220VP43BFTCA
VFD180VP43BSTCA
VFD220VP43BSTCA

Weight: 40.1 kg

Frame		W	W1	H	H1	D	D1	S1	S2	S3	Ø1	Ø2	Ø3
H2	mm	262	225	710	689	310	18	9.5	9.5	18	27.5	22.3	74.0
	inch	10.31	8.89	27.95	27.13	12.2	0.71	0.37	0.37	0.71	1.08	0.87	2.91

Frame I1

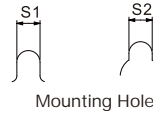
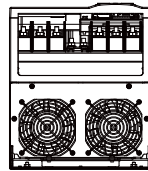
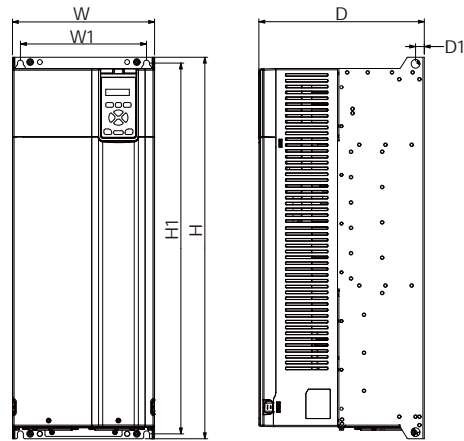

Model

VFD260VP43AFTCA
VFD310VP43AFTCA

Weight: 46.1kg

Frame		W	W1	H	H1	D	D1	S1	S2
I1	mm	293	260	783	761	341	18	12	12
	inch	11.54	10.24	30.83	29.96	13.43	0.71	0.47	0.47

Frame I2

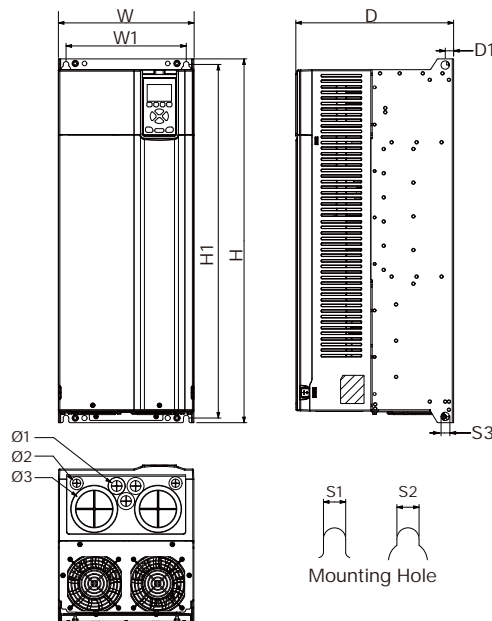

Model

VFD260VP43BFTCA
VFD310VP43BFTCA
VFD260VP43BSTCA
VFD310VP43BSTCA

Weight: 48.6 kg

Frame		W	W1	H	H1	D	D1	S1	S2	Ø1	Ø2	Ø3
I2	mm	293	260	783	761	341	18	12	12	27.5	21.5	91
	inch	11.54	10.24	30.83	29.96	13.43	0.71	0.47	0.47	1.08	0.85	3.58

Dimensions

Frame J1

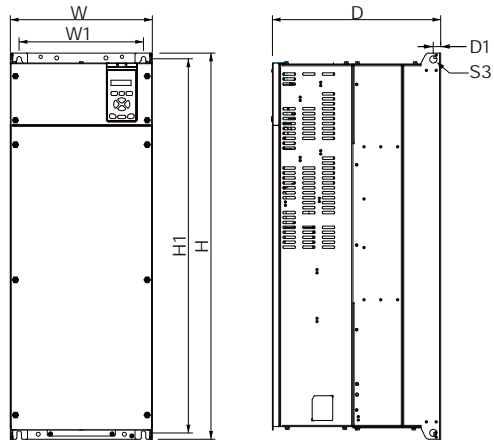

Model

VFD370VP43AFTCA
VFD395VP43AFTCA

Weight: 74.2 kg

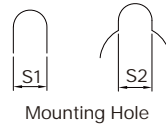
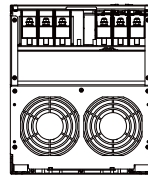

Frame		W	W1	H	H1	D	D1	S1	S2	S3
J1	mm	346	303	937	908	410	18	11	11	18
	inch	13.62	11.93	36.89	35.75	16.14	0.71	0.43	0.43	0.71

Frame J2

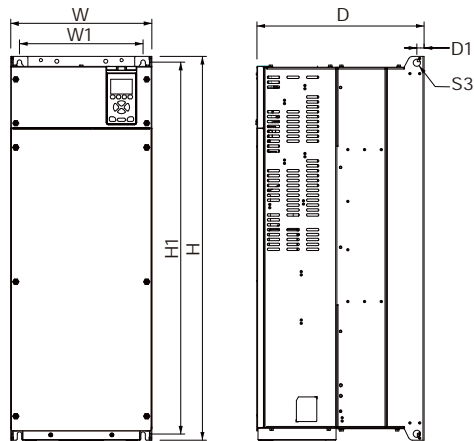

Model

VFD370VP43BFTCA
VFD395VP43BFTCA
VFD370VP43BSTCA
VFD395VP43BSTCA

Weight: 82.5 kg

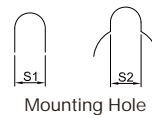
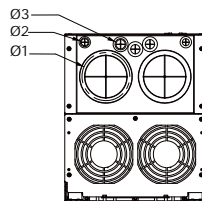

Frame		W	W1	H	H1	D	D1	S1	S2	S3	Ø1	Ø2	Ø3
J2	mm	346	303	937	908	410	18.0	11	11	18	117.3	21.5	27.5
	inch	13.62	11.93	36.89	35.75	16.14	0.71	0.43	0.43	0.71	4.62	0.85	1.08

Frame K1

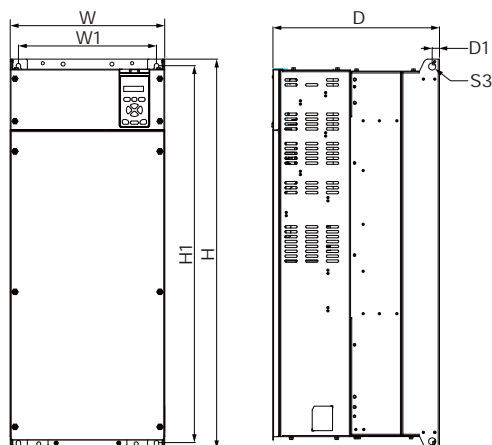

Model

VFD460VP43AFTCA
VFD485VP43AFTCA

Weight: 90kg

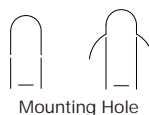
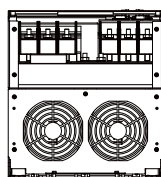

Mounting Hole

Frame		W	W1	H	H1	D	D1	S1	S2	S3
K1	mm	380	340	955	924	410	18	11	11	18
	inch	14.96	13.39	37.6	36.38	16.14	0.71	0.43	0.43	0.71

Frame K2

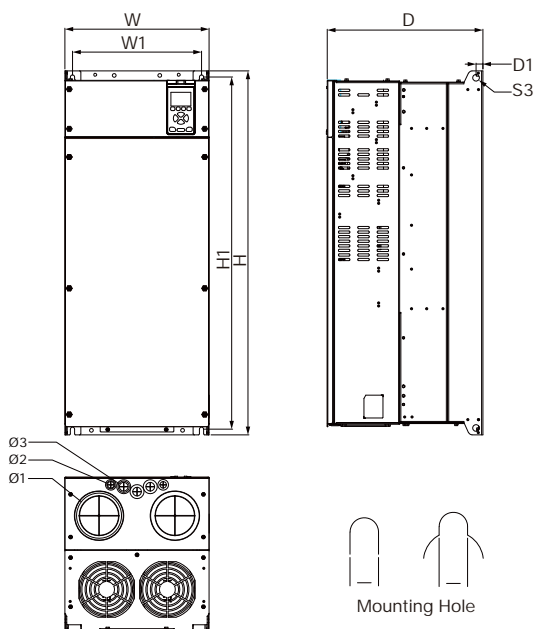

Model

VFD460VP43BFTCA
VFD485VP43BFTCA
VFD460VP43BSTCA
VFD485VP43BSTCA

Weight: 97kg

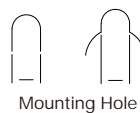
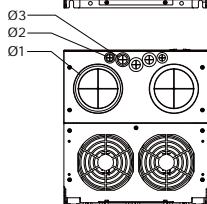

Mounting Hole

Frame		W	W1	H	H1	D	D1	S1	S2	S3	Ø1	Ø2	Ø3
K2	mm	380	340	955	924	410	18	11	11	18	117.3	21.5	27.5
	inch	14.96	13.39	37.6	36.38	16.14	0.71	0.43	0.43	0.71	4.62	0.85	1.08

Dimensions

Frame L

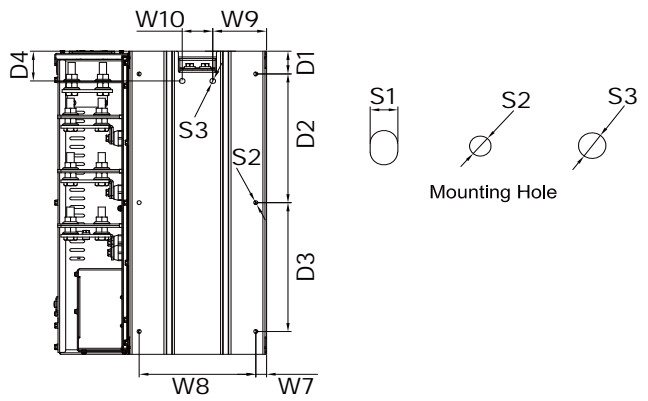
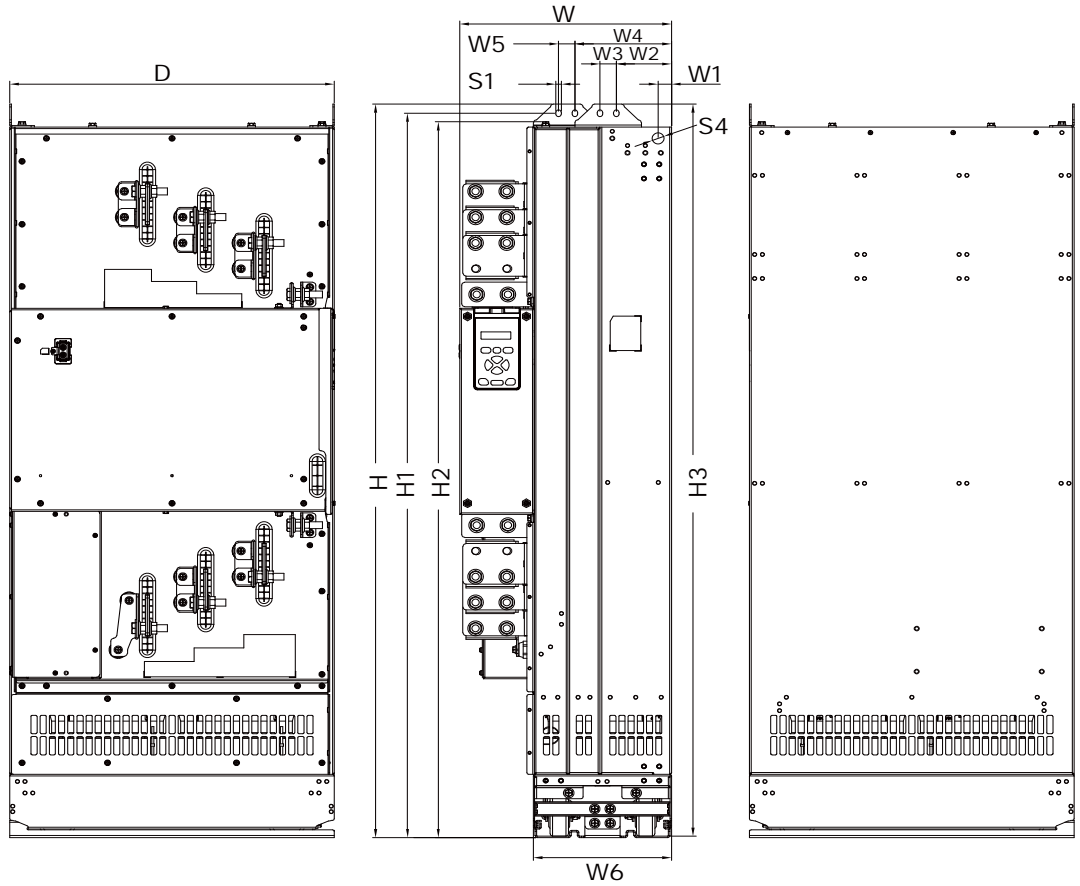

Model

VFD 530 43SHTCA
 VFD 616 43SHTCA
 VFD 683 43SHTCA
 VFD 770 43SHTCA

Weight: 128.4 kg

Frame	W	W1	W2	W3	W4	W5	W6	W7	W8	W9	W10	H	
L1	mm	345	22	90	26.5	157.5	26.5	225	17.5	190	87.5	50	1281
	inch	13.58	0.87	3.54	1.04	6.2	1.04	8.86	0.69	7.48	3.44	1.97	50.43
Frame	H1	H2	H3	D	D1	D2	D3	D4	S1	S2	S3	S4	
L1	mm	1265	1250	1278.5	529	39.5	225	225	52	9	7	9	20
	inch	49.8	49.21	50.33	20.83	1.56	8.86	8.86	2.05	0.35	0.28	0.35	0.79

Frame M

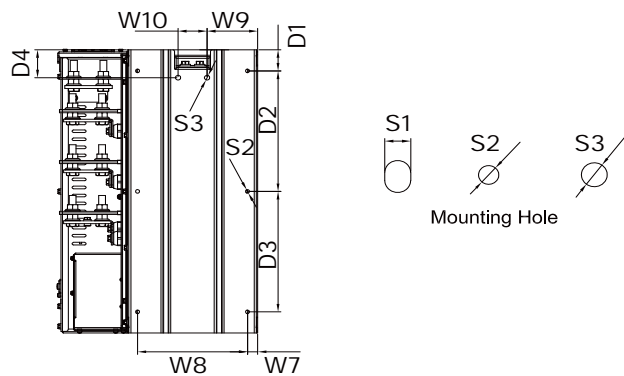
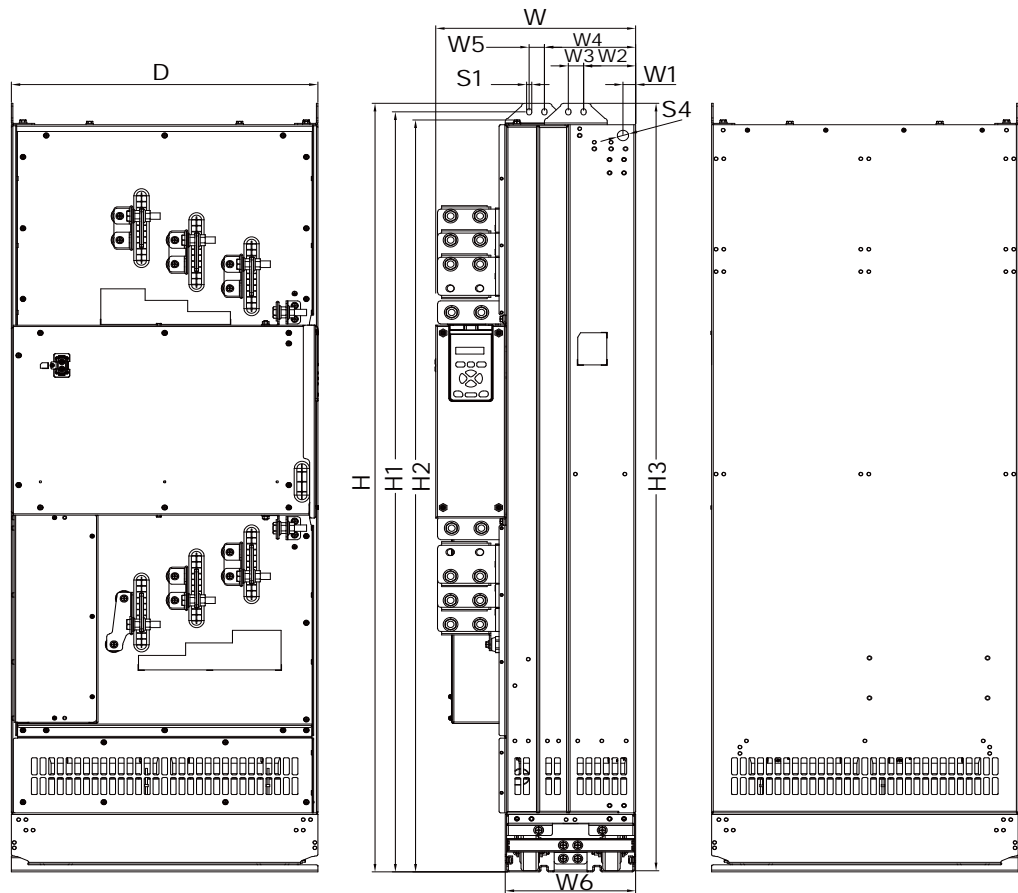

Model

VFD 866 VP43SHTCA
 VFD 930 VP43SHTCA
 VFD 1K1 VP43SHTCA
 VFD 1K2 VP43SHTCA

Weight: 170.4 kg

Frame	W	W1	W2	W3	W4	W5	W6	W7	W8	W9	W10	H	
M1	mm	345	22	90	26.5	157.5	26.5	225	17.5	190	87.5	50	1436
	inch	13.58	0.87	3.54	1.04	6.2	1.04	8.86	0.69	7.48	3.44	1.97	56.54
Frame	H1	H2	H3	D	D1	D2	D3	D4	S1	S2	S3	S4	
M1	mm	1420	1405	1433.5	529	39.5	225	225	52	9	7	9	20
	inch	55.91	55.31	56.44	20.83	1.56	8.86	8.86	2.05	0.35	0.28	0.35	0.79

Accessories

Relay Extension Card

- EMV-R6AA

	Terminals	Descriptions
	RA10 ~ RA15 RC10 ~ RC15	Refer to Pr. 02-36 ~ Pr. 02-41 for multi-function output selection Resistive load: 3 A (N.O.) / 250 V _{AC} 5 A (N.O.) / 30 V _{DC} Inductive load (COS 0.4) 1.2 A (N.O.) / 250 V _{AC} 2.0 A (N.O.) / 30 V _{DC} It is used to output each monitor signal, such as for drive in operation, frequency attained or overload indication

Analog I/O Extension Card

- EMV-A22A

	Terminals	Descriptions
	AVI10 AVI11	Refer to Pr. 14-00 ~ Pr. 14-01 for function selection (input), and Pr. 14-18 ~ Pr. 14-19 for mode selection Two sets of AVI port for AVI or ACI switch: SSW3 (AVI10) and SSW4 (AVI11) AVI: Input 0 ~ 10 V ACI: Input 0 ~ 20 mA / 4 ~ 20 mA
	AFM10 AFM11	Refer to Pr. 14-12 ~ Pr. 14-13 for function selection (output), and Pr. 14-36 ~ Pr. 14-37 for mode selection Two sets of AFM port for AVO or ACO switch: SSW1 (AFM10) and SSW2 (AFM11) AVO: Output 0 ~ 10 V ACO: Output 0 ~ 20.0 mA / 4.0 ~ 20.0 mA
	ACM	Analog signal common terminal

I/O Extension Card

- EMV-D42A

	Terminals	Descriptions
	COM	Common for multi-function input terminals Select SINK (NPN) / SOURCE (PNP) in J1 jumper / external power supply
	MI10 ~ MI13	Refer to Pr. 02-26 ~ Pr. 02-29 to program the multi-function inputs MI10 ~ MI13 Internal power is applied from terminal E24: +24 V _{DC} ± 5% 200 mA, 5 W External power +24 V _{DC} : Max. voltage 30 V _{DC} , Min. voltage 19 V _{DC} , 30 W ON: the activation current is 6.5 mA; OFF: leakage current tolerance is 10 μA
	MO10 ~ MO11	Multi-function output terminals (photocoupler) Duty-cycle: 50%; Max. output frequency: 100 Hz Max. current: 50 mA; Max. voltage: 48 V _{DC}
	MXM	Common for multi-function output terminals MO10, MO11 (photocoupler) Max. 48 V _{DC} 50 mA

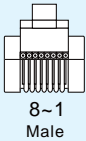
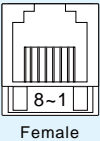

CANopen Communication Card

EMC-COP01

  	RJ45 Pin	Pin Name	Definition
	1	CAN_H	CAN_H bus line (dominant high)
	2	CAN_L	CAN_L bus line (dominant low)
	3	CAN_GND	Ground / 0V / V-
	6	CAN_GND	Ground / 0V / V-

EtherNet/IP, Modbus TCP Communication Card

CMC-EIP01/CMC-EIP02

 	Features	
	<ul style="list-style-type: none"> Supports max. 32 words input and 32 words output of I/O connection User-defined parameter mapping 	<ul style="list-style-type: none"> IP Filter, basic firewall function Supports DLR ring nodes *Applicable to CMC-EIP02

Network Interface			
Network Protocol	EtherNet/IP, Modbus TCP	Interface	RJ45
Transmission Speed	10/100 Mbps	Number of Ports	1 (CMC-EIP01) / 2 (CMC-EIP02)
Transmission Method	IO Connection / Explicit message	Transmission Cable	Category 5e shielding
Transmission Distance	100m, extension is allowed via switch		

PROFINET Communication Card

CMC-PN01

	Features	
	<ul style="list-style-type: none"> Supports PROFINET IO device Supports synchronous data transmission and non-synchronous parameter access Provides GSDML file for PROFINET communication 	

Network Interface			
Interface	RJ45	Transmission Cable	Category 5e shielding 100 M
Number of Ports	2 Ports	Transmission Speed	10/100 Mbps Auto-detect
Transmission Method	IEEE 802.3	Network Protocol	PROFINET

Accessories

PROFIBUS DP Card

▪ CMC-PD01

	Features	
	<ul style="list-style-type: none"> • Supports PZD control data exchange • Supports PKW polling AC motor drive parameters • Supports user diagnosis function 	<ul style="list-style-type: none"> • Supports Remote I/O • Auto-detects baud rates; supports Max. 12 Mbps

PROFIBUS DP Connector		Communication	
Interface	DB9 connector	Message Type	Cyclic data exchange
Transmission Method	High-speed RS-485	Module Name	CMC-PD01
Transmission Cable	Shielded twisted pair cable	GSD Document	DELA08DB.GSD
Electrical Isolation	500 V _{DC}	Company ID	08DB (HEX)
Serial Transmission Speed Supported (Auto-Detection)	9.6 Kbps; 19.2 Kbps; 93.75 Kbps; 187.5 Kbps; 500 Kbps; 1.5 Mbps; 3 Mbps; 6 Mbps; 12 Mbps (bits per second)		

DeviceNet Communication Card

▪ CMC-DN01

	Features	
	<ul style="list-style-type: none"> • Based on the high-speed communication interface of Delta HSSP protocol, able to conduct immediate control of an AC motor drive • Supports Group 2 only connection and polling I/O data exchange • For I/O mapping, supports Max. 32 words of input, 32 words of output, and Remote I/O • Node address and serial transmission speed can be set up on AC motor drive • Power supplied from AC motor drive 	

DeviceNet Connector		DeviceNet Connector	
Interface	5-Pin 5.08 mm pluggable connector	Interface	50-Pin communication terminal
Transmission Method	CAN	Transmission Method	SPI communication
Transmission Cable	Shielded twisted pair cable (with 2 power cables)	Terminal Function	1. Communicating with AC motor drive 2. Transmitting power supply from AC motor drive
Transmission Speed	125 Kbps, 250 Kbps, 500 Kbps and extendable serial transmission speed mode	Communication Protocol	Delta HSSP protocol
Network Protocol	DeviceNet protocol		

Delta Standard Fieldbus Cables

Delta Cables	Part Number	Description	Length
CANopen Cable / Digital Keypad RJ45 Extension Cable	UC-CMC003-01A	CANopen cable, RJ45 connector	0.3 m
	UC-CMC005-01A	CANopen cable, RJ45 connector	0.5 m
	UC-CMC010-01A	CANopen cable, RJ45 connector	1 m
	UC-CMC015-01A	CANopen cable, RJ45 connector	1.5 m
	UC-CMC020-01A	CANopen cable, RJ45 connector	2 m
	UC-CMC030-01A	CANopen cable, RJ45 connector	3 m
	UC-CMC050-01A	CANopen cable, RJ45 connector	5 m
	UC-CMC100-01A	CANopen cable, RJ45 connector	10 m
	UC-CMC200-01A	CANopen cable, RJ45 connector	20 m
DeviceNet Cable	UC-DN01Z-01A	DeviceNet cable	305 m
	UC-DN01Z-02A	DeviceNet cable	305 m
EtherNet Cable	UC-EMC003-02C	EtherNet cable, Shielding	0.3 m
	UC-EMC005-02C	EtherNet cable, Shielding	0.5 m
	UC-EMC010-02C	EtherNet cable, Shielding	1 m
	UC-EMC020-02C	EtherNet cable, Shielding	2 m
	UC-EMC050-02C	EtherNet cable, Shielding	5 m
	UC-EMC100-02C	EtherNet cable, Shielding	10 m
	UC-EMC200-02C	EtherNet cable, Shielding	20 m

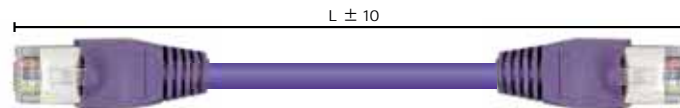

CANopen / DeviceNet TAP Breakout Boxes

Model	Description
TAP-CN01	1 in 2 out, built-in 121Ω terminal resistor
TAP-CN02	1 in 4 out, built-in 121Ω terminal resistor
TAP-CN03	1 in 4 out, RJ45 connector, built-in 121Ω terminal resistor

Unit: mm [inch]

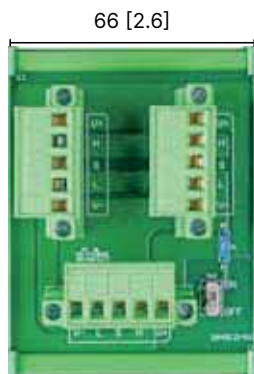

TAP-CN01

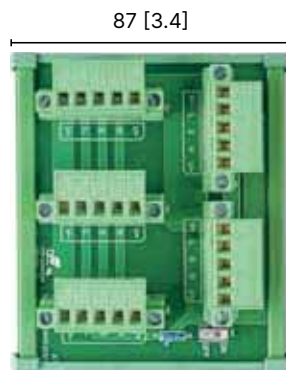

TAP-CN02



TAP-CN03

Ordering Information

Frame Size	Power Range	Models		
		Without EMC UL open type LED keypad	With EMC C3 UL type 1 LCD keypad	With EMC C2 UL type 1 LCD keypad
Frame AWW	460 V: 0.75 ~ 4 kW	Frame A1 VFD3A0VP43ANTAA VFD4A2VP43ANTAA VFD5A6VP43ANTAA VFD7A2VP43ANTAA VFD011VP43ANTAA	Frame A2 VFD3A0VP43BFTAA VFD4A2VP43BFTAA VFD5A6VP43BFTAA VFD7A2VP43BFTAA VFD011VP43BFTAA	
Frame B	460 V: 5.5 ~ 7.5 kW	Frame B1 VFD013VP43ANTAA VFD018VP43ANTAA	Frame B2 VFD013VP43BFTAA VFD018VP43BFTAA	
Frame C	460 V: 11 ~ 18.5 kW	Frame C1 VFD025VP43ANTAA VFD032VP43ANTAA VFD038VP43ANTAA	Frame C2 VFD025VP43BFTAA VFD032VP43BFTAA VFD038VP43BFTAA	
Frame D	460 V: 22 ~ 30 kW	Frame D1 VFD045VP43ANTCA VFD062VP43ANTCA	Frame D2 VFD045VP43BFTCA VFD062VP43BFTCA	Frame D2 VFD045VP43BSTCA VFD062VP43BSTCA
Frame E	460 V: 37 ~ 45 kW	Frame E1 VFD073VP43ANTCA VFD090VP43ANTCA	Frame E2 VFD073VP43BFTCA VFD090VP43BFTCA	Frame E2 VFD073VP43BSTCA VFD090VP43BSTCA
Frame F	460 V: 55 kW	Frame F1 VFD110VP43AFTCA	Frame F2 VFD110VP43BFTCA	Frame F2 VFD110VP43BSTCA
Frame G	460 V: 75 kW	Frame G1 VFD150VP43AFTCA	Frame G2 VFD150VP43BFTCA	Frame G2 VFD150VP43BSTCA
Frame H	460 V: 90 ~ 110 kW	Frame H1 VFD180VP43AFTCA VFD220VP43AFTCA	Frame H2 VFD180VP43BFTCA VFD220VP43BFTCA	Frame H2 VFD180VP43BSTCA VFD220VP43BSTCA
Frame I	460 V: 132 ~ 160 kW	Frame I1 VFD260VP43AFTCA VFD310VP43AFTCA	Frame I2 VFD260VP43BFTCA VFD310VP43BFTCA	Frame I2 VFD260VP43BSTCA VFD310VP43BSTCA
Frame J	460 V: 185 ~ 200 kW	Frame J1 VFD370VP43AFTCA VFD395VP43AFTCA	Frame J2 VFD370VP43BFTCA VFD395VP43BFTCA	Frame J2 VFD370VP43BSTCA VFD395VP43BSTCA
Frame K	460 V: 220 ~ 250 kW	Frame K1 VFD460VP43AFTCA VFD485VP43AFTCA	Frame K2 VFD460VP43BFTCA VFD485VP43BFTCA	Frame K2 VFD460VP43BSTCA VFD485VP43BSTCA
Frame L (Chassis IP00 model)	460 V: 280 ~ 400 kW		Frame L2 VFD530VP43SHTCA VFD616VP43SHTCA VFD683VP43SHTCA VFD770VP43SHTCA	
Frame M (Chassis IP00 model)	460 V: 450 ~ 630 kW		Frame M2 VFD866VP43SHTCA VFD930VP43SHTCA VFD1K1VP43SHTCA VFD1K2VP43SHTCA	

All models with suffix N are models without keypad, for example: VFD3A0VP43ANTAA → VFD3A0VP43ANTAN

Model Name Explanation

Example	[1] VFD	[2] 3A0	[3] VP	[4] 43	[5] A	[6] N	[7] T	[8] A	[9] A
Definition			Description						
[1]	Product name	AC Motor Drive							
[2]	Current specification	Continuous current (I_{CON}) Note: Refer to Specifications in the user manual for detailed current spec.							
[3]	Series	VP3000							
[4]	Input voltage	43 = 460 V three-phase							
[5]	IP protection ratings	A = IP20/UL Open type/Wall-mount B = IP20/Type 1/Wall-mount S = IP00/UL Open type/Chassis							
[6]	EMC filter	N = No built-in EMC Filter F = EMC C3 category S = EMC C2 category H = EMC C3 category of chassis							
[7]	Safety function	T = Built-in STO (SIL3)							
[8]	Special specification	A = No built-in DC choke C = Lower harmonic (THDi min. 35%)							
[9]	Digital keypad	A = Built-in digital keypad N = Without digital keypad Note: 1. For IP20 / UL Open Type models, accompanied with a LED digital keypad KPV-CE02 2. For IP20 / Type 1 models, accompanied with a LCD digital keypad KPV-CC01							



Smarter. Greener. Together.

Industrial Automation Headquarters

Taiwan: Delta Electronics, Inc.

Taoyuan Technology Center
No.18, Xinglong Rd., Taoyuan District,
Taoyuan City 33068, Taiwan
TEL: +886-3-362-6301 / FAX: +886-3-371-6301

Asia

China: Delta Electronics (Shanghai) Co., Ltd.

No.182 Minyu Rd., Pudong Shanghai, P.R.C.
Post code : 201209
TEL: +86-21-6872-3988 / FAX: +86-21-6872-3996
Customer Service: 400-820-9595

Japan: Delta Electronics (Japan), Inc.

Industrial Automation Sales Department
2-1-14 Shibadaimon, Minato-ku
Tokyo, Japan 105-0012
TEL: +81-3-5733-1155 / FAX: +81-3-5733-1255

Korea: Delta Electronics (Korea), Inc.

1511, 219, Gasan Digital 1-Ro., Geumcheon-gu,
Seoul, 08501 South Korea
TEL: +82-2-515-5305 / FAX: +82-2-515-5302

Singapore: Delta Energy Systems (Singapore) Pte Ltd.

4 Kaki Bukit Avenue 1, #05-04, Singapore 417939
TEL: +65-6747-5155 / FAX: +65-6744-9228

India: Delta Electronics (India) Pvt. Ltd.

Plot No.43, Sector 35, HSIIDC Gurgaon,
PIN 122001, Haryana, India
TEL: +91-124-4874900 / FAX: +91-124-4874945

Thailand: Delta Electronics (Thailand) PCL.

909 Soi 9, Moo 4, Bangpoo Industrial Estate (E.P.Z),
Pattana 1 Rd., T.Phraksa, A.Muang,
Samutprakarn 10280, Thailand
TEL: +66-2709-2800 / FAX: +66-2709-2827

Australia: Delta Electronics (Australia) Pty Ltd.

Unit 2, Building A, 18-24 Ricketts Road,
Mount Waverley, Victoria 3149 Australia
Mail: IA.au@deltaww.com
TEL: +61-1300-335-823 / +61-3-9543-3720

Americas

USA: Delta Electronics (Americas) Ltd.

5101 Davis Drive, Research Triangle Park, NC 27709, U.S.A.
TEL: +1-919-767-3813 / FAX: +1-919-767-3969

Brazil: Delta Electronics Brazil Ltd.

Estrada Velha Rio-São Paulo, 5300 Eugênio de
Melo - São José dos Campos CEP: 12247-004 - SP - Brazil
TEL: +55-12-3932-2300 / FAX: +55-12-3932-237

Mexico: Delta Electronics International Mexico S.A. de C.V.

Gustavo Baz No. 309 Edificio E PB 103
Colonia La Loma, CP 54060
Tlalnepantla, Estado de México
TEL: +52-55-3603-9200

EMEA

EMEA Headquarters: Delta Electronics (Netherlands) B.V.

Sales: Sales.IA.EMEA@deltaww.com
Marketing: Marketing.IA.EMEA@deltaww.com
Technical Support: iatechnicalsupport@deltaww.com
Customer Support: Customer-Support@deltaww.com
Service: Service.IA.emea@deltaww.com
TEL: +31(0)40 800 3900

BENELUX: Delta Electronics (Netherlands) B.V.

Automotive Campus 260, 5708 JZ Helmond, The Netherlands
Mail: Sales.IA.Benelux@deltaww.com
TEL: +31(0)40 800 3900

DACH: Delta Electronics (Netherlands) B.V.

Coesterweg 45, D-59494 Soest, Germany
Mail: Sales.IA.DACH@deltaww.com
TEL: +49 2921 987 238

France: Delta Electronics (France) S.A.

ZI du bois Challand 2, 15 rue des Pyrénées,
Lisses, 91090 Evry Cedex, France
Mail: Sales.IA.FR@deltaww.com
TEL: +33(0)1 69 77 82 60

Iberia: Delta Electronics Solutions (Spain) S.L.U

Ctra. De Villaverde a Vallecas, 265 1º Dcha Ed.
Hormigueras – P.I. de Vallecas 28031 Madrid
TEL: +34(0)91 223 74 20
Carrer Llacuna 166, 08018 Barcelona, Spain
Mail: Sales.IA.Iberia@deltaww.com

Italy: Delta Electronics (Italy) S.r.l.

Via Meda 2-22060 Novedrate(CO)
Piazza Grazioli 18 00186 Roma Italy
Mail: Sales.IA.Italy@deltaww.com
TEL: +39 039 8900365

Russia: Delta Energy System LLC

Vereyskaya Plaza II, office 112 Vereyskaya str.
17 121357 Moscow Russia
Mail: Sales.IA.RU@deltaww.com
TEL: +7 495 644 3240

Turkey: Delta Greentech Elektronik San. Ltd. Sti. (Turkey)

Şerifali Mah. Hendem Cad. Kule Sok. No:16-A
34775 Ümraniye – İstanbul
Mail: Sales.IA.Turkey@deltaww.com
TEL: + 90 216 499 9910

MEA: Eltek Dubai (Eltek MEA DMCC)

OFFICE 2504, 25th Floor, Saba Tower 1,
Jumeirah Lakes Towers, Dubai, UAE
Mail: Sales.IA.MEA@deltaww.com
TEL: +971(0)4 2690148