

Delta Ventilation Fans

VFB530KTH

Features

- ▲ High Efficiency Brushless DC Motor
- ▲ Low Power Consumption
- ▲ Low Noise Design
- ▲ Long Life Ball Bearings
- ▲ Soft Start Control
- ▲ Easy Installation & Maintenance
- ▲ High Air Flow



VFB530KTH

Application

Bathroom & Bedroom / Dining Room & Living Room /
Meeting Room / Office

Dimensions unit: mm

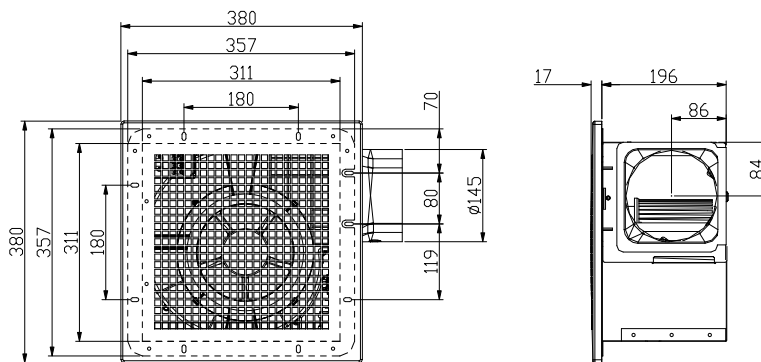

P&Q Curve

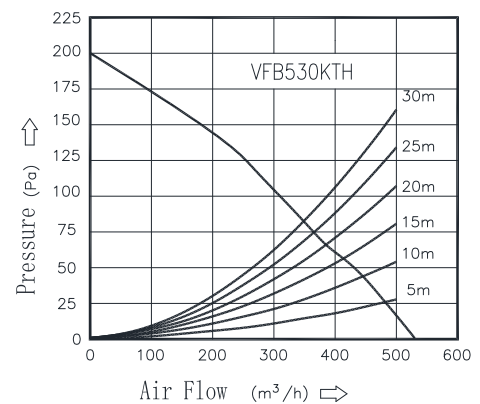

Specifications

Model	Grille Size	Install Size	Duct Size	Weight	Nominal Voltage	Input Power	Maximum Airflow	Maximum Air Pressure	Noise	Remark		
PART NO.	mm	mm	mm	kg	VAC	Watt	m³/h	CFM	Pa	inAq	dB-A	---
VFB530KTH	380 X 380	320 X 320	150	5.7	220/50	37	530	312	200	0.8	41	

* The max. air flow is measured in free air; the max. air pressure is measured at zero air flow.

* Noise is measured in semi-anechoic chamber in free air, one meter from intake, right and left side, 3 microphones to average.

* All readings are typical values at rated voltage.

* Specifications are subject to change without notice.