

## Delta Ventilation Fans

### VFB430GTH

#### Features

- ▲ High Efficiency Brushless DC Motor
- ▲ Low Power Consumption
- ▲ Low Noise Design
- ▲ Long Life Ball Bearings
- ▲ Soft Start Control
- ▲ Easy Installation & Maintenance
- ▲ High Air Flow



VFB430GTH

#### Application

Bathroom & Bedroom / Dining Room & Living Room /  
Meeting Room / Office

#### Dimensions unit: mm

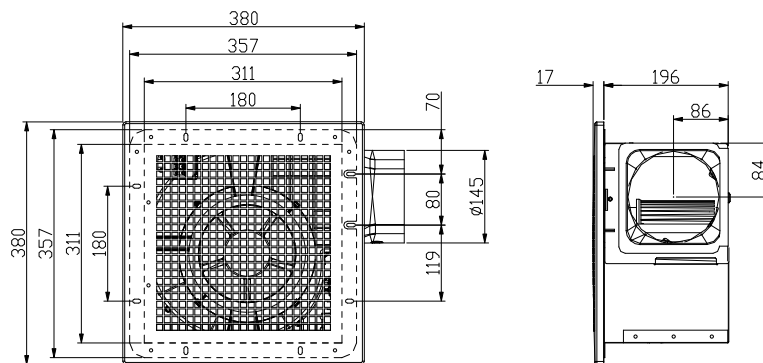

#### P&Q Curve

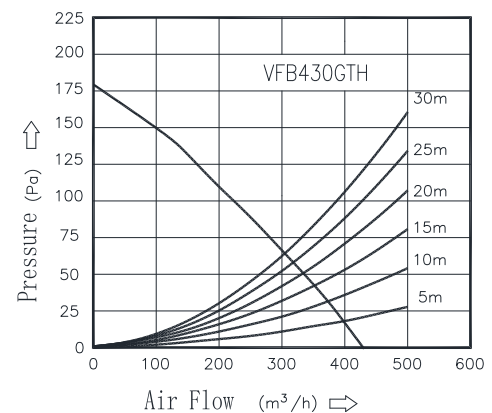

#### Specifications

Model	Grille Size	Install Size	Duct Size	Weight	Nominal Voltage	Input Power	Maximum Airflow		Maximum Air Pressure		Noise	Remark
PART NO.	mm	mm	mm	kg	VAC	Watt	m³/h	CFM	Pa	inAq	dB-A	---
VFB430GTH	380 X 380	320 X 320	150	5.7	220/50	17.5	430	253	180	0.72	36	

\* The max. air flow is measured in free air; the max. air pressure is measured at zero air flow.

\* Noise is measured in semi-anechoic chamber in free air, one meter from intake, right and left side, 3 microphones to average.

\* All readings are typical values at rated voltage.

\* Specifications are subject to change without notice.