



NovoConnect™ B360

Wireless Presentation & Collaboration System



User Manual

Version 1.2.1

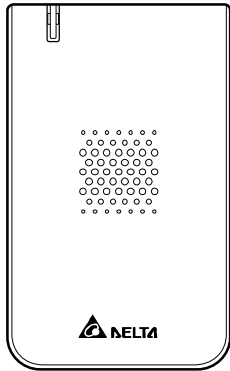
Table of Contents

1. GETTING STARTED.....	4
1.1 Package contents	4
1.2 Setting up your NovoConnect B360 device	5
1.2.1 How to connect your NovoConnect B360 device.....	5
1.2.2 The NovoConnect Home Screen	6
1.3 Software download and installation.....	7
2. WI-FI SETUP	10
2.1 Hotspot Mode.....	10
2.2 Client Mode	11
3. MAKING A PRESENTATION.....	12
3.1 Presenting with Windows and Mac PC	12
3.1.1 Step 1: Presentation software configuration.....	13
3.1.2 Step 2: Connect to your B360 device.....	14
3.1.3 Step 3: Make a presentation	15
3.1.4 Step 4: Presentation management.....	15
3.1.4.1 Role assignment.....	15
3.1.4.2 Role change, screen preview, and four-way split screen	17
3.1.4.3 Pause, resume, and disconnect	18
3.2 Presenting with iOS tablet (iPad)	20
3.2.1 Step 1: Connect to your B360 device.....	20
3.2.1.1 Connect to your B360 device automatically via QR Code	21
3.2.1.2 Connect to your B360 device manually.....	22
3.2.3 Step 3: Make a presentation	25
3.2.3.1 Presenting an image	26
3.2.3.2 Presenting a document (local storage)	28
3.2.3.2 Presenting a document (with Dropbox).....	29
3.2.3.3 Presenting with a browser	32
3.2.3.4 Annotation	34
3.2.4 Step 4: Presentation Management	35
3.2.4.1 Role assignment.....	36

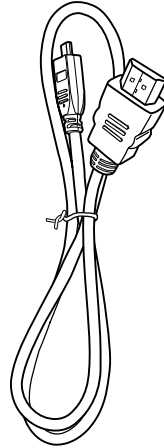
3.2.4.2 Role change, screen preview, and four-way split screen	37
3.2.4.3 Pause, resume, and disconnect	40
3.2.4.4 Reset	41
3.3 Presenting with Android Tablet	43
3.3.1 Step 1: Connect to your B360 Device	43
3.3.1.1 Connect to your B360 device automatically via QR Code	44
3.3.1.2 Connect to your B360 device manually.....	45
3.3.2 Step 2: Make a presentation	48
3.3.2.1 Presenting an image	48
3.3.2.2 Presenting a document (local storage)	50
3.3.2.3 Presenting a document (with Dropbox)	52
3.3.2.4 Presenting a document (with a browser).....	54
3.3.2.5 Annotation	56
3.3.3 Step 3: Presentation management.....	57
3.3.3.1 Role assignment.....	57
3.3.3.2 Role change, screen preview, and four-way split screen	59
3.3.3.3 Pause, resume, and disconnect	61
3.3.3.4 Reset and rename local device.....	62
3.4 Presenting with the NovoConnect B360 device.....	63
4. B360 CONFIGURATION	66
5. SPECIFICATIONS.....	71
6. TROUBLESHOOTING.....	72
7. SAFETY INFORMATION.....	74
8. COPYRIGHT INFORMATION.....	75
9. INDEX.....	76

1. Getting Started

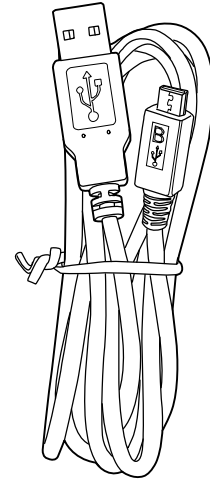
1.1 Package contents



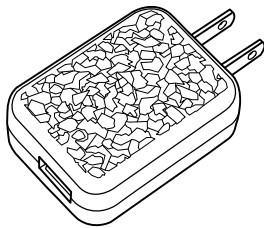
(a) NovoConnect B360 main unit



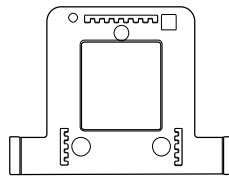
(b) Micro-HDMI-to-HDMI cable



(c) Micro-USB-to-USB power cable

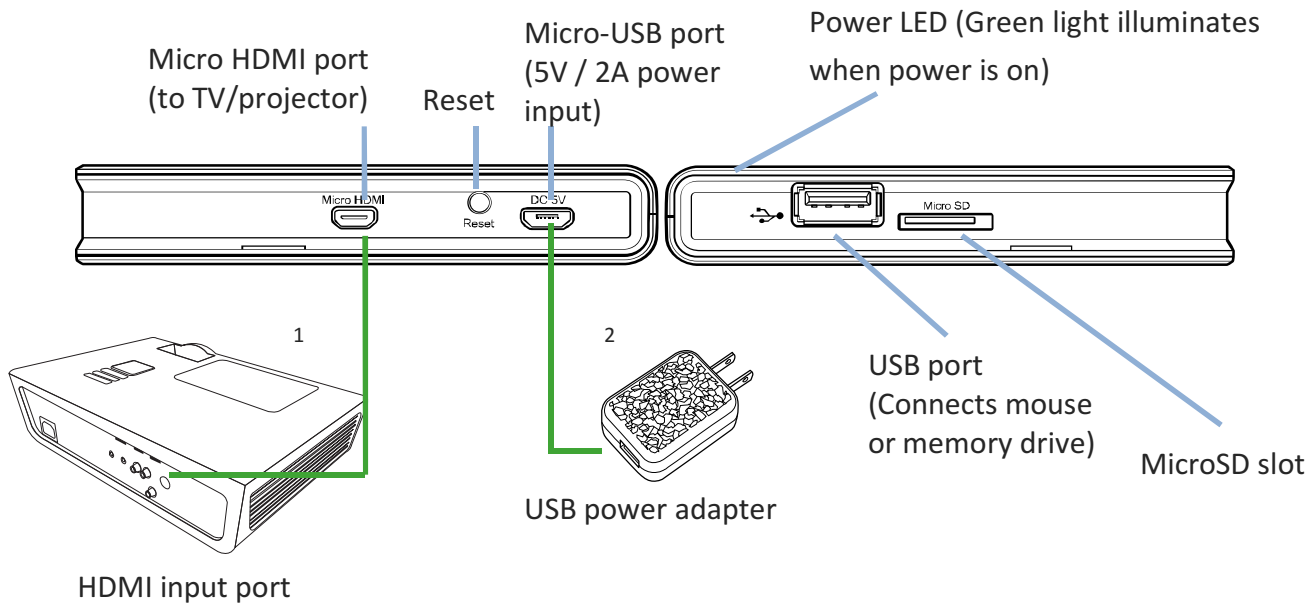


(d) USB power adapter



(e) NovoConnect Mount

1.2 Setting up your NovoConnect B360 device



1.2.1 How to connect your NovoConnect B360 device

1. Video/Audio connection: Connect the Micro HDMI port to the TV/projector's HDMI input port using the Micro-HDMI-to-HDMI cable (item (b) in "Package Contents.")
2. Power: Connect the Micro-USB port to a power outlet using the Micro-USB-to-USB power cable and the USB power adapter (items (c) and (d) in "Package Contents.")
3. At this stage the NovoConnect B360's green LED power indicator should be illuminated. (See above illustration for Power LED location.)

Note: In this manual, your NovoConnect B360 will also be referred to as B360 for short.

Note: You may connect an optional USB mouse or a memory drive to the USB port.

Note: The microSD slot supports microSD cards up to 32 GB in, FAT32 and NTFS file formats.

1.2.2 The NovoConnect Home Screen

The NovoConnect B360 device will power up with the below display after steps 1 and 2 listed above. This display is referred to as the “NovoConnect home screen” or just the “home screen” in this document. The home screen is generated by the presentation management software, in the B360 device, which is also known as the *remote viewer*.



1 Presentation setup

The default Wi-Fi mode for your B360 is Hotspot Mode. To connect your computer or tablet device, enable Wi-Fi in the device setting. Search for and connect to the SSID shown in this step (e.g. NVC_39FC7).

2 Software installation

Windows/Mac Users: Enter the URL displayed on the home screen under “Desktop Streamer” into your web browser and follow the instructions in the next section.

iPad/Android Users: Follow the instructions in the next section.

3 Connect

Windows/Mac Users: Launch the installed NovoConnect *Desktop Streamer* application and enter the URL (and PIN if required) shown on the home screen in this step.

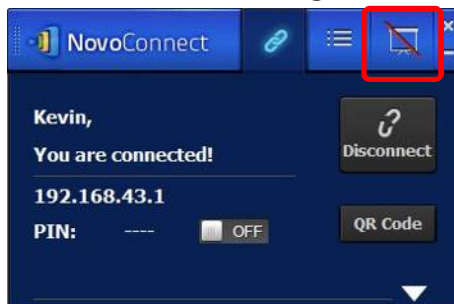
iPad/Android Devices: Scan the QR code on the bottom right corner of the NovoConnect screen or manually configure your tablet by entering the IP address (and PIN if required) into your *NovoPresenter* and connect.

4 Select the Application Edition (optional)

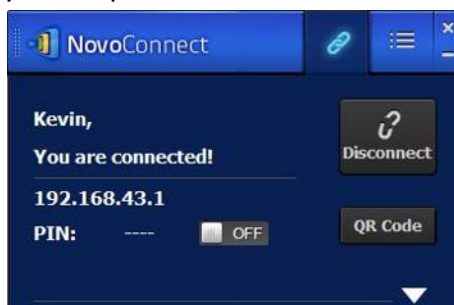
Connect a USB mouse to your B360. Click the on-screen edition display area to set your NovoConnect to either *Corporate Edition* or *Education Edition*.

The main differences between these two editions are as follows:

Corporate Edition: During a presentation, the *host* must obtain permission from *participants* for screen preview. After connecting to the NovoConnect B360 device, each user has a screen preview control tab. For more information on the screen preview function, refer to the **Presentation Management** section for your respective device.



Education Edition: During a presentation, the *host* can preview the screen of any *participant* without needing to first obtain permission. After connecting to the NovoConnect B360 device, each use will not have a screen preview control tab. For more information on the screen preview function refer to the **Presentation Management** section for your respective device.



Note: This manual primarily references the Corporate Edition for instructional examples. Special notes will accompany instructions that are specific to the Education Edition.

1.3 Software download and installation

The NovoConnect B360 device supports connections of up to 64 concurrent *participants* across a mix of PC and tablet devices. Each *participant's* device will need to set up a connection through the presentation application, *Remote Viewer*, residing on the B360 to make a presentation. You will need to download and install the following application software:

On Windows PC - [NovoConnect Desktop Streamer](#)




On Mac PC - [NovoConnect Desktop Streamer](#)

On iOS tablet – [NovoPresenter](#)

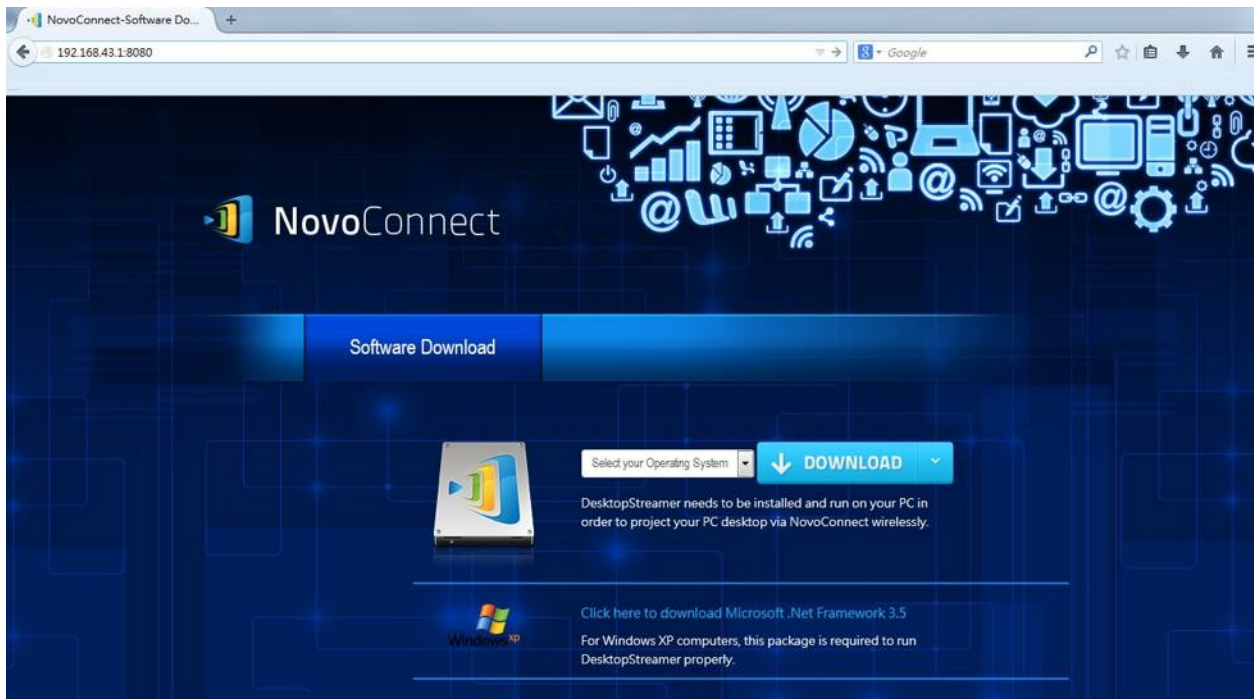
On Android tablet – *NovoPresenter*

Note: Throughout the document, these four presentation applications and the *B360 Remote Viewer* software are highlighted in *italics* type.

Downloading the presentation software for Windows PC and Mac PC

Enable Wi-Fi on the computer. Click the network icon , , or . Select the B360 SSID on the NovoConnect home screen (for example, NVC_39FC7) and click Connect or Join. Ignore all security warnings.

Launch your preferred Web browser on your PC and enter the URL displayed on the NovoConnect home screen. For the example home screen shown above, you would enter <http://192.168.43.1:8080> into the address line of the browser. The following screen will be displayed on your browser.



Select the appropriate operating system from the drop-down menu and then click the **DOWNLOAD** button to download the NovoConnect *Desktop Streamer* software to your PC.

Installing the application software for Windows PC and Mac PC

Launch either *Desktop_Streamers_Setup_Windows.exe* (for MS Windows based computers) or *Desktop_Streamers_Setup_Mac.exe* (for Macintosh computers) by double clicking the downloaded file on your computer. Follow the installation instructions on the PC to complete the installation and allow all security permissions for NovoConnect *Desktop Streamer* and all of its subcomponents.

The computer is now ready to make a wireless presentation with your B360.

Downloading and installing the presentation software for Android and iOS tablet devices

On iOS tablets, the iOS version of *NovoPresenter* is required. You can download and install it from the Apple App Store.

On Android tablets, the Android version of *NovoPresenter* is required. You can download and install it from the Google Playstore.

Once you have downloaded and installed the presentation software, you are ready to make a wireless presentation from your tablet device.

2. Wi-Fi Setup

Depending on where your presentation content is located and the number of *participants* in the presentation, you may select one of the following Wi-Fi modes from the NovoConnect home screen.

- A) Client Mode – for when your content is residing in a private cloud or the Internet cloud, and the number of *participants* is more than eight
- B) Hotspot Mode – for when your content is residing on your PC or tablet, and the number of *participants* is eight or fewer
- C) Neither – for when your content is residing on your microSD card



The NovoConnect B360 defaults to start up in Wi-Fi Hotspot mode, which is the most direct way to create a wireless presentation without using a Wi-Fi access point (AP). If this is your preferred mode, go to section 2.1 “Hotspot Mode” for steps on making a presentation.


If you would prefer to make your presentation through a Wi-Fi network, please refer to section 2.2 “Client Mode” in this chapter.

2.1 Hotspot Mode

Right out of the box, NovoConnect’s Wi-Fi is set to function as a Wi-Fi Hotspot and will stay in this configuration until you alter it. The default SSID for the Wi-Fi hotspot is “NVC_XXXXX”, where “XXXXX” is a device-generated string of characters and numbers. A USB mouse is required for the following steps.

If you alter your settings and then choose to revert to Hotspot Mode, on the NovoConnect home screen, select **WiFi-> Hotspot Mode->Apply**.

For a PC to connect to the B360 Hotspot, click the network icon  or  on task bar. Select the SSID of the NovoConnect B360 device shown on the home screen (for example, NVC_DC9AB) and click **Connect**.

For a Mac to connect to the B360 hotspot, click the network icon . Select the SSID of the NovoConnect B360 device shown on the home screen (for example, NVC_DC9AB) and click **Join**. Ignore any security warnings.

For a tablet to connect to the B360 hotspot, enable Wi-Fi and go to the Wi-Fi AP list. Select the SSID of the NovoConnect B360 device shown on the home screen (for example, NVC_DC9AB).



Note: When operating in Hotspot Mode, all participating presentation devices must be connected to the same NovoConnect B360 Wi-Fi hotspot.


Note: Up to eight simultaneous *participants* are supported in Hotspot Mode.

2.2 Client Mode

In this mode, the B360 device functions as a Wi-Fi client and a Wi-Fi AP is needed for network connectivity. A mouse is required for the following steps.

On the home screen of the NovoConnect, first select **WiFi->Normal Mode-> Config->Wireless & Networks-> Wi-Fi (ON)**, and then select the desired Wi-Fi AP SSID (the name associate with the Wi-Fi network). Enter a password if prompted.

To connect a PC to the Wi-Fi AP, click the network icon  or . Select the desired Wi-Fi AP SSID. Enter a password if prompted.

To connect a Mac to the Wi-Fi AP, click the network icon . Select the desired Wi-Fi AP SSID and click **Join**. Enter a password if prompted.

To connect a tablet to the Wi-Fi AP, enable Wi-Fi and go to the Wi-Fi AP list. Select the desired Wi-Fi AP SSID. Enter a password if prompted.


3. Making a Presentation

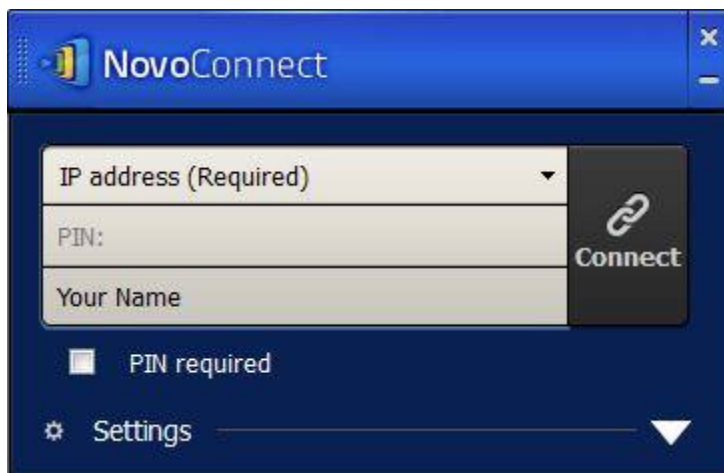
The NovoConnect B360 device supports up to 64 concurrent *participants* across a mix of PC and tablet devices. To make a presentation, each *participant's* device will need to connect to the B360 and join the presentation group hosted by the B360. There are four key features that help facilitate smooth collaboration and coordination of presentations using the NovoConnect:

- 1) A *participant* list is included with the individuals' roles indicated by clear graphical representation.
- 2) A specific capability is defined for each role.
- 3) The split screen for simultaneous presentation of multiple *participants*.
- 4) Annotation tools allow participants to highlight, draw or make notations on the display screen.

3.1 Presenting with Windows and Mac PC

Launch Presentation Application


Launch the *NovoConnect Desktop Streamer* Application by double clicking the  icon. Once launched, the *NovoConnect Desktop Streamer* will appear as pictured in the image below.

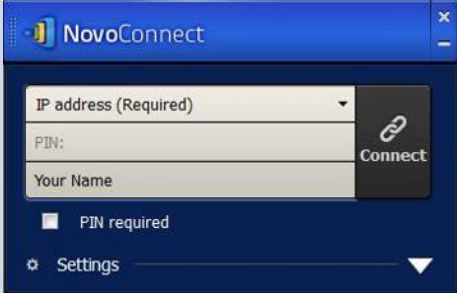







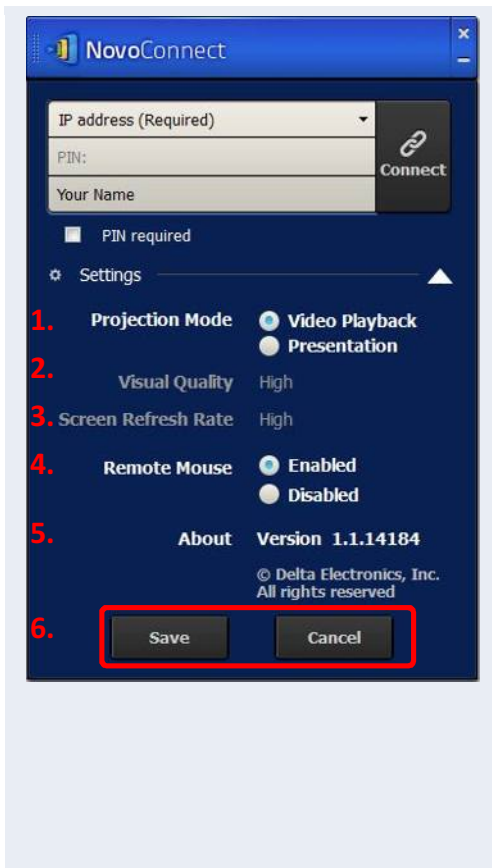
To make a presentation, follow the steps listed below:

- Step 1: Configure the presentation application
- Step 2: Connect to your B360 device
- Step 3: Make a presentation
- Step 4: Manage the presentation

3.1.1 Step 1: Presentation software configuration

Click the connection tab  and access the configuration options of *NovoConnect Desktop Streamer* as shown below.



Function	Description
	<p>Configure the <i>NovoConnect Desktop Streamer</i> Application.</p>
	<p>Manually enter the IP address shown on the NovoConnect home screen, or select an IP address entry from the drop-down menu that matches the IP address shown on the NovoConnect home screen.</p>
	<p>(Optional) Manually enter a name for this computer to be viewed in the presentation group among other <i>participants</i>. Example: Kevin. (Note: If a name is not entered in this field, the default name for your device will be used.)</p>
	<p>If PIN is required for a presentation group, check the “PIN required” box and enter the four-digit PIN shown on the home screen.</p>
	<p>Click  to expand the Settings tab to access additional settings options.</p>

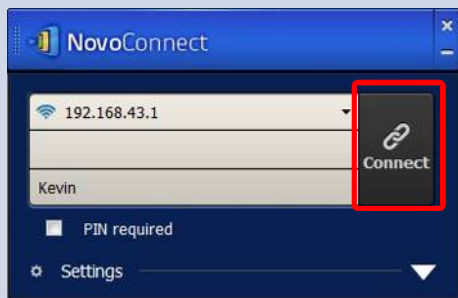

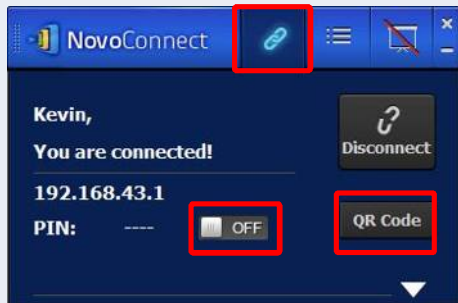



1. **Projection Mode:**
Video Playback: Select this option for a higher frame rate screen mirroring and to turn on audio transmission.
Presentation: Select this option for document presentation or browser content presentation. The audio will be automatically set to off. Two additional drop-down configurations, *Visual Quality* and *Screen Refresh Rate*, will be enabled.
2. **Visual Quality:**
High: This setting yields the best visual quality but has the most latency and may result in longer video delay.
Normal: This setting yields the normal visual quality with the normal CPU consumption.
3. **Screen Refresh Rate:**
High: This setting yields the enhanced visual quality but results in higher CPU consumption.
Normal: This setting yields the normal visual quality with the normal CPU consumption.
4. **Remote Mouse:**
 Supports mouse event back-channeled from the B360 device to your desktop.
5. **About:**
 Software version number of your NovoConnect *Desktop Streamer*.
6. **Save and Cancel buttons:** You can save your configuration for future presentations.

3.1.2 Step 2: Connect to your B360 device

Once you are done configuring your NovoConnect *Desktop Streamer*, you are ready to start or join a presentation group with your B360.

(Note: *Education Edition* does not have the screen preview control tab  or the  symbol.)

Function	Description
	<p>Connect to your B360 device.</p> <p>Click the  button. If you are the first <i>participant</i>, this will start a presentation group on your B360. If you are not the first <i>participant</i>, you will be joining a presentation group.</p>
	<p>After your <i>Desktop Streamer</i> is connected successfully to your B360, you will see the connection tab light up .</p> <p>If you are the first <i>participant</i>, you will see that your PC's on-screen display is wirelessly mirrored on your projector or TV display. You can also slide the PIN requirement switch to OFF or ON to enable the use of an access PIN code for the presentation group.</p>



The image shows a software window titled "NovoConnect Session Info". It features a large QR code in the center. Below the QR code, the following session information is displayed: IP: 192.168.43.1, PIN: ----, and SSID: NVC_39FC7. To the right of the window, there is a text block explaining that the first participant can allow others to join via QR code by clicking a "QR Code" button to display the QR code and session information windows for others to quickly connect to their B360.

Please note that your PC screen resolutions may change to match projector resolution. After disconnecting from the NovoConnect device, the original screen resolution will be restored. This will occur for all PCs in the same presentation group.

3.1.3 Step 3: Make a presentation

Once you have started/joined a presentation group you can make a presentation with the contents stored on your PC, local network, or the Internet. Your desktop screen will be mirrored to the B360 display regardless of the applications you are running on your PC.

There may be situations in which you want to write, highlight, mark, record video or cut-and-paste portions of your presentation materials directly on the desktop screen. Delta provides a simple-to-use tool for all of these functions – *NovoScreenote*. You can download the Windows PC or Mac PC versions of *NovoScreenote* from <http://www.deltaww.com/EduSolution>.



3.1.4 Step 4: Presentation management

3.1.4.1 Role assignment

There are three roles in a presentation group, the *host*, the *presenter*, and the *participant*. The first *participant* to start the presentation group is assigned the *host* role. Subsequent individuals that join are assigned the *participant* role.



At first, the *host* is defaulted to assume the *presenter* role until he hands over the *presenter* role to another *participant*.

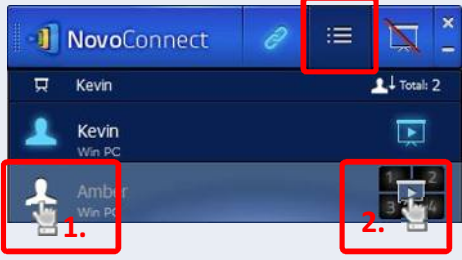



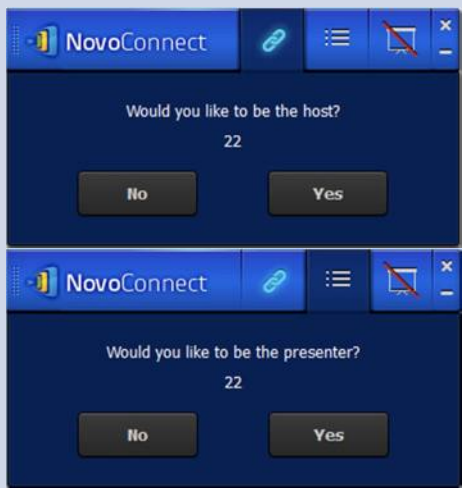
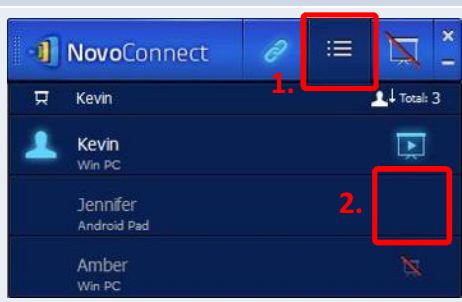



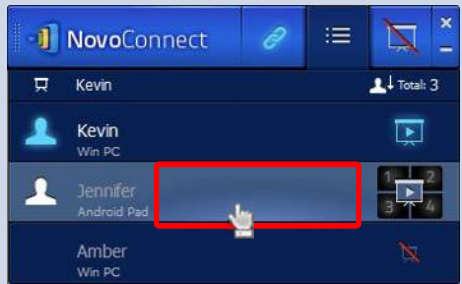
To show all current *participants* who have joined the presentation group, click the  tab.

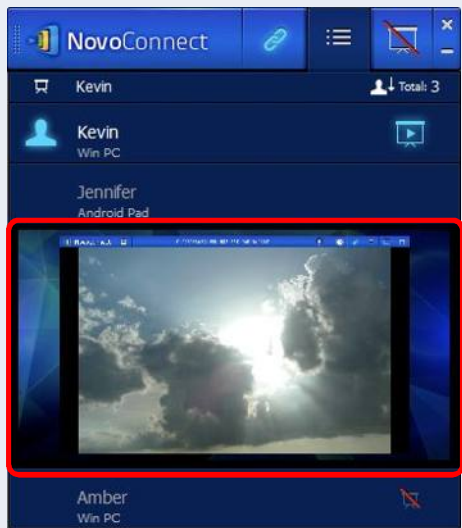
(Note: *Education Edition* does not have the screen preview control tab  or the  symbol.)

Function	Description
	<p>Click the  tab to show the participant list.</p> <ul style="list-style-type: none">  Indicates the current <i>host</i>.  Indicates the current <i>presenter</i>.  *Indicates a <i>participant</i> who has denied screen preview.  Indicates the current <i>presenter</i> that is presenting in the indicated split-screen box number (#1-4) (the icon shown here is for a <i>presenter</i> that is presenting in Box #1). <p>When no symbol appears in a participant line, it indicates that the <i>participant</i> is neither the host nor the presenter and has allowed screen preview.</p> <p>*: For the <i>Education Edition</i>, there is no screen preview control tab , and all participants will automatically allow screen preview as  will not appear for any participant.</p>
	<p>Indicate the names of the presenters, the participant list sorting method, and the total number of <i>participants</i>.</p> <p>For the participant list sorting method,  indicates that the list is sorted by participants' name in reverse alphabetical order.  Indicates that the list is sorted by the presentation group join time (most recent on top). Toggle between  or  to change the participant list sorting method.</p> <p>Example 1: Kevin is the only <i>presenter</i>. The participant list is sorted by participants' name in reverse alphabetical order. There are currently 3 <i>participants</i>.</p> <p>Example 2: Jennifer, Amber, John, and Katy are the four <i>presenters</i>. The participant list is sorted by the presentation group join time (most recent on top). And there are currently 6 <i>participants</i>.</p>
	<ol style="list-style-type: none"> 1. (Only for <i>participants</i> in the <i>Corporate Edition</i> that are not hosts) Toggle between  and  to accept or deny screen preview by the <i>host</i>, respectively. 2. The  symbol indicates that the <i>participant</i> denies screen preview by the <i>host</i>. 3. If you do not see the  symbol, the <i>participant</i> allows screen preview by the <i>host</i>.

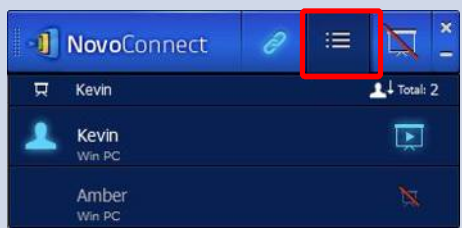
3.1.4.2 Role change, screen preview, and four-way split screen

(Note: *Education Edition* does not have the screen preview control tab  or the  symbol.)


Function	Description
	<p>To perform a role change:</p> <p>Click the  tab to show the <i>participant</i> list. Highlight a <i>participant</i> by moving the cursor onto the targeted participant.</p> <ol style="list-style-type: none"> 1. Click on  to hand over the <i>host</i> role to the participant. 2. Click on  to hand over the <i>presenter</i> role.
	<p>When a <i>participant</i> is asked to be a <i>host</i>, a dialog box will appear on the <i>participant's</i> screen. When a <i>participant</i> is asked to be a <i>presenter</i>, a dialog box will appear on the <i>participant's</i> screen. The <i>participant</i> has 20+ seconds to click the Yes button to accept or click the No button to reject the requested <i>role change</i>.</p>
	<p>To perform screen preview:</p> <ol style="list-style-type: none"> 1. Click the  tab to view the <i>participant</i> list. (Note: Only the <i>host</i> can preview the <i>participant's</i> screen.) 2. In this example, Jennifer's Android tablet is not displaying a  symbol, indicating that Jennifer is allowing <i>host</i> preview. <p>*: In the <i>Education Edition</i>, <i>host</i> preview is always allowed as all <i>participants</i> will automatically allow screen preview and  will not appear.</p>
	<p>Mouse over to highlight and click on the middle part of the entry for Jennifer.</p>





The diagram shows the *host* viewing the screen of Jennifer's Android tablet within the *participant* list.

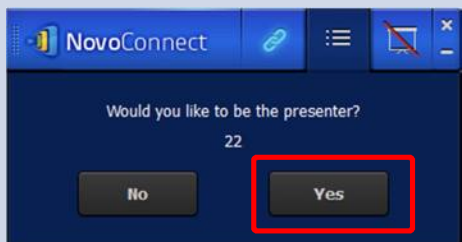


To perform a four-way split screen presentation:

Click the  tab to view the *participant* list. (Note: only the *host* may designate a four-way split screen presentation.)





1. Move cursor over to highlight *participant* Amber.
2. Click on a numbered box  to assign a *presenter's* on-screen display to the corresponding presentation screen (numbers 1-4). Click the center box  to show a *presenter's* on-screen display in full screen.

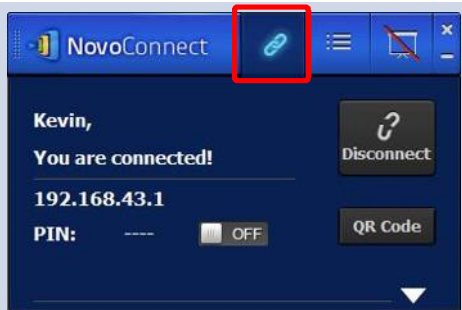



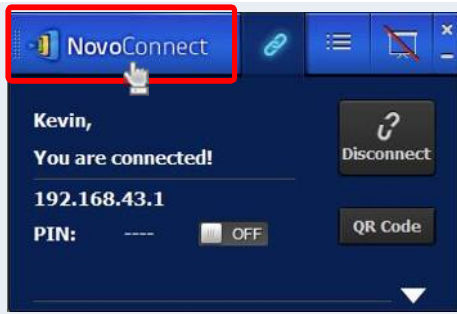
In the dialog box, we see that Amber has received a request to assume the *presenter* role.

After Amber clicks **Yes** to accept being a *presenter*, Amber's screen will appear in one of the four quarters of the four-way split screen.


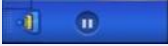

3.1.4.3 Pause, resume, and disconnect

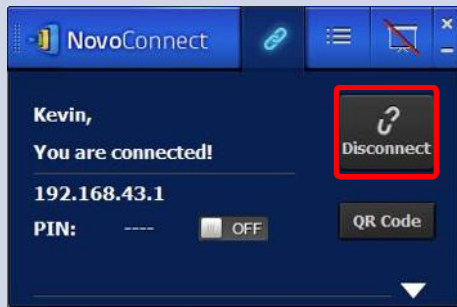
(Note: *Education Edition* does not have the screen preview control tab  or the  symbol.)

Function	Description
	<p>To pause/resume a presentation:</p> <p>Click the  tab to bring up the presentation control page.</p>




Pausing and resuming a presentation:

Move your cursor to the  tab. Toggle between  and  to pause and resume a presentation respectively.



To disconnect from a presentation group:

Click the  button to exit the presentation group.


If the *host* exits a presentation group without handing over the *host* role, all *participants* will receive a message prompting them to take over the *host* role. The first to respond to the prompt will assume the *host* role.

3.2 Presenting with iOS tablet (iPad)

The iOS version of the *NovoPresenter* app (pictured in the image below) enables an iPad device to connect to the B360 and make a presentation.



Launch Presentation Application

Launch the *NovoPresenter* application by selecting the *NovoPresenter* app icon  on your iPad. The *NovoPresenter* app will launch.

To make a presentation, follow the steps below:

Step 1: Connect to your B360 device

Step 2: Make a presentation


Step 3: Manage the presentation

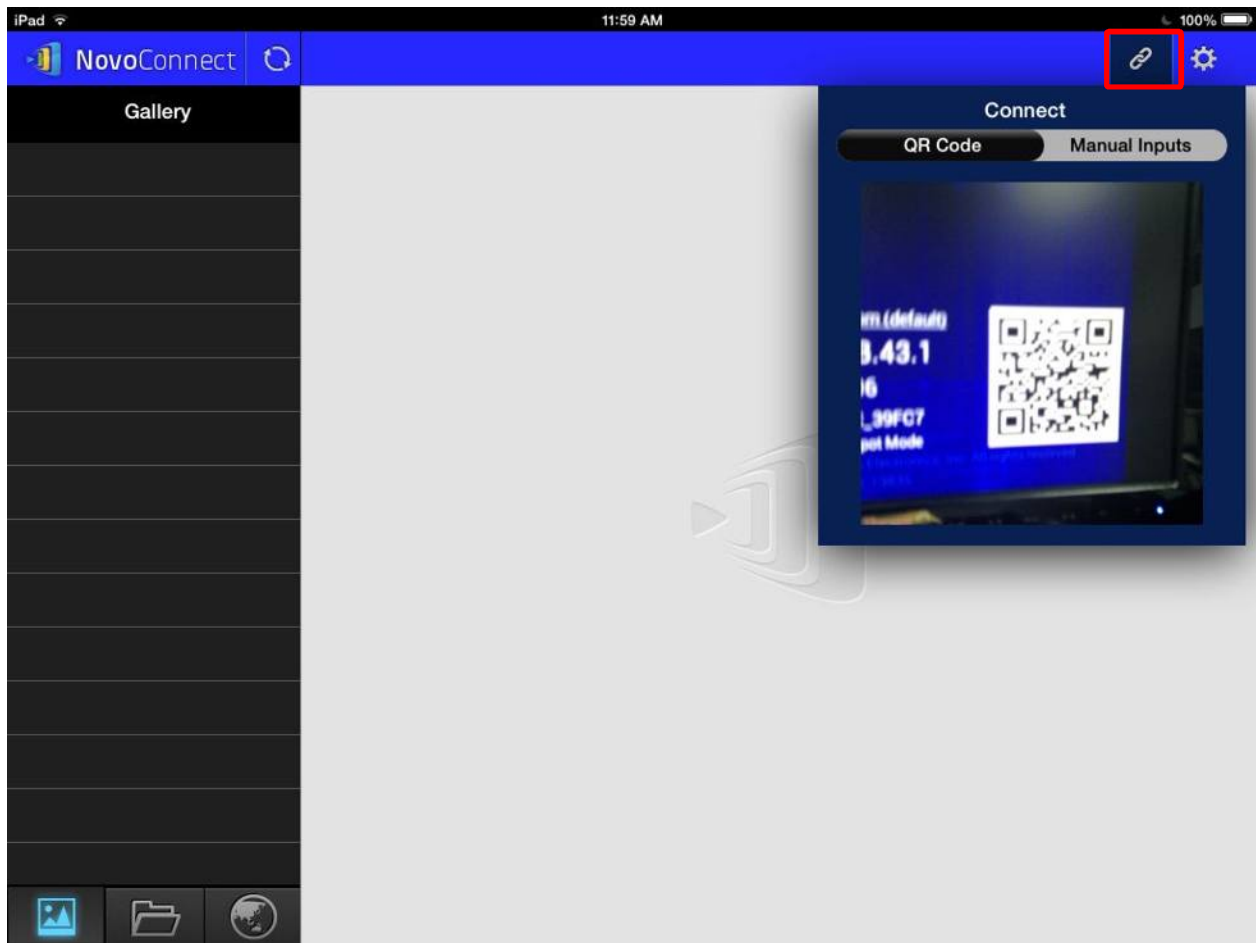
3.2.1 Step 1: Connect to your B360 device



There are two ways to connect to your B360 device:

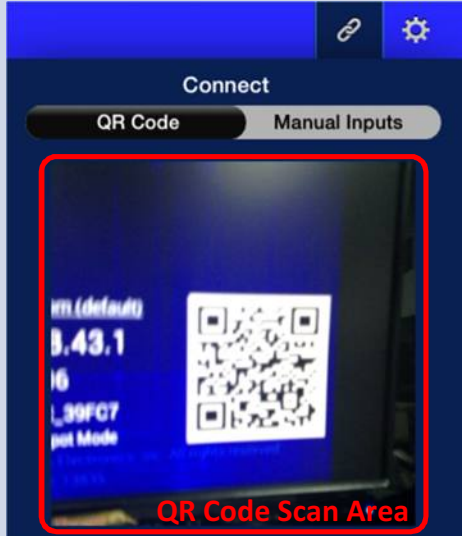
1. Connect to your B360 device automatically via QR code.
2. Connect to your B360 device manually.

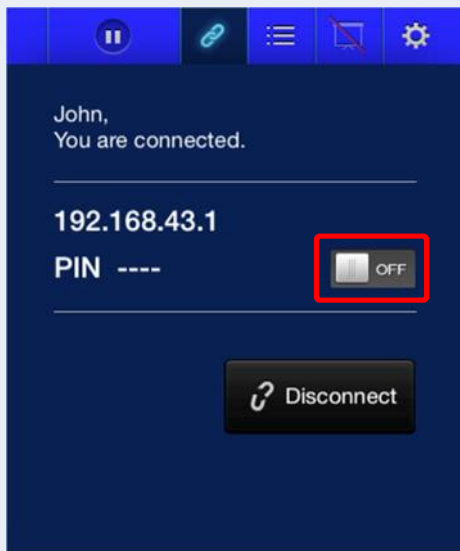
3.2.1.1 Connect to your B360 device automatically via QR Code

This is the default B360 connection option which allows you to connect to your B360 automatically without any manual configurations. After launching the *NovoPresenter* app, tap the  tab (as seen in the screenshot below) and access the connection options.




(Note: *Education Edition* does not have the screen preview control tab  or the  symbol.)

Function	Description
	<p>Connect to the B360 automatically via QR Code: The QR Code / Manual Inputs switch will be in the QR Code position by default (if not, just tap the switch once). Aim your tablet's camera at the QR code containing login information, which can be found on your B360 home screen or on the screen of the device connected to your B360. Under normal circumstances, <i>NovoPresenter</i> will automatically login to your B360. Should automatic login fail, follow the manual configuration option in section 3.2.1.2 Connect to your B360 device manually.</p>



Confirm connection:


After your *NovoPresenter* app on your iPad is connected successfully to your B360, the connection tab will light up

blue .

If you are the first *participant*, you will see that your iPad's on-screen display is wirelessly mirrored on your projector or TV display. You can slide the PIN requirement switch to **OFF** or **ON** to disable or enable usage of a PIN code.




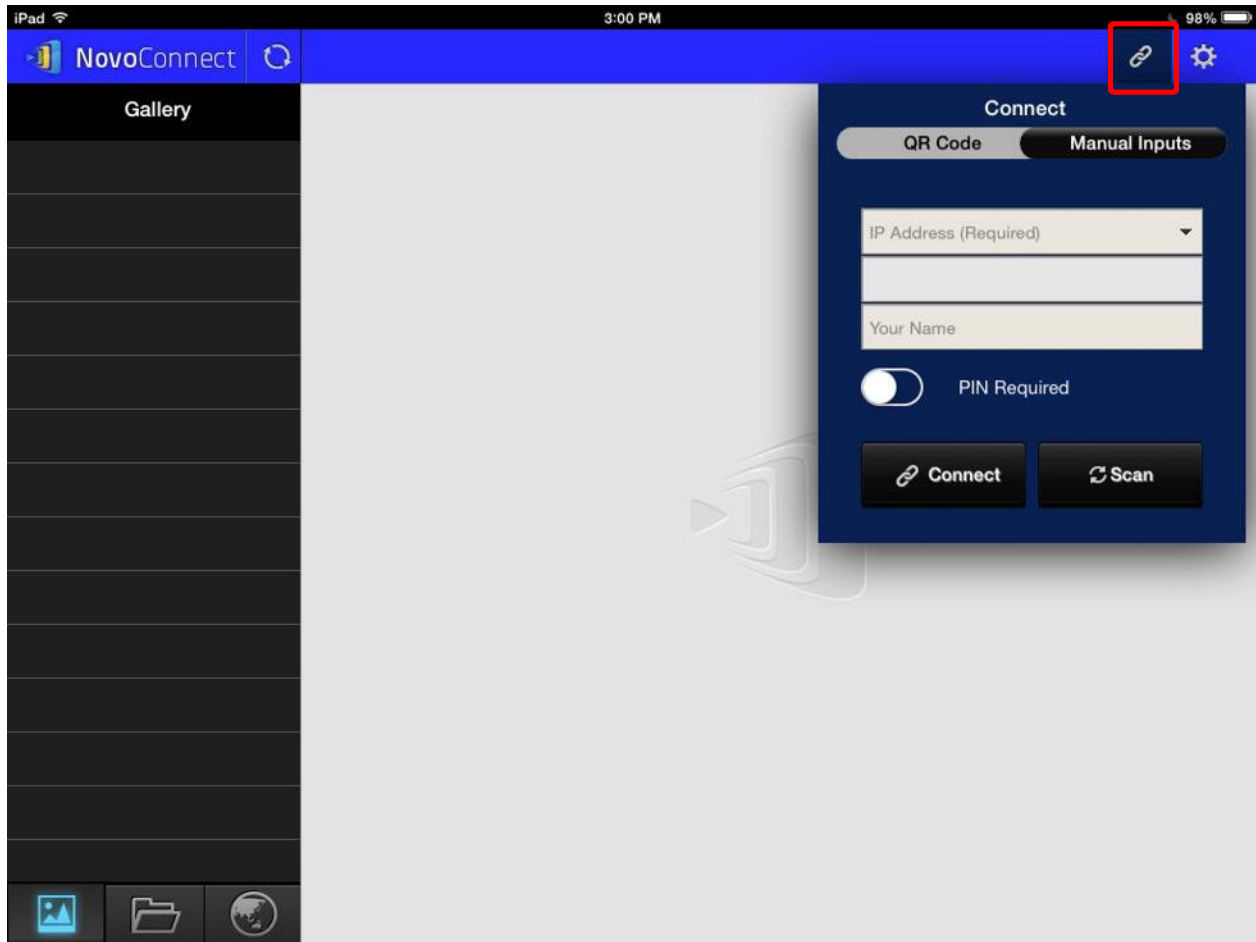
View participants list:



You can tap the  tab to see the current participant list.

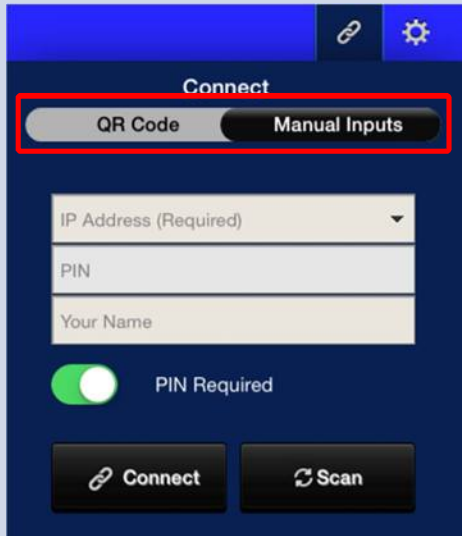
Example: There are a total of six *participants* in the presentation group shown at left. The *host* is John. However, John is not making a presentation at the moment because he has assigned Kevin, Amber, Jennifer, and Katy to be the four *presenters*.

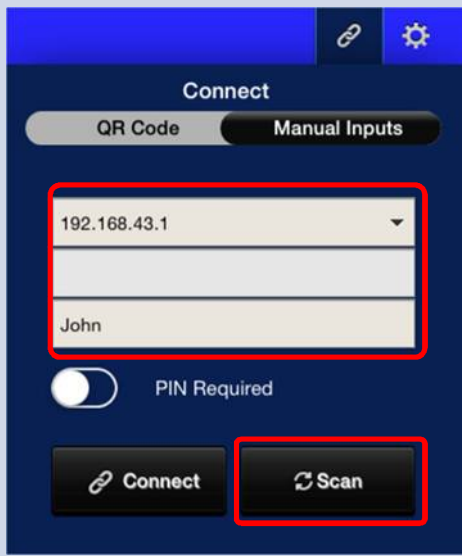
3.2.1.2 Connect to your B360 device manually

If you need to configure login information manually before connecting to your B360, this is the preferred connection option. After launching the *NovoPresenter* app, tap the  tab (as seen in the screenshot below) to access the configuration options.



(Note: *Education Edition* does not have the screen preview control tab  or the  symbol.)

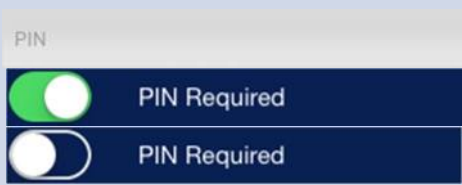
Function	Description
	<p>Manual configuration option: Toggle the QR Code / Manual Inputs switch to the Manual Inputs position.</p>



IP Address:

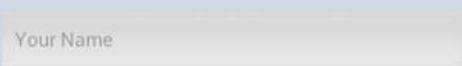
Manually enter the IP address shown on your NovoConnect home screen here, or select an entry from the drop down menu that matches the IP address shown on your NovoConnect home screen.

You can tap the **Scan** button to scan the IP addresses of all available B360s within the same subnet. Select the drop-down menu to see the available B360s within your area. Example: [192.168.43.1](#).



PIN:

If a PIN code is required to connect to the B360, slide the **PIN Required** switch to the ON position and enter the PIN shown on the NovoConnect home screen. If the PIN code is not required, slide the **PIN Required** switch to the OFF position.

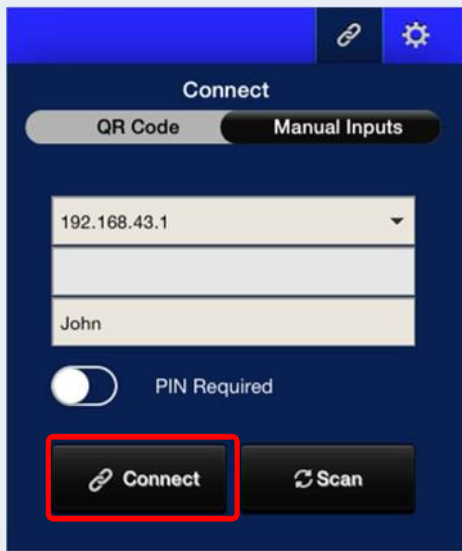


Your Name:

(Optional) Manually enter a name for this tablet to be identified by in the presentation group among the other *participants*.

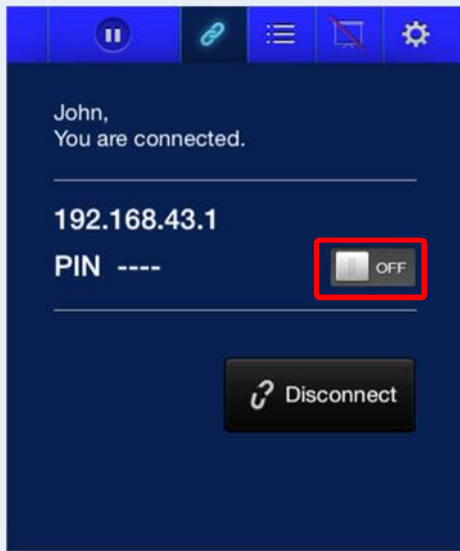
Example: Jennifer.

(Note: If a name is not entered in this field, the default name for your device will be used.)




Make Connection:

Tap the **Connect** button. If you are the first *participant*, this will start a presentation group on your B360. If you are not the first *participant*, you will be joining a presentation group.



Confirm Connection:


After your *NovoPresenter* app on your iPad connects successfully to your B360, you will see the connection tab

light up blue 

If you are the first *participant*, you will see that your iPad's on-screen display is wirelessly mirrored on your projector or TV display. You can slide the PIN requirement switch to **OFF** or **ON** to disable or enable usage of a PIN code.



View participants list:

You can tap the  tab to see the current participant list.

Example: There are a total of six *participants* in the presentation group shown at left. The *host*, John, is not making a presentation at the moment because he has assigned Kevin, Amber, Jennifer, and Katy to be the four *presenters*.

3.2.3 Step 3: Make a presentation

Once you have started/joined a presentation group, you can make a presentation with the contents stored on your iPad, local network, or the Internet. There are three tabs on the lower left corner of the *NovoPresenter* home screen:



: Tap this tab to present an image stored on your iPad.

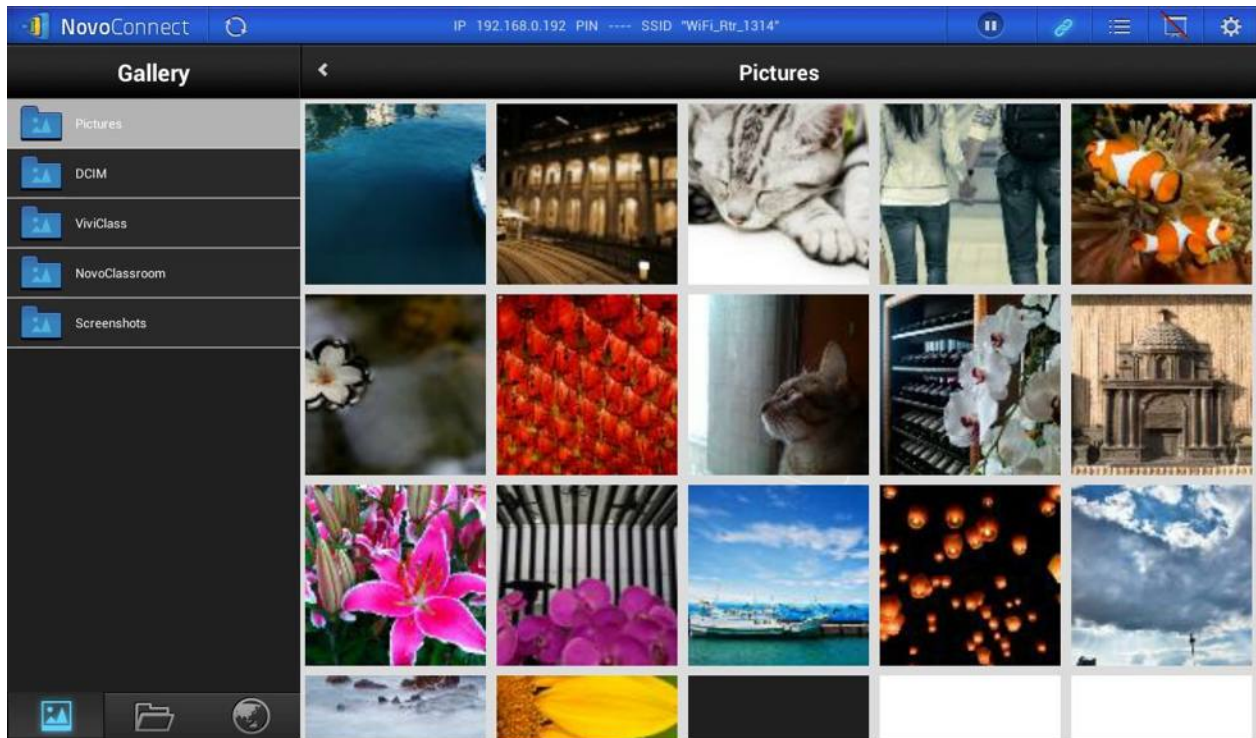


: Tap this tab to present a document stored on your iPad.





: Tap this tab to present a Web page.

3.2.3.1 Presenting an image



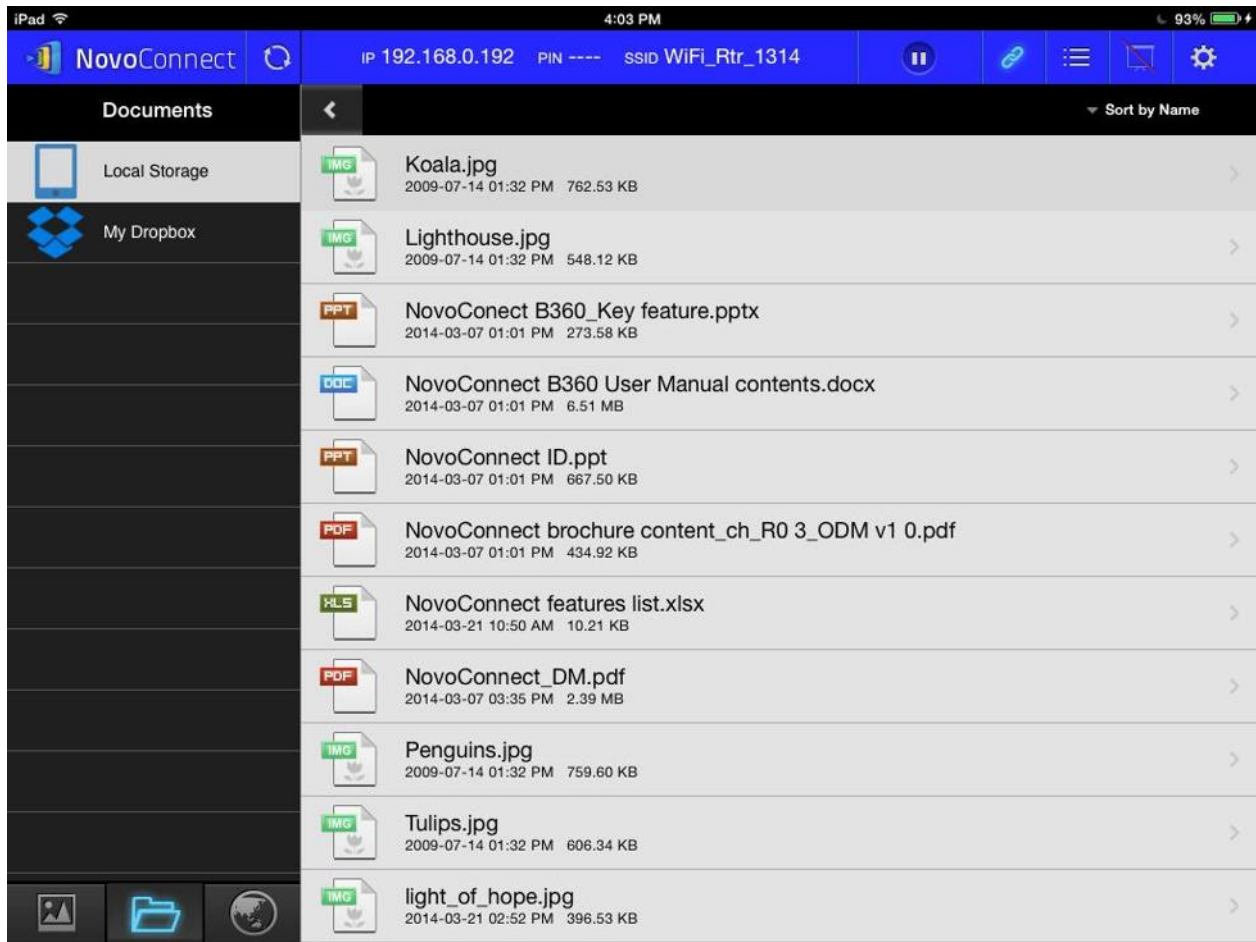
To import presentation files to an iPad, please refer to the iPad user manual. A sample iTunes screen is presented in the diagram below.





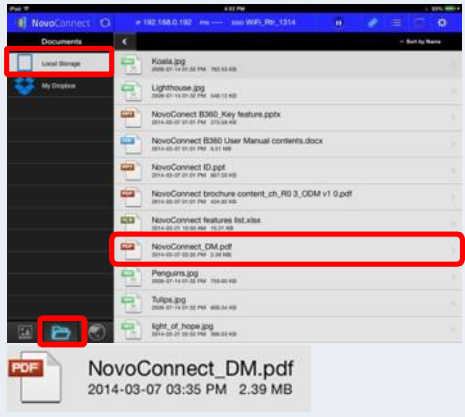

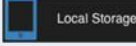
(Note: *Education Edition* does not have the screen preview control tab  or the  symbol.)

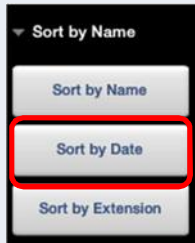
Function	Description
	<p>Import: Please refer to the iTunes user manual for the procedure for importing images to your iPad for presentation.</p>
	<p>Navigation: Tap the  tab to access folders with image files. The image symbol will light up blue. Navigate to a folder by tapping on the desired folder icon. Tap the return tab  to return to previous folder.</p>
	<p>Image thumbnails: You will see thumbnails of your image files displayed once you navigate to a folder containing the images. You can select a thumbnail to view the full image. Example: Tap on the ancient building image thumbnail. Note: Tap the  tab at any time to return to the previous folder. Tap the  tab at any time to refresh the screen.</p>
	<p>Image presentation: The selected image will be displayed in full screen. You can zoom in on the image by sliding two fingers apart (what Apple refers to as the “pinch open” gesture), or you can zoom out of the image by sliding two fingers toward each other (“pinch close”). If you have more than one image in the same folder, you can swipe your finger left or right across the screen to advance to the next or previous image.</p>
	<p>To return to the <i>Image Thumbnails</i> page, tap the  tab. To use the on-screen annotation tools, tap the  tab.</p>

3.2.3.2 Presenting a document (local storage)




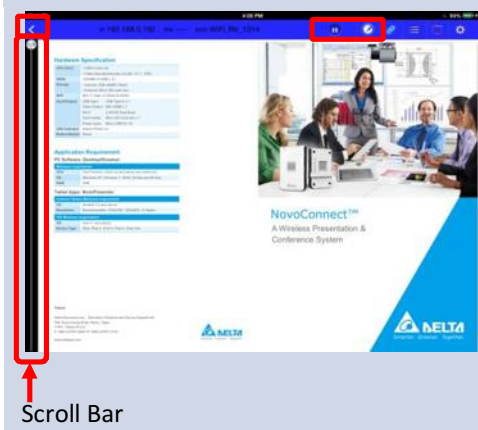
(Note: *Education Edition* does not have the screen preview control tab  or the  symbol.)

Function	Description
	<p>Import: Using the iTunes software, import the desired presentation documents to your iPad.</p>
	<p>Navigation: Tap the  tab to access folders with presentation files. The folder image will light up blue. If locally stored content is not displayed, tap the  tab. Navigate to a folder by tapping the desired folder. The document list will display documents that are supported by <i>NovoPresenter</i>. Locate and tap the desired document. Example: Tap the document "NovoConnect_DM.pdf".</p> <p>If you wish to sort the folder list into a desired order, tap the Sort by... tab on the drop-down menu, then select one of the following options:</p> <ul style="list-style-type: none"> - Sort by Name (default) - Sort by Date - Sort by Extension





Example: Tap the **Sort by...** drop-down menu. Select the option *Sort by Date* by tapping the **Sort by Date** button.

Note: You can tap the  tab at any time to refresh the screen contents.





Document presentation:


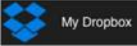

The selected document will be displayed in full screen. You can zoom in on the document by sliding two fingers apart (pinch open), or you can zoom out on the document by sliding two fingers toward each other (pinch close). To scroll down or move to the next page, slide your finger up or drag the scroll bar down. To scroll up or move to the previous page, slide your finger down or drag the scroll bar up.

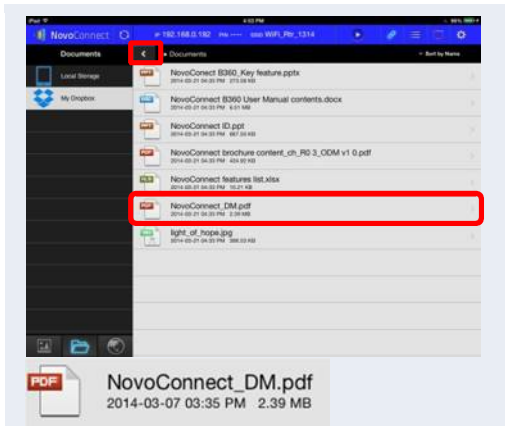
To return to the *Document List* page, tap the  tab. To use the on-screen annotation tools, tap the  tab.

3.2.3.2 Presenting a document (with Dropbox)




(Note: *Education Edition* does not have the screen preview control tab  or the  symbol.)

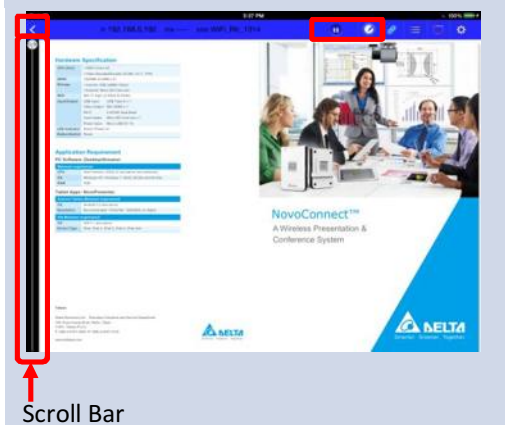
Function	Description
	<p>Set your B360 to Client Mode: Set your B360's Wi-Fi mode to Client Mode and connect to a Wi-Fi AP router with Internet access.</p>
	<p>Select Dropbox as the document source: Tap the folder tab . It will light up blue. Tap the My Dropbox  tab.</p>
	<p>First time using Dropbox in NovoPresenter: When using the <i>NovoPresenter</i> Dropbox feature for the first time, a link between <i>NovoPresenter</i> and your Dropbox account will need to be established. Enter the e-mail address associated with your Dropbox account in the <i>Email</i> field and the associated password in the <i>Password field</i>, and then tap the Sign In button.</p>
	<p>Navigation: By default, your Dropbox's home directory contents will be displayed first. Navigate to a folder by tapping the desired folder. If you wish to sort the list into a desired order, tap the Sort by... drop-down menu then select one of the following options:</p> <ul style="list-style-type: none"> - Sort by Name - Sort by Date (default) - Sort by Extension <p>Example: Tap the Sort by... drop-down menu. Tap the option <i>Sort by Name</i>, and then tap the <i>Documents</i> folder.</p> <p>Note: You can tap the  tab at any time to return to previous folder. You can also tap the  tab at any time to refresh the Dropbox list (you will be returned to your Dropbox list's home directory). You can tap the  tab at any time to refresh the screen contents.</p>




Document list:

Once you locate the desired document, you can open and present the document page by page from the Dropbox Web site without having to download the document to your iPad. Example: Tap the document “NovoConnect_DM.pdf”.



Note: You can tap the  tab at any time to return to the previous folder.

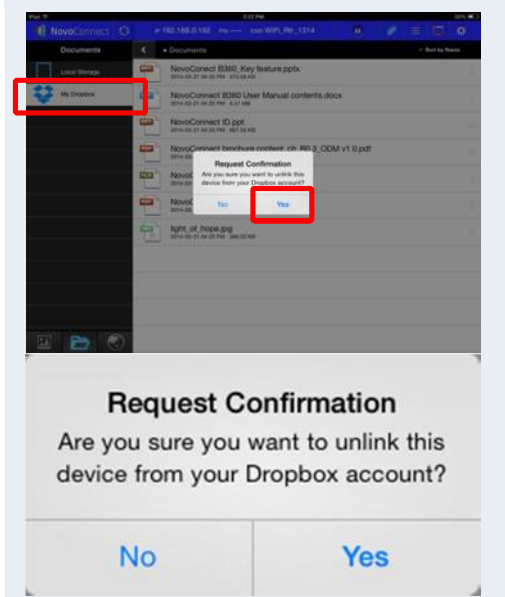


Document presentation:

The selected document will be displayed in full screen. If your presentation is paused, tap the  button to resume the presentation. You can zoom in on the document by sliding two fingers apart (pinch open), or you can zoom out on the document by sliding two fingers toward each other (pinch close).


To scroll down or move to the next page, slide your finger up or drag the scroll bar down. To scroll up or move to the previous page, slide your finger down or drag the scroll bar up.

To return to the *Document List* page, tap the  tab. To use the on-screen annotation tools, tap the  tab.



Unlink Device from Dropbox:



If you need to unlink the *NovoPresenter* app from your


Dropbox account, tap and hold the  My Dropbox tab for a few seconds. When the *Request Confirmation* appears, tap **Yes** to proceed.

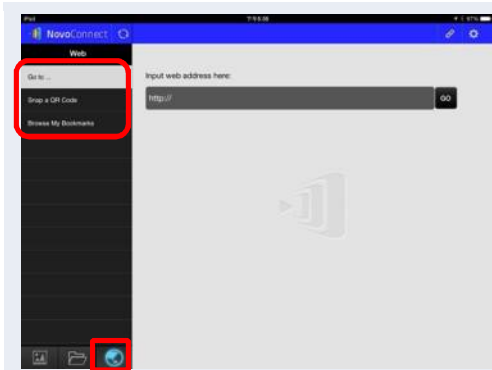
3.2.3.3 Presenting with a browser

To include a browser in your presentation, please follow the steps listed in the table below. For reference, a sample screen is also shown below.




(Note: *Education Edition* does not have the screen preview control tab  or the  symbol.)

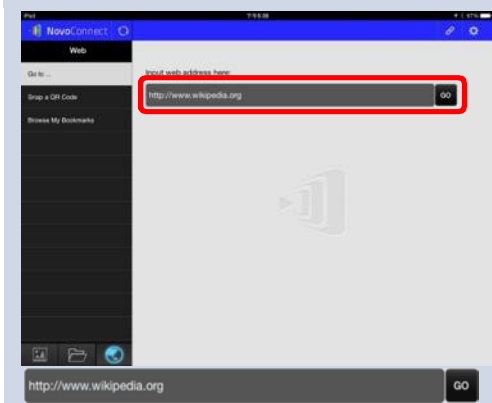
Function	Description
	<p>Set your B360 to Client Mode: Set your B360's Wi-Fi mode to Client Mode and connect to a router with Internet access. Please refer to the <i>Remote Viewer</i> chapter for more details.</p>



Start browsing for a Web page:

Tap the Internet tab . It will light up blue. Select one of the three options to access a Web page:

- Go to... (enter URL address[default])
- Snap a QR Code
- Browse My Bookmarks (Web site bookmarks)

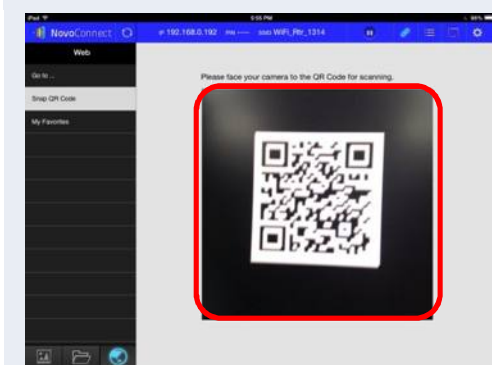


Go to...:

Tap the **Go to...** tab.

Enter the Web page URL and tap **Go**.

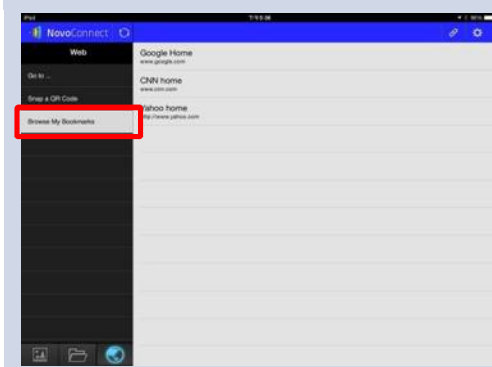
Example: Enter the URL www.wikipedia.org and tap **Go** (the pre-fix <http://> can be omitted).



Snap QR code:

Tap the **Snap QR Code** tab.

Aim your iPad's camera at a QR code containing Web page information. *NovoPresenter* will detect the URL and access the corresponding Web page.



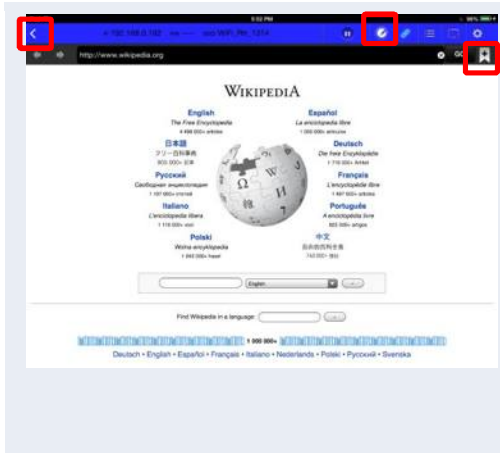
Browse my Bookmarks:

Tap the **Browse my Bookmarks** tab.

From the bookmark list, tap the bookmark of interest to go to its corresponding Web page.

Touch and hold a bookmark for two seconds to edit or delete the bookmark.


Note: The bookmark list may initially be empty. You can add a Web page to the bookmark list at any time while browsing and presenting Web pages.





Web page presentation:

The selected Web page is fully displayed. You can zoom in on the Web page by sliding two fingers apart (pinch open), or you can zoom out of the Web page by sliding two fingers toward each other (pinch close).



To scroll down or move to the next page, slide your finger up. To scroll up or move to the previous page, slide your finger down.

To add this Web page to the bookmark list, tap the  tab.











To return to the *Web menu page*, tap the  tab. To use the on-screen annotation tools, tap the  tab.

3.2.3.4 Annotation

Sometimes you may want to write, highlight, or mark portions of your presentation materials directly on the tablet screen. *NovoPresenter* provides an on-screen annotation tool for the *presenter* to annotate the presentation material directly without changing the original. You can

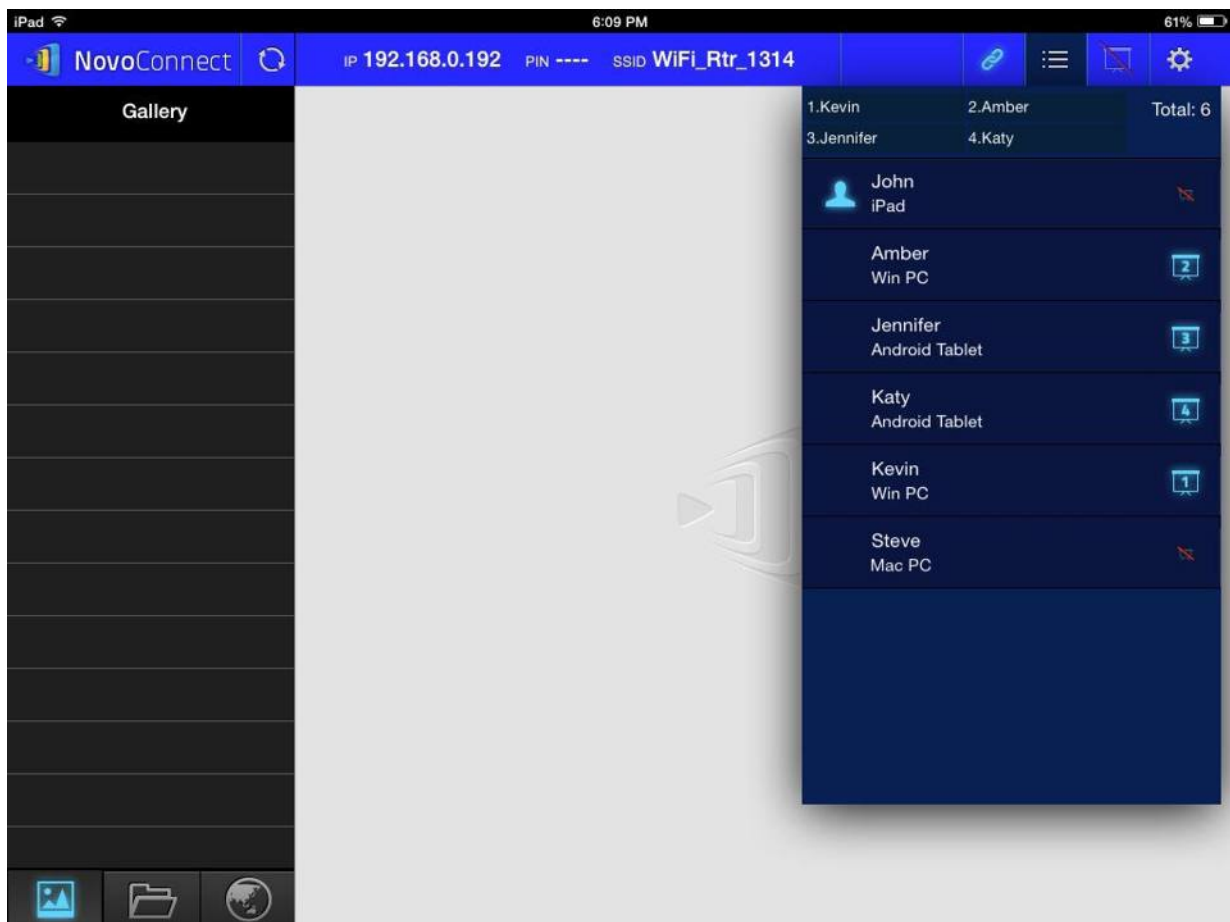
enable the annotation tool  by toggling the  tab on, as shown in the screenshot below.



Function	Description
	<p>Tap the  tab to enable the annotation tool.</p> <ul style="list-style-type: none">  Annotate with a red marker  Annotate with a blue marker  Annotate with a black marker  Annotate with a yellow highlighter  Change from annotation (writing) mode to touch panel (operation) mode  Trash can  Eraser  Undo

3.2.4 Step 4: Presentation management


Once you are done starting/joining a presentation group, you are ready to make a presentation and collaborate with other *participants*. A sample screen view is provided below.






3.2.4.1 Role assignment

There are three roles in a presentation group, the *host*, the *presenter*, and the *participant*. The first person to start a presentation group with a B360 is assigned the *host* role. Subsequent joiners are assigned the *participant* role.



The *host* is defaulted to assume the *presenter* role until he hands over the *presenter* role to another *participant*.

To show all current *participants* who have joined the presentation group, please tap the  tab.

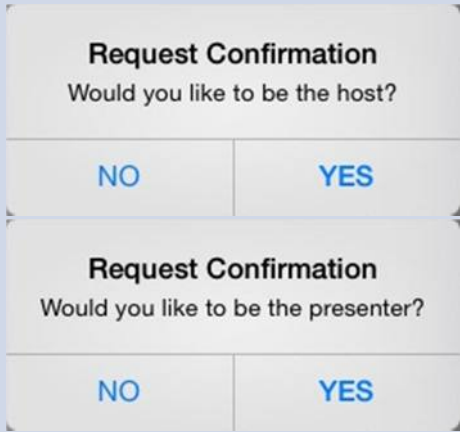
(Note: *Education Edition* does not have the screen preview control tab  or the  symbol.)

Function	Description
	<p>Select the  tab to show the <i>participant</i> list.</p> <ul style="list-style-type: none">  indicates the current <i>host</i>.  indicates the current <i>presenter</i>.  *indicates a <i>participant</i> who has denied screen preview.  indicates the current <i>presenter</i> that is presenting in the indicated split-screen box number (#1-4). The instance here shows a <i>presenter</i> that is presenting in Box #1. <p>Example: There are six <i>participants</i> in the presentation group – one with an iPad, two with Windows PCs, two with Android tablets, and one with a Mac PC. John is the <i>host</i> who automatically has denied screen preview. Kevin, Amber, Jennifer, and Katy are <i>presenters</i> currently presenting in boxes #1-4 of the four-way split screen (which will be explained in detail later). Steve is a <i>participant</i> who has denied screen preview.</p> <p>*For the <i>Education Edition</i>, there is no screen preview control tab , and all participants will automatically allow screen preview as  will not appear for any participant.</p>
	<p>Indicates the names of the <i>presenters</i> seen by other <i>participants</i> and the total number of current <i>participants</i>. Example 1: Oliver is the only <i>presenter</i>, and there are currently 2 <i>participants</i>. Example 2: Kevin, Amber, Jennifer, and Katy are the four <i>presenters</i>, and there are currently 6 <i>participants</i>.</p>
	<p>(For non-<i>host participants</i> in <i>Corporate Edition</i> only) Toggle between  and  to accept or deny screen preview by the <i>host</i>, respectively.</p>

3.2.4.2 Role change, screen preview, and four-way split screen

(Note: *Education Edition* does not have the screen preview control tab  or the  symbol.)



Function	Description
	<p>To perform a role change:</p> <p>First select the  tab to show the <i>participant</i> list.</p>
	<ol style="list-style-type: none"> 1. Highlight <i>participant</i> Amber by tapping the middle part of Amber's entry once or twice until both the  and the  icons appear. 2. Tap Amber's  icon to hand over the <i>host</i> role to her. 3. If the split screen selection area  is <i>not</i> yet present, touch the  icon to bring up the split screen selection area. 4. Tap the  icon of the split screen selection area to request Amber to be the sole <i>presenter</i>. 5. Tap one of the four boxes (#1-4) in the split screen selection area to allow Amber to perform a presentation on one of the four boxes of the four-way split screen.

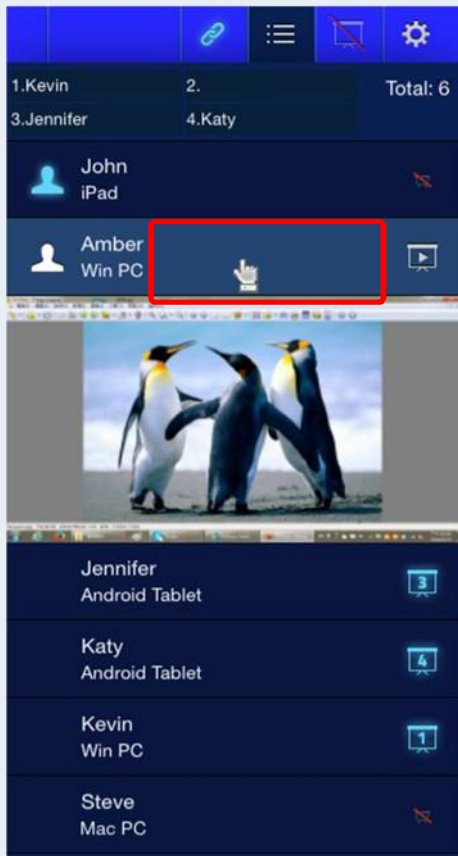




When a *participant* is asked to be a *host*, a dialog box will appear on the *participant's* screen. Also, when a *participant* is asked to be a *presenter*, a dialog box will appear on the *participant's* screen. The *participant* has 20+ seconds to tap the **Yes** button to become the new *host* or tap the **No** button to reject the *host* assignment.



To perform screen preview:


Tap the  tab to show the *participant* list. The *participant* Amber does not have an  icon, indicating that she has allowed screen preview.



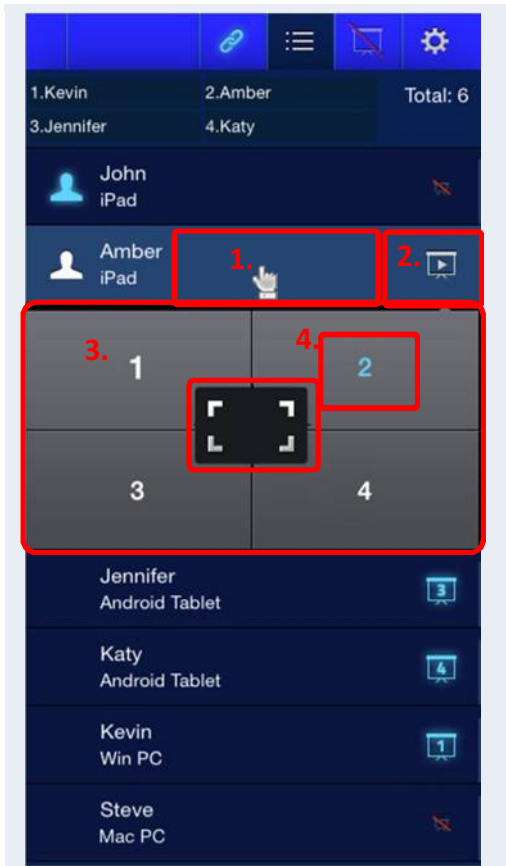
To preview a *participant's* screen, tap the middle part of an entry once or twice to bring up both the  and the  icons. Wait for a few seconds for the screen to be sampled and displayed. In this example, Amber's Win PC is selected to be previewed.







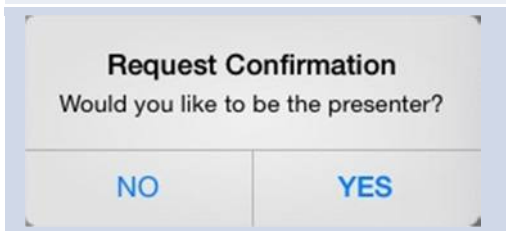
To perform a four-way split screen presentation:

Tap the  tab to show the *participant* list.

Select a *participant* to make a presentation. In this example, Amber has been selected.







1. Tap Amber's entry once or twice until both the  and the  icons appear.
2. If the split screen selection area  is not yet present, tap the  icon to bring up the split screen selection area.
3. Tap one of the four boxes (#1-4) in the split screen selection area to assign Amber to perform a presentation on one of the four boxes of the four-way split screen.
4. In this example, Amber is assigned to make a presentation in Box #2.

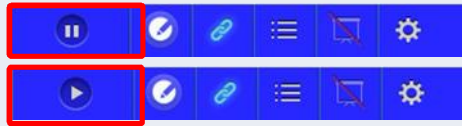


Amber will receive a request to perform a presentation on one of the four boxes of the four-way split screen. After John accepts (within 20+ seconds) being one of the four possible *presenters* (by tapping the **Yes** button), John's screen will appear in one of the four boxes of the four-way split screen.

3.2.4.3 Pause, resume, and disconnect

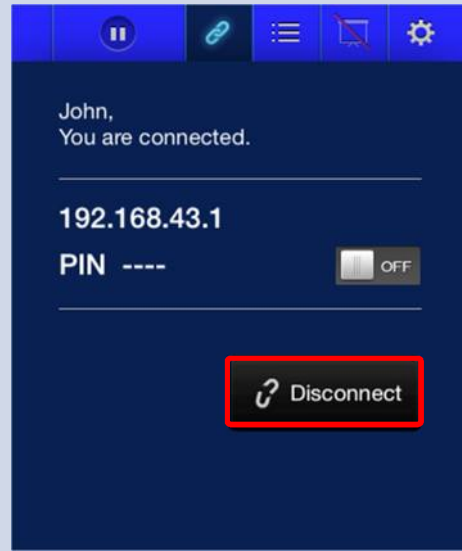
(Note: *Education Edition* does not have the screen preview control tab  or the  symbol.)

Function	Description
	<p>To pause a presentation:</p> <p>Tap the  tab to enter the presentation control page.</p>



Pausing and resuming a presentation:

While presenting, the *presenter* can toggle between  and  to pause and resume the presentation respectively.





To disconnect from a presentation group:




Tap the **Disconnect** button to exit the presentation group.

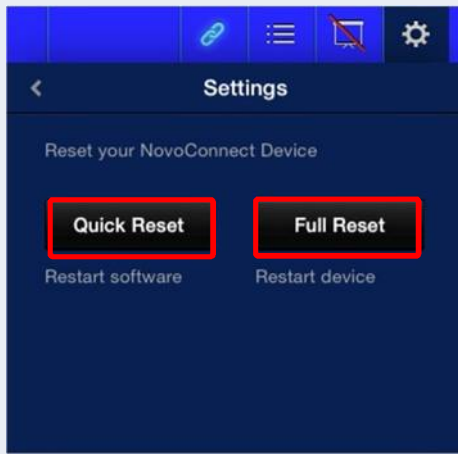
If the *host* exited the presentation session without handing over the *host* role, all *participants* will receive a message prompting them to take over the *host* role. The first to respond to the prompt will assume the role of the *host*.

3.2.4.4 Reset

Occasionally you may encounter problems with the network or the computer causing the presentation group to malfunction on your B360. One way to resolve this problem is to reset the presentation group.

(Note: *Education Edition* does not have the screen preview control tab  or the  symbol.)

Function	Description
	<p>To perform a reset:</p> <p>First tap the  tab and tap the  arrow of the Device's Reset window.</p>



Resetting:

Tap the **Quick Reset** to reset the presentation group to allow a presentation group to start over again.

Tap the **Full Reset** button to reset the NovoConnect B360 device. The B360 device will restart automatically.

Conflicts may occur when multiple *participants* simultaneously attempt to reset the presentation group or the B360. The reset privilege priorities are as follows:


1. *Host*: The *host* has the sole privilege to quick-reset the presentation group or the B360 device when the *host* stays connected to the B360.
2. *Presenter*: If the *host* lost connection with the B360, the current *presenter* inherits the privilege to quick-reset the B360.
3. *Participant*: If the *host* and the *presenter* both lost connection with the B360, any *participant* can quick-reset the presentation group.

3.3 Presenting with Android Tablet

The Android version of the *NovoPresenter* app (pictured in the image below) enables an Android tablet device to connect to the B360 and make a presentation.



Launch Presentation Application

Launch the *NovoPresenter* application by selecting the *NovoPresenter* app icon  on your Android tablet. The *NovoPresenter* app will be launched.

To make a presentation, follow the steps below:

Step 1: Connect to your B360 device

Step 2: Make a presentation


Step 3: Manage the presentation

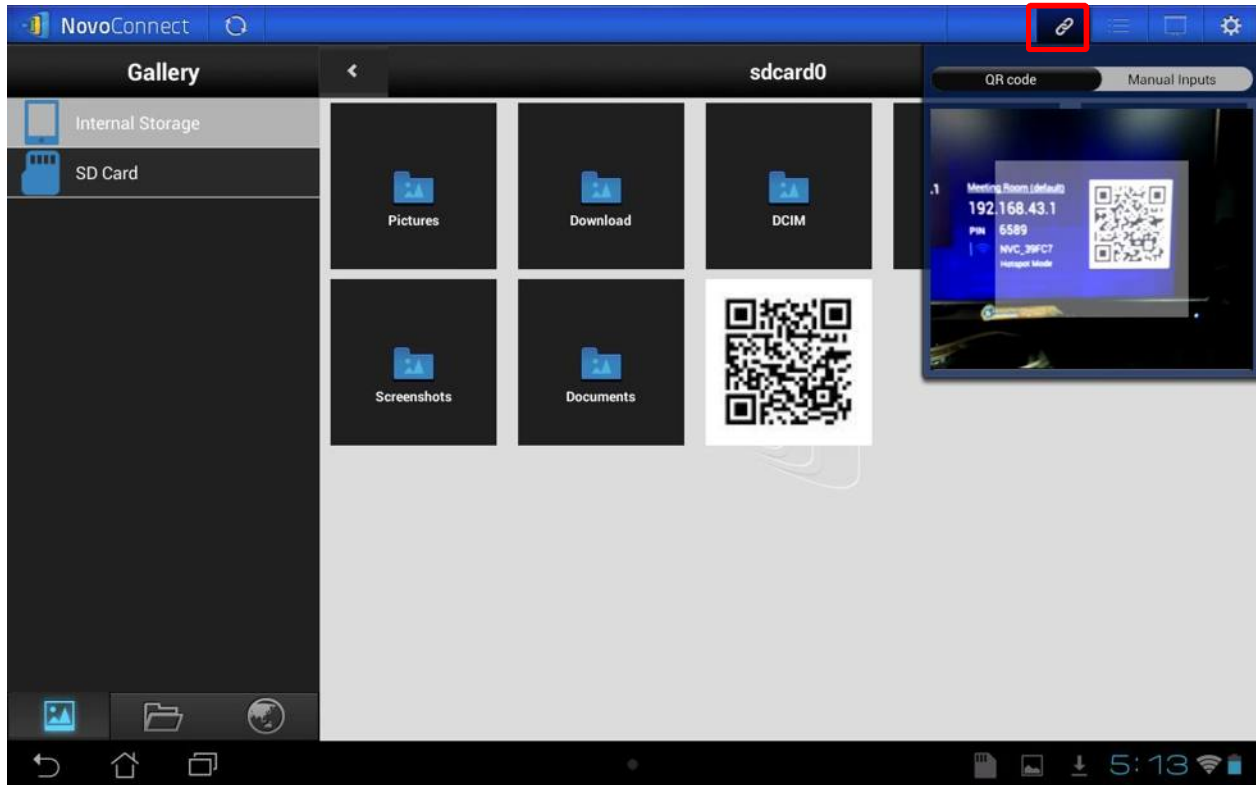
3.3.1 Step 1: Connect to your B360 Device



There are two ways to connect to your B360 device:

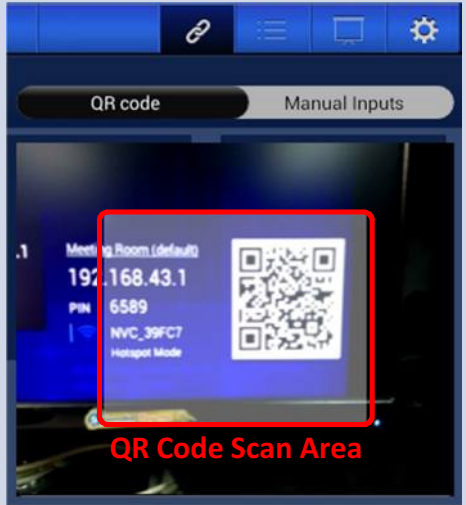
1. Connect to your B360 device automatically via QR Code.
2. Connect to your B360 device manually.

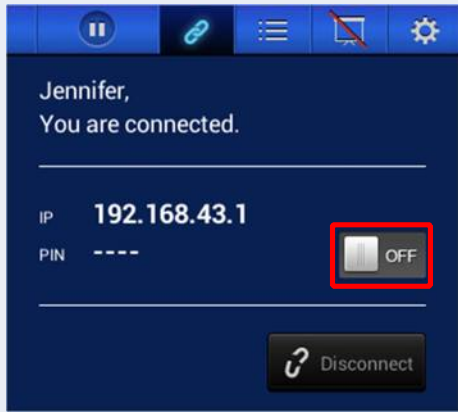
3.3.1.1 Connect to your B360 device automatically via QR Code

This is the default B360 connection option which allows you to connect to your B360 automatically without any manual configurations. After launching the *NovoPresenter* app, tap the  tab (as seen in the screenshot below) and access the connection options.




(Note: *Education Edition* does not have the screen preview control tab  or the  symbol.)

Function	Description
	<p>Connect to the B360 automatically via QR Code: The QR code / Manual inputs switch will be in the QR code position by default (if not, just tap the switch once). Aim your tablet's camera at the QR code containing login information, which can be found on your B360 home screen or on the screen of the device connected to your B360. Under normal circumstances, <i>NovoPresenter</i> will automatically login to your B360. Should automatic login fail, follow the manual configuration option in the section 3.3.1.2 Connect to your B360 device manually.</p>

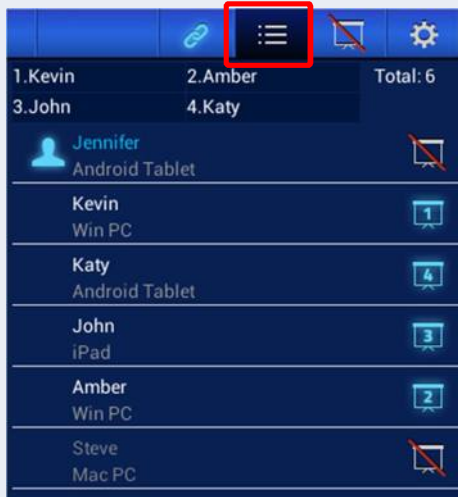


Confirm Connection:


After your *NovoPresenter* app on your Android tablet is connected successfully to your B360, you will see the

connection tab light up blue .

If you are the first *participant*, you will see that your Android tablet's on-screen display is wirelessly mirrored on your projector or TV. You can slide the PIN requirement switch to **OFF** or **ON** to disable or enable usage of a PIN code.



View participants list:

You can tap the  tab to see the current *participant* list.


Example: There are a total of six *participants* in the presentation group. Jennifer the *host*. However, she is not making a presentation at the moment. She has assigned Kevin, Amber, John, and Katy to be the four *presenters*.

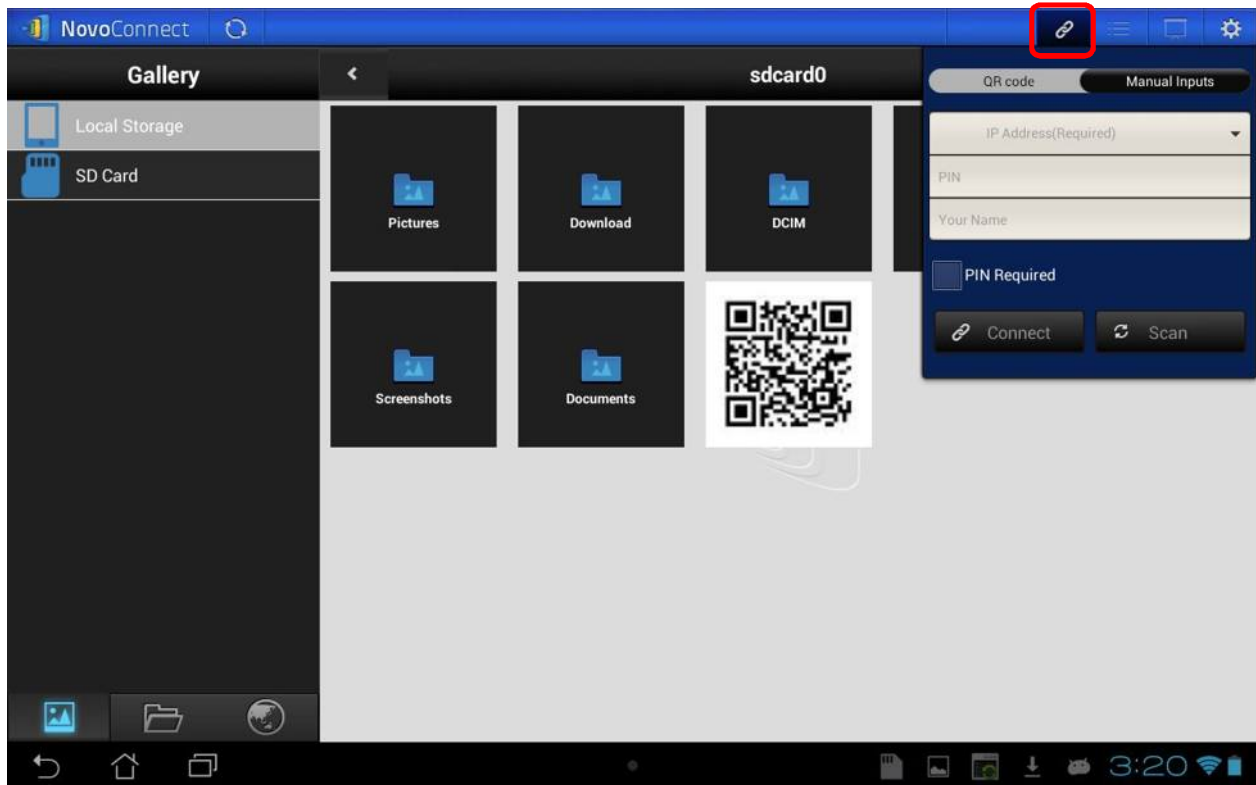




Allow other users to connect to the B360 automatically via QR Code:


1. For the first *participant*, *NovoPresenter* automatically generates a QR code on your Android device's home directory (which is mirrored on your projector or TV) to allow other subsequent users to connect to your B360 automatically. Subsequent users can follow the steps described above to scan the QR code and connect automatically to your B360. Upon starting the *NovoPresenter*, you should be able to find the QR code image being displayed.
2. a) After making a connection with your B360, you can also display a larger QR code for others to login by tapping the session information tab.
b) A larger QR code with session information will be displayed. Click **Ok** when done.

3.3.1.2 Connect to your B360 device manually

If you need to configure login information manually before connecting to your B360, this is the preferred connection option. After launching the *NovoPresenter* app, tap the  tab (as seen in the screenshot below) and access the configuration options.



(Note: *Education Edition* does not have the screen preview control tab  or the  symbol.)

Function	Description
	<p>Manual configuration option: Toggle the QR code / Manual Inputs switch to the Manual Inputs position.</p>



IP address:

Manually enter the IP address shown on your NovoConnect home screen here, or select an entry from the drop-down menu that matches the IP address shown on your NovoConnect home screen.

You can tap the **Scan** button to scan the IP addresses of all available B360s within the same subnet. Select the drop-down menu to see the available B360s within your area. Example: 192.168.43.1.



PIN:

If a PIN code is required to connect to the B360, check the **PIN Required** box and enter the PIN shown on the NovoConnect home screen. If a PIN code is not required, uncheck the **PIN Required** check box.

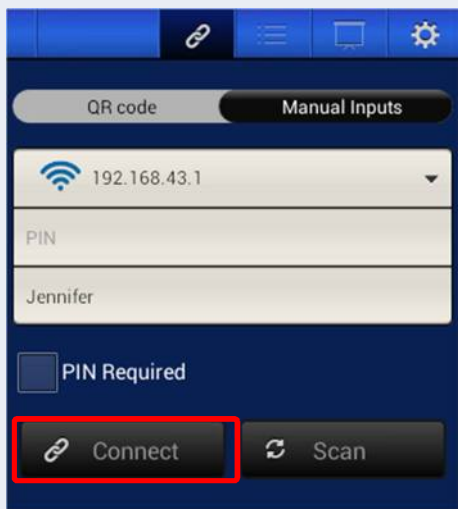


Your Name:


(Optional) Manually enter a name for this tablet to be identified in the presentation group among other *participants*.

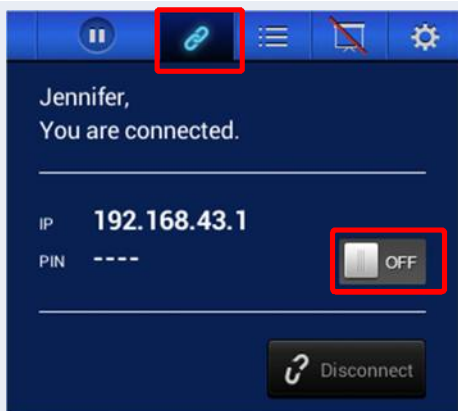
Example: Jennifer.

(Note: If a name is not entered in this field, the default name for your device will be used.)




Make connection:

Tap the  button. If you are the first *participant*, this will start a presentation group on your B360. If you are not the first *participant*, you will be joining a presentation group.



Confirm connection:


After your *NovoPresenter* app on your Android tablet is connected successfully to your B360, you will see the

connection tab light up blue .

If you are the first *participant*, you will see that your Android tablet's on-screen display is wirelessly mirrored on your projector or TV. You can slide the PIN requirement switch to **OFF** or **ON** to disable or enable usage of a PIN code.



View participants list:

You can tap the  tab to see the current *participant* list. Example: There are a total of six *participants* in the presentation group. Jennifer the *host*. However, she is not making a presentation at the moment. She has assigned Kevin, Amber, John, and Katy to be the four *presenters*.

3.3.2 Step 2: Make a presentation

Once you have started or joined a presentation group, you can make a presentation with the contents stored on your tablet, local network, or the Internet. There are three tabs in the lower left corner of the *NovoPresenter* home screen:



: Tap this tab to present an image stored on your tablet.



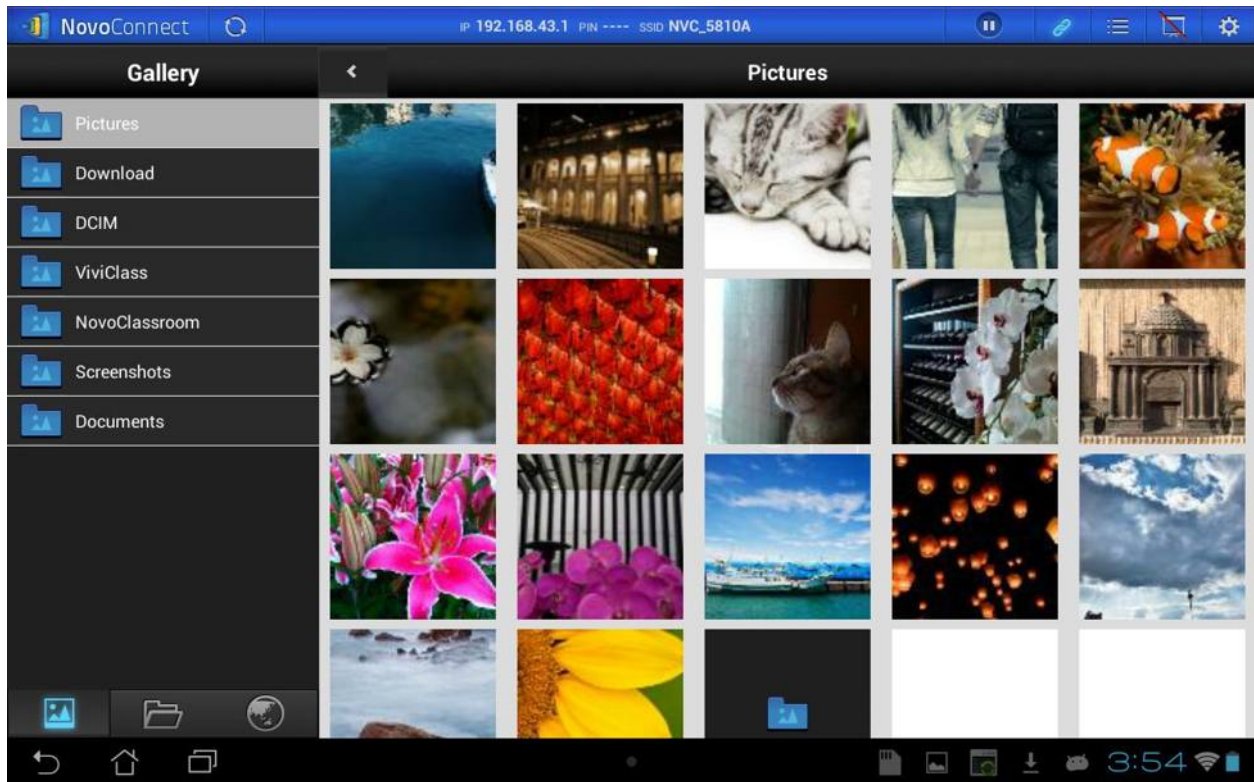
: Tap this tab to present a document stored on your tablet.





: Tap this tab to present a Web page.

3.3.2.1 Presenting an image

One quick way to import presentation files onto an Android tablet is to connect to a computer via USB cable. Drag and drop photos and documents onto the tablet as you would with a USB storage device. A sample screen is provided below.



(Note: *Education Edition* does not have the screen preview control tab  or the  symbol.)

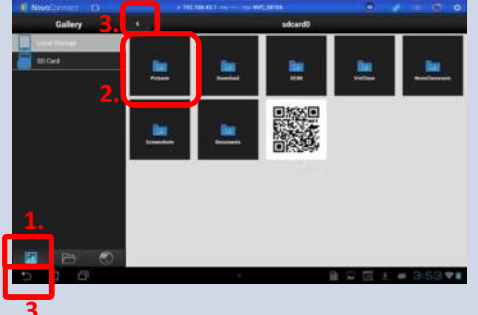



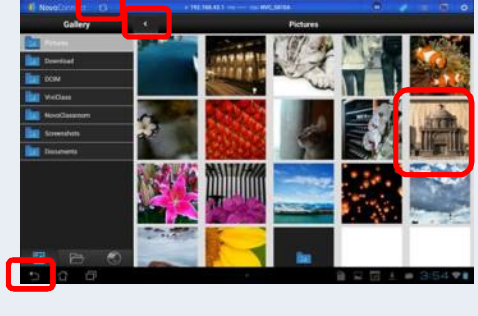



Function	Description
	<p>Navigation:</p> <ol style="list-style-type: none"> 1. Tap the  tab to access folders containing image files. It will light up blue. 2. Navigate to a folder by tapping the selected folder. 3. Tap the  tab or the back key  at any time to return to previous folder.
	<p>Image thumbnails:</p> <p>You will see image thumbnails displayed once you navigate to a folder with images. You can select a thumbnail to view the full image.</p> <p>Example: Tap the ancient building image thumbnail.</p> <p>Note: Tap the  tab or the back key  at any time to return to the previous folder. Tap the  tab at any time to refresh the screen.</p>



Image presentation:

The selected image will be displayed in full screen. You can zoom in on the image by sliding two fingers apart, or you can zoom out on the image by sliding two fingers toward each other.

If you have more than one image in the same folder, you can swipe your finger left or right on the screen to advance to the next or previous image.





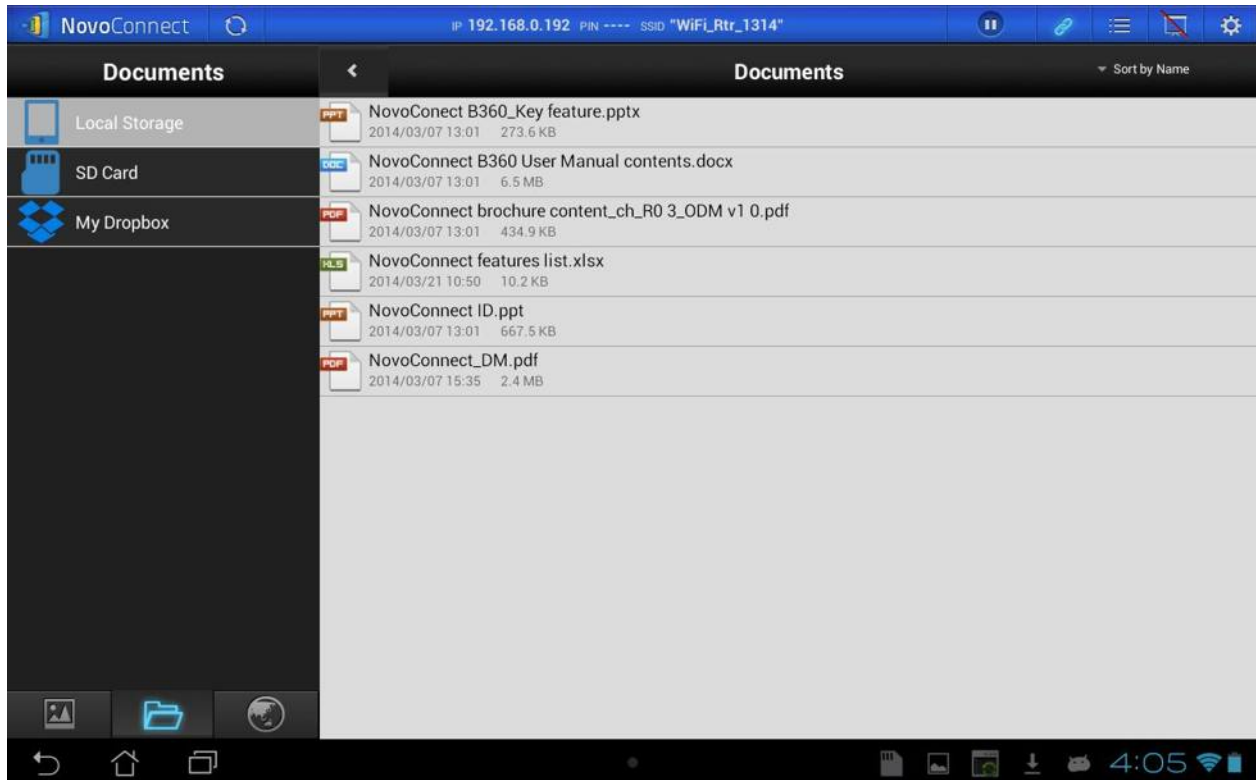
To return to the *Image Thumbnails* page, tap the  tab. To use the on-screen annotation tools, tap the  tab.





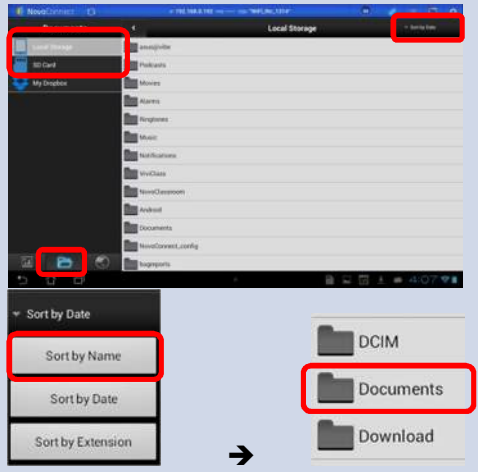






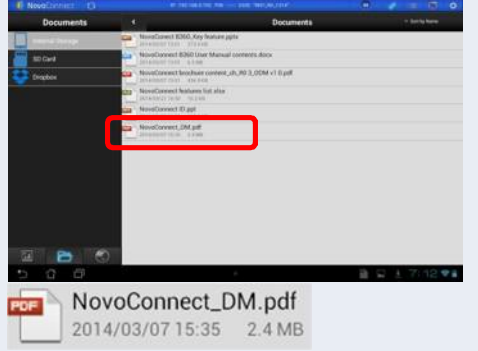



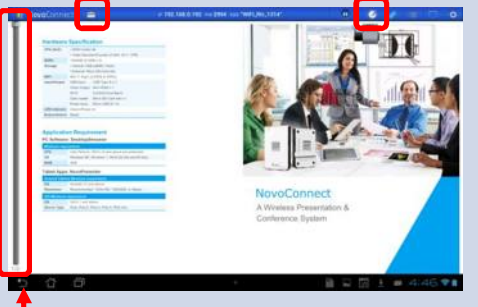

Image presentation control:

1. Tap any image area to show/hide the image presentation control items.
2. Tap  to rotate the image counterclockwise, or tap  to rotate the image clockwise.
3. To quickly select another image for presentation, drag the image thumbnail bar up or down, and then tap the image you wish to select.

3.3.2.2 Presenting a document (local storage)





(Note: *Education Edition* does not have the screen preview control tab  or the  symbol.)

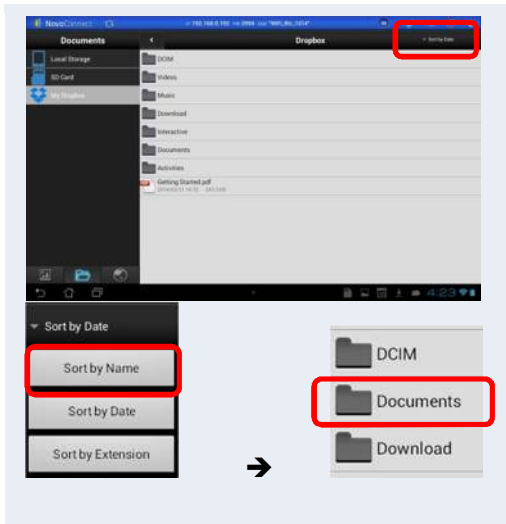
Function	Description
	<p>Navigation:</p> <p>Tap the  tab to access folders with supported document types. It will light up blue.</p> <p>Tap the  or  tab (or any other tab of your storage device) and browse a folder containing documents. If you wish to sort the folder list into a desired order, tap the drop-down menu Sort by..., then select one of the following options:</p> <ul style="list-style-type: none"> - Sort by Name - Sort by Date (default) - Sort by Extension <p>Example: Tap the Sort by... drop-down menu. Tap the option <i>Sort by Name</i>, and then tap the <i>Documents</i> folder.</p> <p>Note: You can tap the  tab or the back key  at any time to return to the previous folder. Also, you can tap the  tab at any time to refresh the screen.</p>
	<p>Document list:</p> <p>Once you enter a folder with documents supported by <i>NovoPresenter</i>, tap the desired document.</p> <p>Example: Tap the document “NovoConnect_DM.pdf”.</p> <p>Note: You can tap the  tab or the back key  at any time to return to the previous folder. Also, you can tap the  tab at any time to refresh the screen contents.</p>
 <p>Scroll Bar</p>	<p>Document presentation:</p> <p>The selected document (a PDF, for example) will be displayed in full screen. You can zoom in on the document by sliding two fingers apart, or you can zoom out of the document by sliding two fingers toward each other.</p> <p>To scroll down or move to the next page, slide your finger up or drag the scroll bar down. To scroll up or move to the previous page, slide your finger down or drag the scroll bar up.</p> <p>To return to the <i>Document List</i> page, tap the  tab. To use the on-screen annotation tools, tap the  tab.</p>

3.3.2.3 Presenting a document (with Dropbox)

To present with documents residing in Dropbox, please follow steps listed in the table below.

(Note: *Education Edition* does not have the screen preview control tab  or the  symbol.)

Function	Description
	<p>Set Your B360 to Client Mode: Set your B360's Wi-Fi mode to Client Mode and connect to a router with Internet access. Please refer to the <i>Remote Viewer</i> chapter for more details.</p>
	<p>Select Dropbox as the document source: Tap the folder tab . It will light up blue. Tap the  tab.</p>
	<p>First time using Dropbox in <i>NovoPresenter</i>: Upon first use of the <i>NovoPresenter</i> Dropbox feature, a link between <i>NovoPresenter</i> and your Dropbox account will need to be established. Choose a Web browser to access the Dropbox link page.</p>
	<p>Enter your Dropbox <i>Email</i> and <i>Password</i>, and then tap the Sign In button.</p>
	<p>Tap the Allow button to permit <i>NovoPresenter</i> to access your Dropbox documents. You will then be redirected back to <i>NovoPresenter</i>. Note: If your Android tablet is disconnected from your B360 during the Dropbox setup, simply reconnect to your B360 using the procedures in "<i>Step 2: Connect to your B360 device</i>".</p>






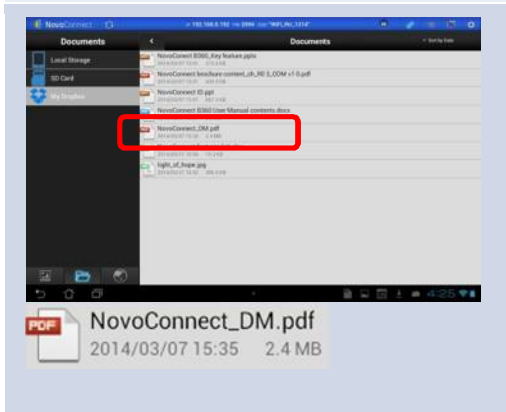
Navigation:

If you wish to sort the list into a desired order, tap the drop-down menu **Sort by...**, then select one of the following options:

- Sort by Name
- Sort by Date (default)
- Sort by Extension

Example: Tap the **Sort by...** drop-down menu. Tap the option *Sort by Name*, and then tap the *Documents* folder.



Note: You can tap the  tab or the back key  at any time to return to the previous folder. You can also tap the  tab at any time to refresh the Dropbox list.

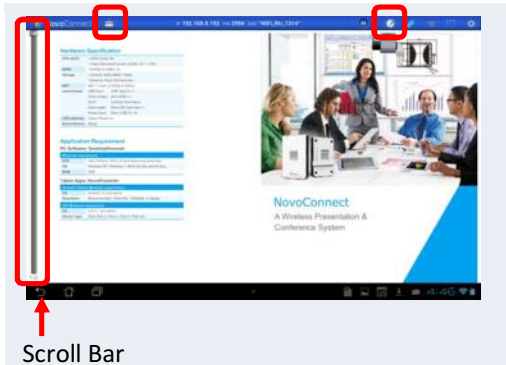


Document list:

Once you locate the desired document, you can open and present the document page by page on the Dropbox Web site without downloading the document to your Android tablet.


Example: Tap the document "NovoConnect_DM.pdf".

Note: You can tap the  tab or the back key  at any time to return to the previous folder.





Document presentation:

The selected document (the PDF in this example) will be displayed in full screen. If your presentation is paused, tap


the  button to resume the presentation. You can zoom in on the document by sliding two fingers apart, or you can zoom out of the document by sliding two fingers toward each other.

To scroll down or move to the next page, slide your finger up or drag the scroll bar down. To scroll up or move to the previous page, slide your finger down or drag the scroll bar up.



To return to the *Document List* page, tap the  tab. To use the on-screen annotation tools, tap the  tab.

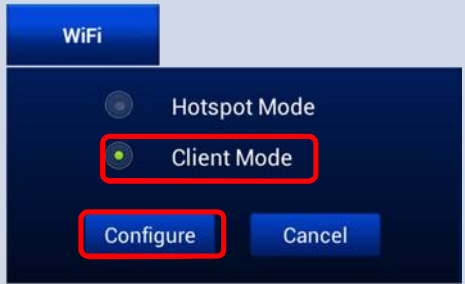
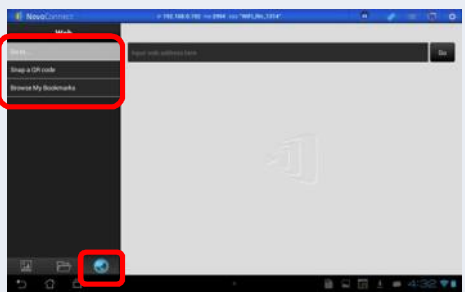



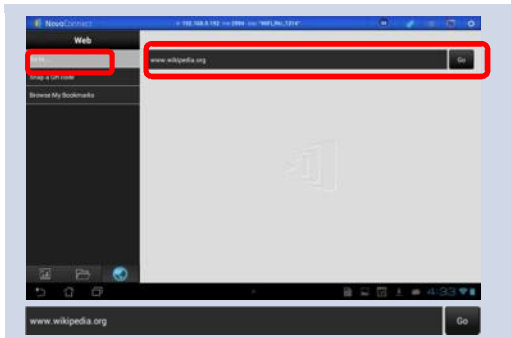
Unlink device from Dropbox:

If you need to unlink the *NovoPresenter* app from your Dropbox account, tap the  tab and tap **Unlink device from Dropbox**. When the “*Are you sure?*” confirmation dialog box appears, tap **Yes** to proceed.

3.3.2.4 Presenting a document (with a browser)

(Note: *Education Edition* does not have the screen preview control tab  or the  symbol.)

Function	Description
	<p>Set Your B360 to Client Mode: Set your B360's Wi-Fi mode to Client Mode and connect to a router with Internet access. Please refer to the <i>Remote Viewer</i> chapter for more details.</p>
	<p>Start browsing for a Web page: Tap the Internet tab . It will light up blue. Select one of the three options to access a Web page:</p> <ul style="list-style-type: none"> - Go to... (enter URL address [default]) - Snap a QR code - Browse My Bookmarks (Web site bookmarks)

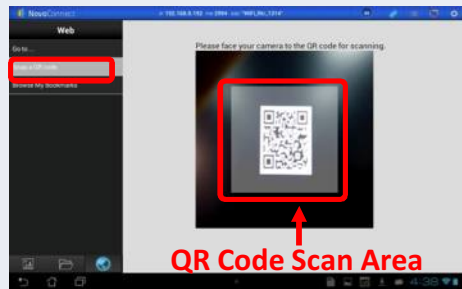


Go to ...:

Tap the **Go to ...** tab.

Enter the Web page URL and tap **Go**.

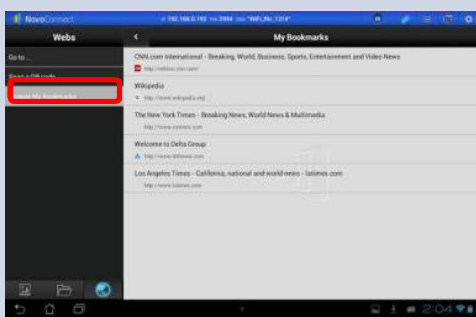
Example: Enter the URL www.wikipedia.org and tap **Go**.



Snap a QR code:

Tap the **Snap a QR code** tab.

Aim your tablet's camera at a QR code containing Web page information. *NovoPresenter* will detect the embedded URL and go to the corresponding Web page.




Browse My Bookmarks:

Tap the **Browse My Bookmarks** tab.

From the bookmark list, tap a bookmark of interest to go to its corresponding Web page.

Touch and hold a bookmark for two seconds to edit or delete that bookmark.


Note: The bookmark list may initially be empty. You can add a Web page to the bookmark list while browsing the Web by tapping the  tab.




Web page presentation:

The selected Web page will be displayed in full-screen. You can zoom in on the Web page by sliding two fingers apart, or you can zoom out on the Web page by sliding two fingers toward each other.

To scroll down or move to the next page, slide your finger up. To scroll up or move to the previous page, slide your finger down.



To add a Web page to the bookmark list, tap the  tab.

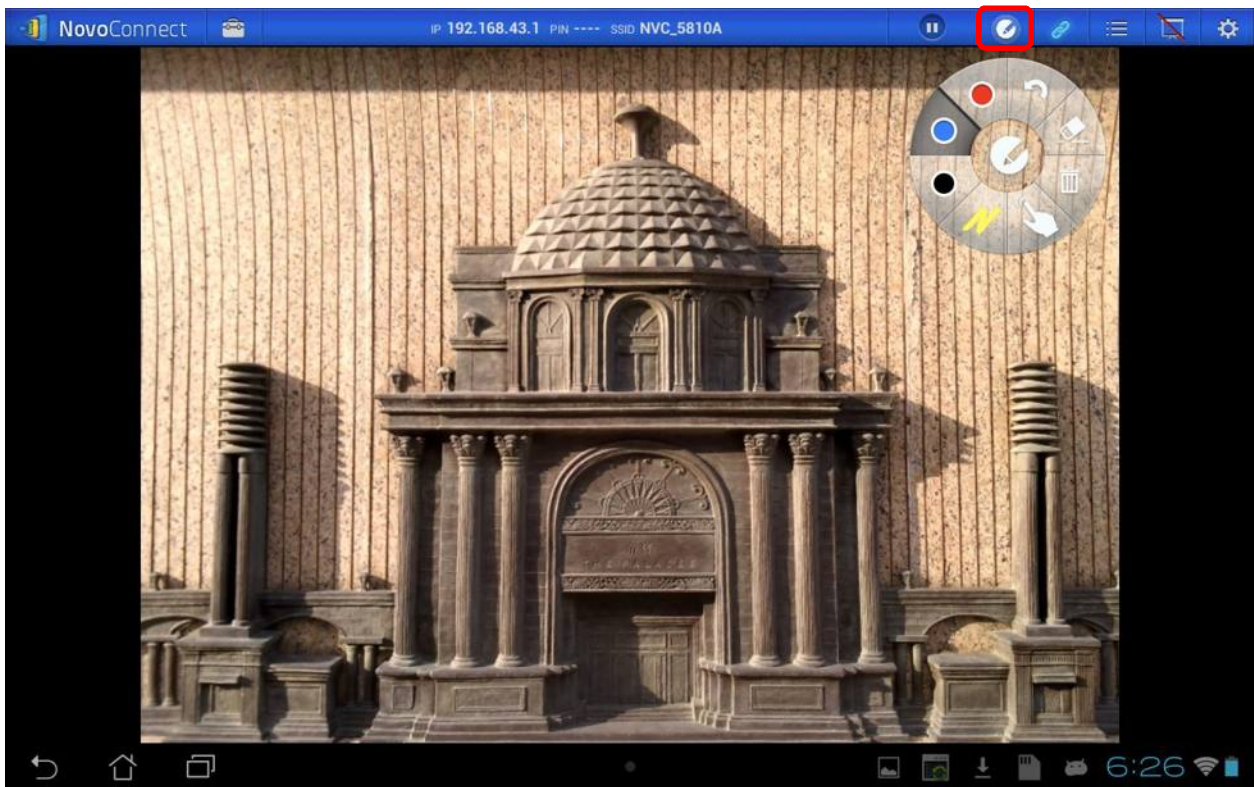
To return to **Browse My Bookmarks**, tap the  tab. To











use the on-screen annotation tools, tap the  tab.

3.3.2.5 Annotation

Sometimes you may want to write, highlight, or mark portions of your presentation materials directly on the tablet screen. *NovoPresenter* provides an on screen annotation tool for the presenter to annotate directly on the presentation material without changing the original. You

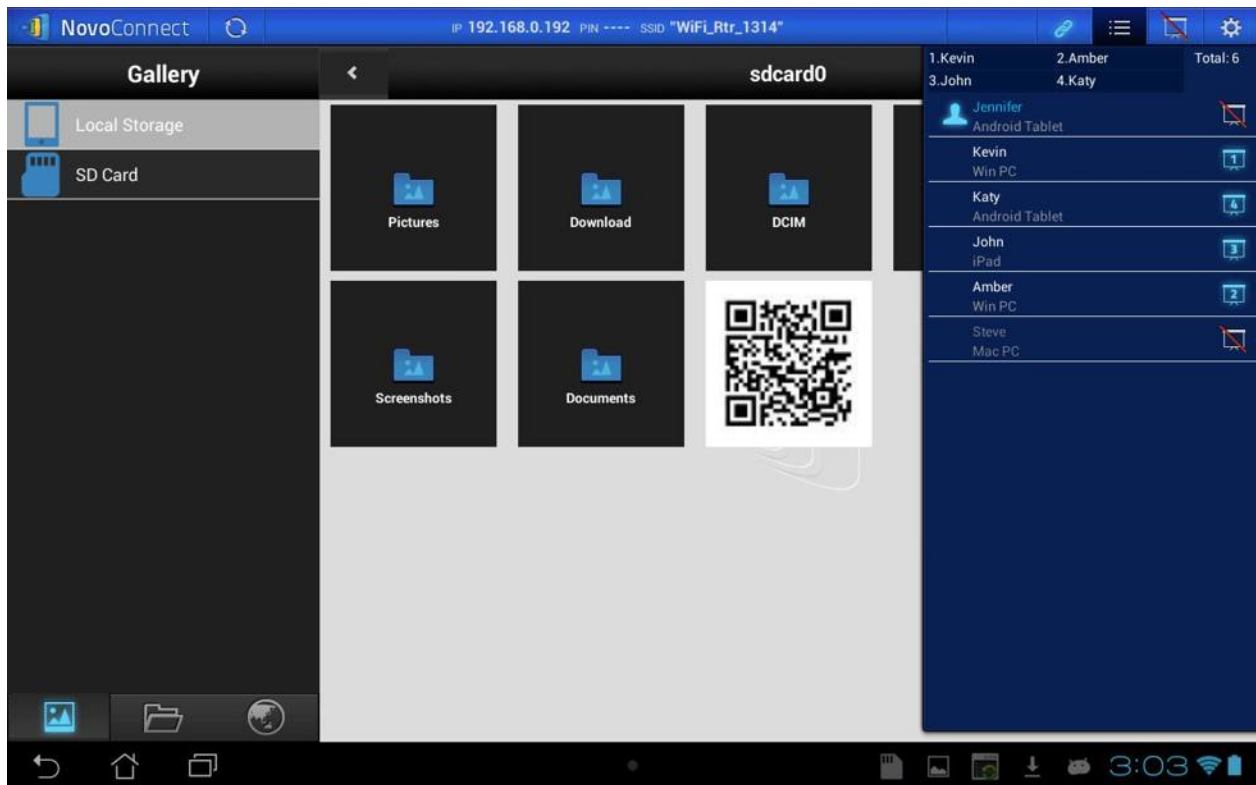
can enable the annotation tool  by toggling the  tab on, as shown in the screen sample below.



Function	Description
	<p>Touch the  tab to enable the annotation tool.</p> <ul style="list-style-type: none">  Annotate with a red marker  Annotate with a blue marker  Annotate with a black marker  Annotate with a yellow transparent marker  Change from annotation (writing) mode to touch panel (operation) mode  Trash can  Eraser  Undo


3.3.3 Step 3: Presentation management



Once you are done starting/joining a presentation group, you are ready to make a presentation and collaborate with other *participants*. A sample screen view is provided below.



3.3.3.1 Role assignment



There are three roles in a presentation group: the *host*, the *presenter*, and the *participant*. The first person to start the presentation group with a B360 is assigned the *host* role. Subsequent joiners are assigned the *participant* role. The *host* is defaulted to assume the *presenter* role until he hands over the *presenter* role to another *participant*.

To view all current *participants* who have joined the presentation group, tap the  tab.

(Note: *Education Edition* does not have the screen preview control tab  or the  symbol.)

Function	Description
	<p>Select the  tab to show <i>participant</i> list.</p> <p> indicates the current <i>host</i>.</p> <p> indicates the current <i>presenter</i>.</p> <p> *indicates a <i>participant</i> who has denied screen preview.</p> <p> indicates the current <i>presenter</i> that is presenting in the indicated split-screen box number (#1-4). The example here shows a <i>presenter</i> that is presenting in Box #1.</p> <p>*Example: There are six <i>participants</i> in the presentation group – two with Android tablets, two with Windows PCs, one with an iPad, and one with a Mac PC. Jennifer is the host who has automatically denied screen preview. Steve is a participant who has denied screen preview. Kevin, Amber, John, and Katy are <i>presenters</i> currently presenting in boxes #1-4 of the four-way split screen, which will be explained in detail later.</p> <p>*: For the <i>Education Edition</i>, there is no screen preview control tab , and all <i>participants</i> will automatically allow screen preview as  will not appear for any <i>participant</i>.</p>
	<p>The names on this box indicate the current <i>presenters</i> and the total number of current <i>participants</i>.</p> <p>Example 1: Oliver is the only <i>presenter</i>, and there are currently 2 <i>participants</i>.</p> <p>Example 2: Kevin, Amber, John, and Katy are the four <i>presenters</i>, and there are currently 6 <i>participants</i>.</p>
	<p>(For non-<i>host</i> users in <i>Corporate Edition</i> only) Toggle between  and  to accept or deny screen preview by the <i>host</i>, respectively.</p>



3.3.3.2 Role change, screen preview, and four-way split screen



(Note: *Education Edition* does not have the screen preview control tab  or the  symbol.)

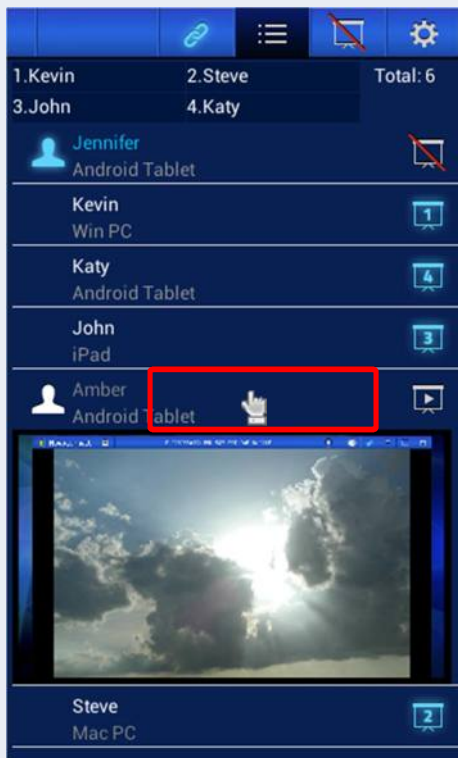
Function	Description
	<p>To perform a role change:</p> <p>First select the  tab to show the <i>participant</i> list.</p>
	<ol style="list-style-type: none"> 1. Highlight <i>participant</i> John by tapping the middle part of the entry of John once or twice until both the  and the  icons appear. 2. Tap John's  icon to hand over the <i>host</i> role to him. 3. If the split screen selection area  is not yet present, tap the  icon to bring up the split screen selection area. 4. Tap the  icon of the split screen selection area to request that John be the sole <i>presenter</i>. 5. Tap one of the four boxes (#1-4) in the split screen selection area to assign John to perform a presentation on one of the four boxes of the four-way split screen.
	<p>When a <i>participant</i> is asked to be a <i>host</i> or a <i>presenter</i>, a dialog box will appear on the <i>participant's</i> screen to request confirmation.</p> <p>The <i>participant</i> has 20+ seconds to tap the Yes button to accept the new role or tap the No button to reject.</p>





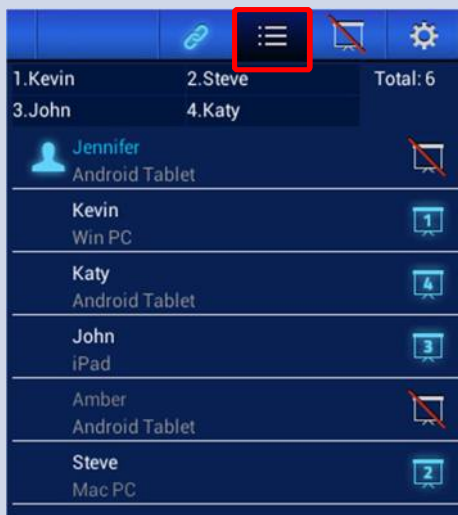
To perform screen preview:

Tap the  tab to show the *participant* list.
 The *participant* Amber does not have an  icon, indicating that she allows screen preview. *


*For *Education Edition*, there is no screen preview control tab , and all *participants* will automatically allow screen preview as  will not appear for any *participant*.

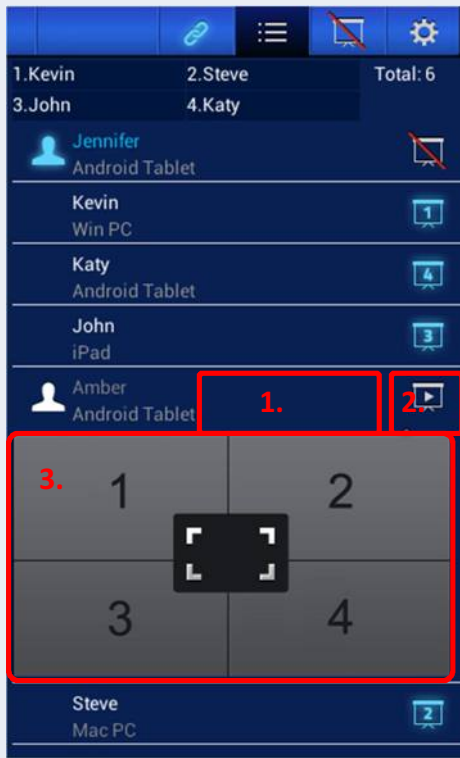


To preview a *participant's* screen, tap the middle part of an entry once or twice to bring up both the  and the  icons. Wait a few seconds for the screen to be sampled and displayed. In this example, Amber's Android tablet is selected to be previewed.



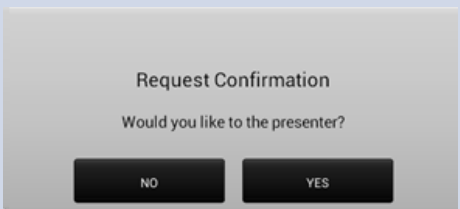
To perform a four-way split screen presentation:

Tap the  tab to show the *participant* list.
 Select a *participant* to make a presentation. In this example, Amber is selected.



Four-way split screen presentation:

1. Tap Amber's entry once or twice until both the and the icons appear.
2. If the split screen selection area is not yet visible, touch the icon to bring up the split screen selection area.
3. Tap one of the four boxes (#1-4) in the split screen selection area to assign Amber to perform a presentation on one of the four boxes of the four-way split screen.

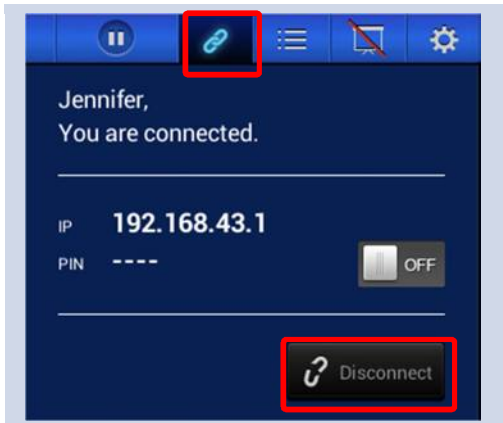


Amber will receive a request to perform a presentation in one of the four boxes of the four-way split screen. After Amber accepts (within 20+ seconds) the request by tapping the **Yes** button, Amber's screen will appear on one of the four boxes of the four-way split screen.


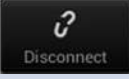
3.3.3.3 Pause, resume, and disconnect

(Note: *Education Edition* does not have the screen preview control tab or the symbol.)

Function	Description
	<p>To Pause a presentation:</p> <p>Tap the tab to enter the presentation control page.</p>
	<p>Pausing and resuming a presentation:</p> <p>While presenting, toggle between and to pause and resume the presentation respectively.</p>





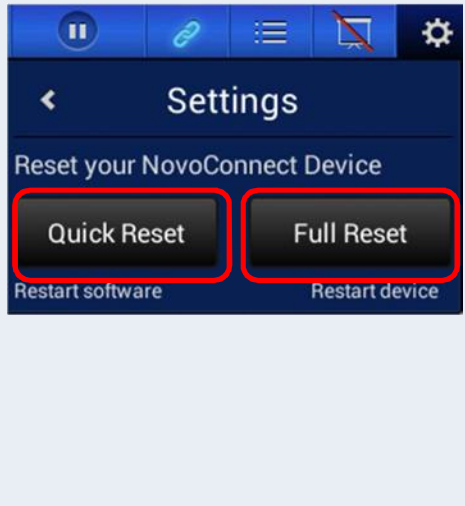
To Disconnect from a presentation group:

1. Tap the  tab to enter the presentation control page.
2. Tap the  button to exit the presentation group.

If the *host* exited the presentation session without handing over the *host* role, all *participants* will receive a message prompting them to take over the *host* role. The first to respond to the prompt will assume the role of the *host*.

3.3.3.4 Reset and rename local device

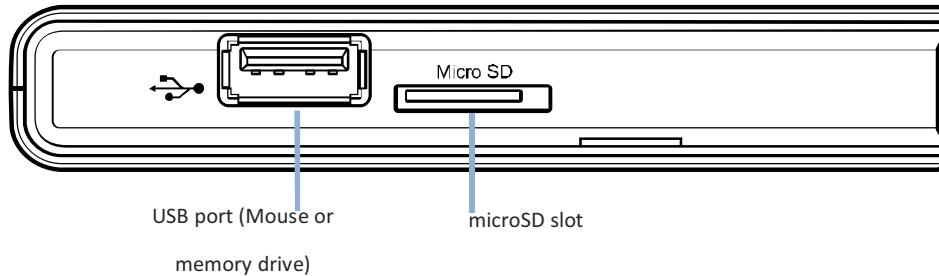
Occasionally you may encounter problems with the network or the computer, causing the presentation group to malfunction on your B360. One way to resolve this problem is to reset the presentation group.

Function	Description
	<p>To perform a Reset:</p> <p>First tap the  tab and tap the  arrow of Device's Reset.</p>
	<p>Resetting:</p> <p>Tap Quick Reset to start a presentation group. Tap the Full Reset button to reset the NovoConnect B360 device. The B360 device will restart automatically. Conflicts may occur when multiple <i>participants</i> simultaneously attempt to reset the presentation group or the B360. The reset privilege priorities are as follows:</p> <ol style="list-style-type: none"> 1. <i>Host</i>: The <i>host</i> has the sole privilege to quick-reset the presentation group or the B360 when the <i>host</i> stays connected to the B360. 2. <i>Presenter</i>: If the <i>host</i> loses connection with the B360, the current <i>presenter</i> inherits the privilege to quick-reset the B360. 3. <i>Participant</i>: If the <i>host</i> and the <i>presenter</i> both lose connection with the B360, any <i>participant</i> can quick-reset the presentation group.

3.4 Presenting with the NovoConnect B360 Device

Your B360 device allows you to make presentations with the computing power of the device itself without the assistance of a computer. Your presentation files may reside in a microSD card, USB memory drive, the internal storage of your B360 device, or in your Dropbox online storage account (Internet connection required for Dropbox access).

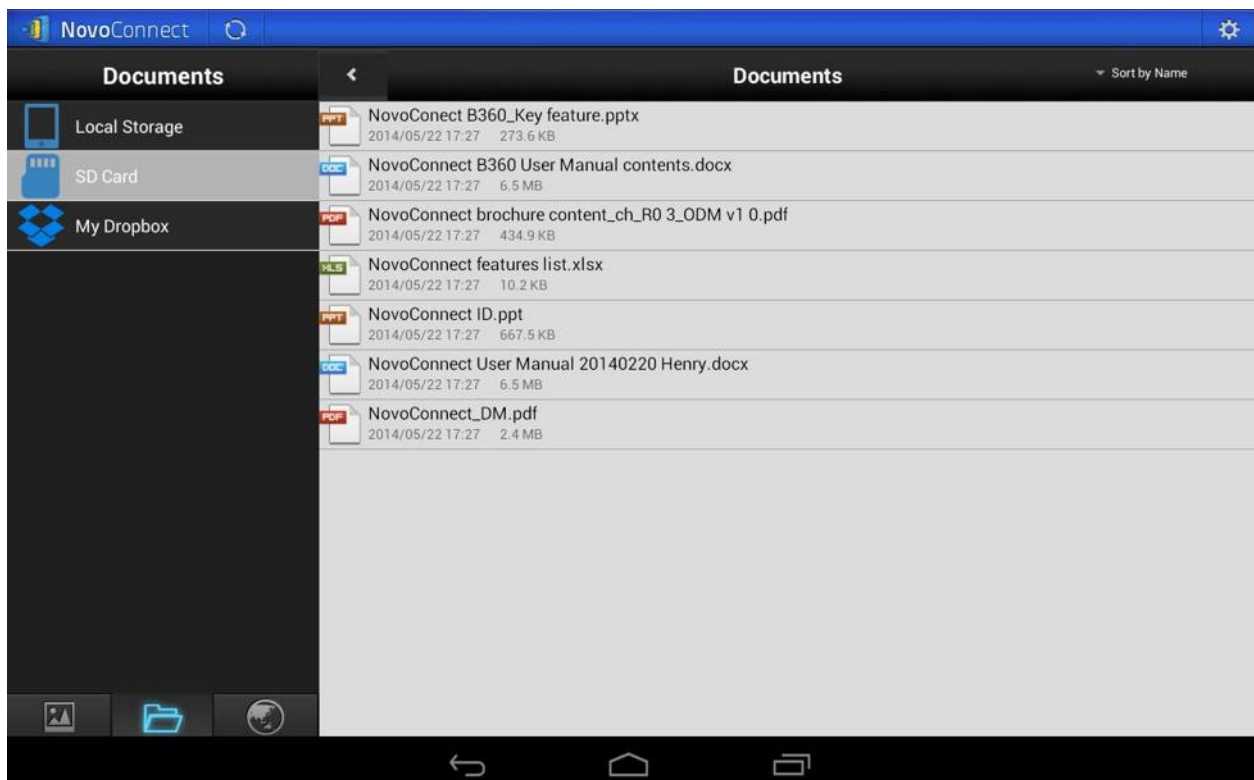
The steps for making a presentation with only your B360 are as follows:



- 1) If your presentations are stored on a microSD card, please insert the microSD card into the microSD card slot.
- 2) If your presentations are stored on a USB memory drive, please first connect a USB hub to your B360 device, then connect a mouse and a USB memory drive to the USB hub.
- 3) You can also save your presentation files in the local storage of your B360 or in your Dropbox online.

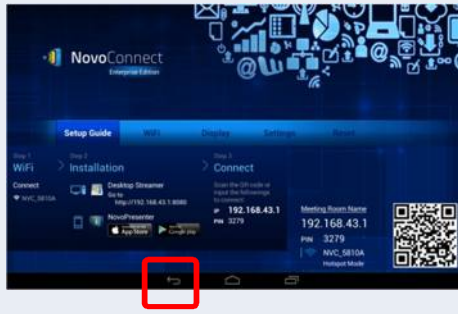
Note: You need a USB mouse to operate the following steps.

You are now ready to make a direct presentation with your B360.




The following table shows detailed steps on how to make a direct presentation:

Function	Description
	<p>To present directly with your B360: Click an empty space of the NovoConnect home screen. Then click the home button .</p>
	<p>To present directly with your B360: Click the apps button .</p>
	<p>To present directly with your B360: Click <i>NovoPresenter</i> .</p>
	<p>To present directly with your B360: Please go to the section 3.3.2 Step 2: Make a Presentation for more details on making a presentation with <i>NovoPresenter</i>. Ignore instructions for Snap a QR Code.</p>
	<p>To return to Remote Viewer: Click the back key  one or more times until <i>NovoPresenter</i> disappears.</p>
	<p>To return to Remote Viewer: Click <i>Remote Viewer</i>  (Note: If you do not see the app list as shown on the left, click the home button , next click the apps button , and then click <i>Remote Viewer</i> .</p>



To return to *Remove Viewer*:



Click the back key  one or more times until the system bar disappears.

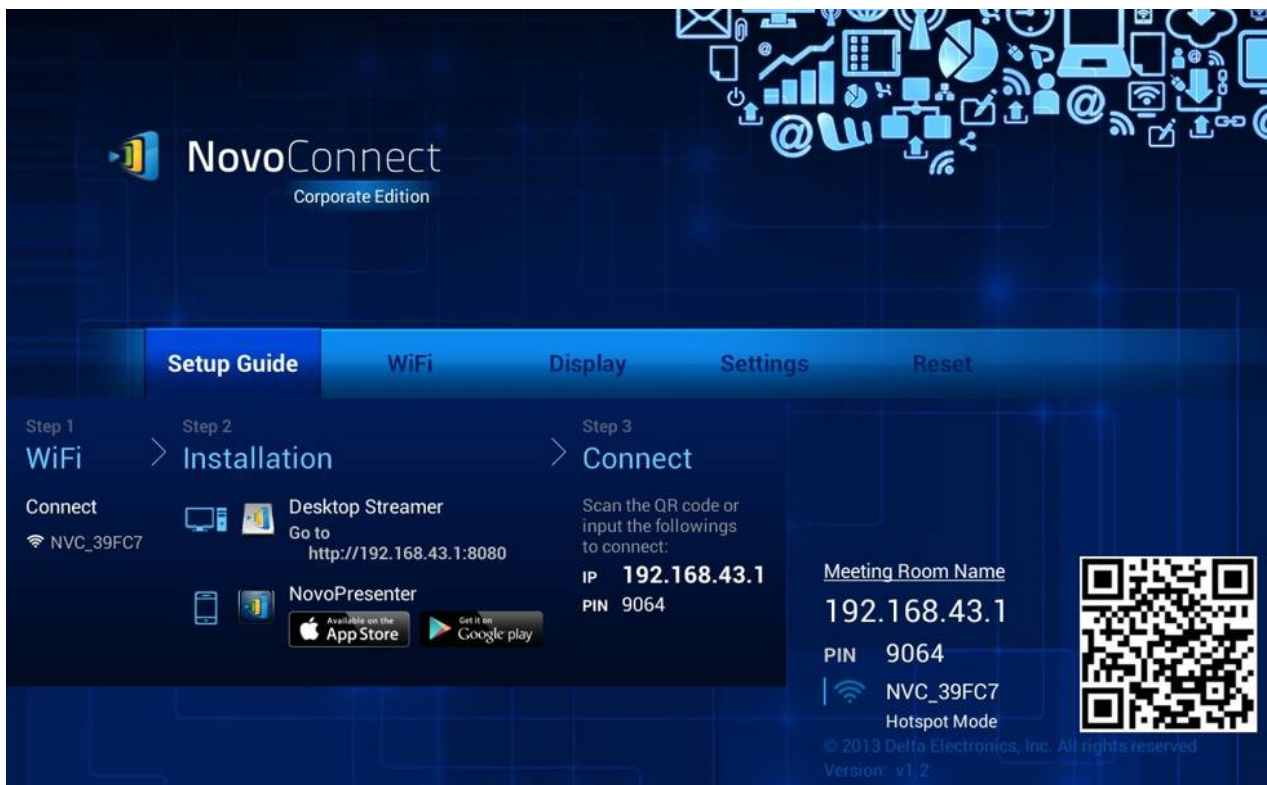
4. B360 Configuration

4.1 B360 System Configuration

Remote Viewer is the application software on the NovoConnect B360 device that hosts the presentation group. The main function of *Remote Viewer* is to manage and control all presentation sessions between the *participant* devices and the NovoConnect B360. In addition to presentation management, *Remote Viewer* supports the configuration of the following parameters on the B360 device:


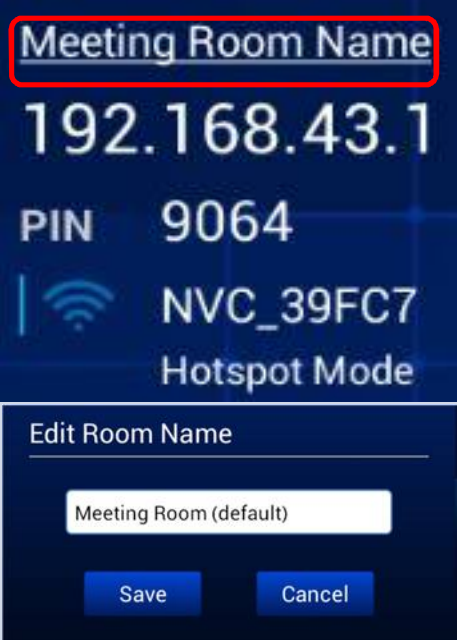



- Setup Guide
- Wi-Fi
- Display
- Settings
- Reset
- Presentation Group Name

Note: Following any clicking activity on the screen, the system bar  appears. Click the back key  one or more times until the system bar disappears.



Please go to the NovoConnect home screen to locate the parameters. You will need a USB-based mouse to perform setting changes.

Function	Description						
	<p>Setup Guide and QR Code:</p> <p>The B360 connection setup guide is initially selected when B360 is first powered on. To show or hide this guide, click Setup Guide. For quick connection with iPad or Android tablets, the B360 connection QR code is continuously displayed and updated on the lower right corner of the NovoConnect home screen.</p> <p>For more details regarding the use of this setup guide and the QR code, please refer to the section 1.2.2 The NovoConnect Home Screen earlier in this document.</p>						
	<p>Wi-Fi:</p> <p>Click the WiFi button to bring up the Wi-Fi configuration window.</p> <p>To use the B360 as the Wi-Fi host, select Hotspot Mode and click Apply.</p> <p>To use an external router as the Wi-Fi host with Internet access, select Client Mode; click Configure to bring up the relevant Android system menu. Enable Wi-Fi connection. Select the SSID of the external router. Enter the router's password if needed. Click Connect.</p>						
	<p>Display:</p> <p>Click the Display button to bring up the <i>Select Display Output Format</i> window.</p> <p>Select one of the following screen resolutions (the <i>presenter's</i>, Windows and Mac PC, will be automatically adjusted to match the selected option):</p> <table border="1" data-bbox="687 1332 1396 1512"> <tr> <td>Auto Config</td> <td rowspan="5">This setting automatically determines the optimal screen resolution.</td> </tr> <tr> <td>XGA(1024x768)</td> </tr> <tr> <td>WXGA(1280x800)</td> </tr> <tr> <td>720p (1280x720)</td> </tr> <tr> <td>1080p (1920x1080)</td> </tr> </table> <p>Click Save to confirm the selection, or click Cancel to abort the selection.</p>	Auto Config	This setting automatically determines the optimal screen resolution.	XGA(1024x768)	WXGA(1280x800)	720p (1280x720)	1080p (1920x1080)
Auto Config	This setting automatically determines the optimal screen resolution.						
XGA(1024x768)							
WXGA(1280x800)							
720p (1280x720)							
1080p (1920x1080)							
	<p>Settings:</p> <p>For more device settings for your B360, click the Settings button to access the Android system menu.</p>						



	<p>Reset: To restart the NovoConnect B360: Press and hold on the Reset tab for two (2) seconds. The B360 will restart.</p>
	<p>Presentation group name: Click on the presentation group name shown in the lower right corner of the NovoConnect home screen. This will bring up the <i>Edit Room Name</i> window. Enter the new presentation group name using the on-screen soft keyboard. Click Save to confirm the name change, or click Cancel to abort the name change.</p>
	<p>Set edition: Click on the edition name shown on the top left corner of the NovoConnect home screen. This will bring up the edition selection window. Select either Corporate Edition or Education Edition, then click Confirm to make the edition change official, or click Cancel to abort the edition change. The main difference between these two editions are as follows:</p>
	<p>Corporate Edition: The <i>host</i> must obtain permission from <i>participants</i> for screen preview.</p>
	<p>Education Edition: The <i>host</i> can preview the screen of any <i>participant</i> without requiring permission. For all users that are connected to the B360 device, there is no screen preview control tab , and all <i>participants</i> will automatically allow screen preview as  will not appear for any <i>participant</i>.</p>



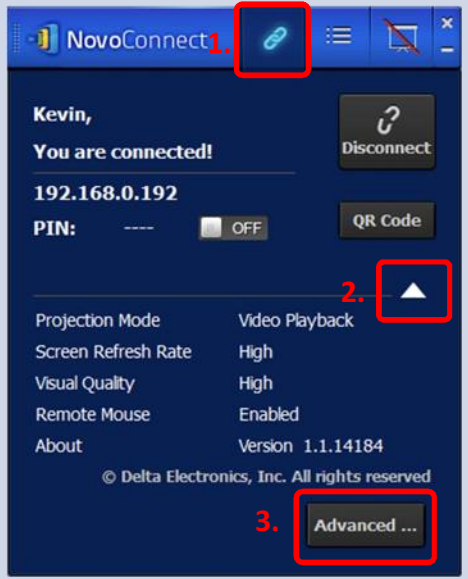


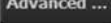
4.2 Device information and settings, reset, and firmware upgrade

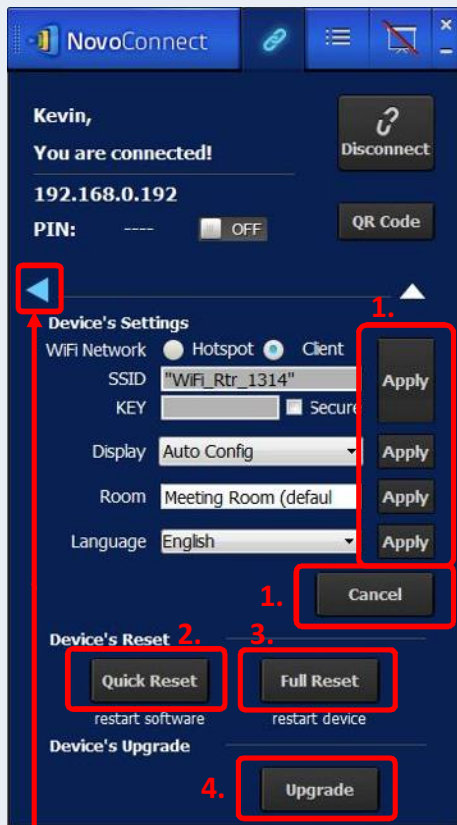
The device information and settings menus have four functions:

1. **Presentation Settings:** This screen displays presentation connection information for your B360.
2. **Device Settings:** These options allow you to remotely configure your B360 from your desktop.
3. **Reset:** Occasionally you may encounter problems with the network or computer, causing the presentation group to malfunction on your B360. This button allows you to reset the presentation group to help resolve such problems.
4. **Device Upgrade:** This option allows you to upgrade your B360 online to the latest firmware version.

Follow the steps below to access the functions described above.

(Note: *Education Edition* does not have the screen preview control tab  or the  symbol.)

Function	Description
	<p>To show presentation settings (when disconnected): Click  to expand the Settings tab to access more detailed settings.</p>
	<p>To show presentation settings (when connected):</p> <ol style="list-style-type: none"> 1. Click the  tab to enter the presentation control page. 2. Click the  icon to display presentation settings that have been set before connecting to your B360. 3. Click  to access the device settings, reset, and device upgrade function as shown below.



Click this tab to go back to the presentation settings page.

Configuring device settings (when connected):

Here you can remotely configure your B360 device settings right from your desktop.

1. Click **Apply** to confirm the changes, or click **Cancel** to abort the changes.

Resetting your NovoConnect device:

2. Click **Quick Reset** to reset the presentation group to allow it to start over.
3. Click **Full Reset** to restart the NovoConnect B360 device.

Conflicts may occur when multiple *participants* simultaneously attempt to reset the presentation group or the B360 device.

The reset privilege priorities are as follows:

- a) *Host*: The *host* has the sole privilege to reset the presentation group or the B360 when the *host* stays connected to the B360.
- b) *Presenter*: If the *host* lost connection with the B360, the current *presenter* inherits the privilege to reset the presentation group or the B360.
- c) *Participant*: If the *host* and the *presenter* both lose their connection with the B360, any *participant* can reset the presentation group or the B360.

Upgrading the NovoConnect firmware:

First make sure that your B360 is set to *Client Mode* and is connected to a Wi-Fi router with an Internet connection.

4. Click **Upgrade**. The computer will automatically check for the latest firmware upgrade for your device. If new upgrades are available, your B360 will automatically download and install them.

5. Specifications

Hardware Specifications	
Power Supply	5VDC, 2A
Power Consumption	< 10W
Output Resolutions	1024x768 (XGA), 1280x720 (HD), 1280x800 (WXGA), 1920x1080 (Full HD), Auto Config
CPU (SoC)	ARM Cortex A9 Video Decoder/Encoder (H.264, VC-1, VP8)
Memory	DDR 1024MB
Storage	Internal: 4GB (eMMC Flash) External: microSD Card Slot
Wi-Fi	802.11 b/g/n (2.4GHz & 5GHz)
Input/Output	USB Input USB Type A x 1 Video Output Micro HDMI x 1 Card Reader microSD Card Slot x 1 Power Input Micro USB (5V 2A)
LED Indicator	Green (Power On)
Button/Switch	Reset
Dimensions	88 x 55 x 16 mm (L x W x H)
Weight	105 g
PC/Notebook Application Requirements	
CPU	Intel Pentium, 2GHz (Intel Core i3 and above are preferred)
Operating System	Windows XP, Windows 7, Windows 8 (32 bits and 64 bits), Mac 10.6 and above
RAM	4 GB
Android Mobile Device Application Requirements	
Operating System	Android 3.2 and above (Android 4.0 and above are recommended)
Resolution	1024x768, 1280x800, or higher are recommended
iOS Mobile Device Application Requirements	
Operating System	iOS 5.1 and above
Device Type	iPad, iPad 2, iPad 3, iPad 4, iPad mini, and iPad Air

6. Troubleshooting

Q: NovoConnect does not power up or operate.

A: Check if the proper DC power supply with the appropriate operating voltage and sufficient operating current (5VDC, 2A) is connected to the Micro-USB port of the NovoConnect B360.

Q: My PC cannot link to NovoConnect wirelessly.

A: For your PC to link to NovoConnect, your PC must either have a built-in a Wi-Fi module or an external Wi-Fi adapter, and Wi-Fi must be enabled. If the NovoConnect B360 is set to Hotspot Mode (factory default mode), choose NovoConnect's SSID from the available SSID list. If NovoConnect is set to Client Mode and is connected to a specific Wi-Fi AP, choose that AP's SSID from the available SSID list.

Q: The play/pause buttons do not work.

A: These buttons are functional only for the current *presenters*.

Q: I cannot connect to the Internet on NovoConnect.

A: This is normal if the NovoConnect B360 is set to Hotspot Mode, since NovoConnect by itself does not support WAN (wireless wide area network) access. To access the Internet for tasks such as Web browsing on NovoConnect, please set the Wi-Fi to Client Mode and connect to a Wi-Fi AP that that is connected to the Internet.

Q: My PC or mobile device has failed to connect to NovoConnect.

A: First, make sure that Wi-Fi is enabled on your device. If NovoConnect is set to Hotspot Mode (factory default mode), choose the NovoConnect's SSID from the available SSID list. If NovoConnect is set to Client Mode and is connected to a Wi-Fi router, choose that router's SSID from the available SSID list.

Q: I cannot choose to present in full screen or in one of the split screens.

A: Only the *host* has the authority to decide whether your presentation is to be seen in full screen or one of the split screens. You may be invited to be the *host*: 1) if the Reset button is clicked on the NovoConnect B360, 2) if the *host* explicitly hands over *host* control to you, or 3) if all other *presenters* have disconnected from NovoConnect.

Q: I am the *host*, but I cannot preview other *participants'* screens.

A: To preview a *participant's* screen before sending a presentation invitation, that *participant* must have screen preview enabled on his device.

Q: My device's on-screen display looks stretched or compressed on NovoConnect's screen output.

A: There may be an aspect ratio mismatch between the NovoConnect B360's chosen output resolution and your device's screen aspect ratio (e.g. your device's screen has the 4:3 aspect ratio, and you have set NovoConnect's output resolution to a 16:9 or 16:10 option). Try to set the display resolution on the NovoConnect B360 so that it has an aspect ratio that either matches that of your device or is as close to your device's screen aspect ratio as possible. You have the option of letting NovoConnect automatically determine the best output resolution by selecting Auto Config in the display settings.

Q: During the presentation, my PC/Mac computer's cursor is flickering.

A: You can try a different screen resolution for your PC/Mac computer. You can also try different settings for Projection Mode, Visual Quality, and Screen Refresh Rate (which need to be set before you connect your PC/Mac computer to your NovoConnect B360) until the problem disappears or is minimized.

7. Safety Information

Refer to the manual and take note of the safety instructions before operating your device.

- Ensure that the power source's output voltage matches your device's operating voltage.
- To prevent the risk of electric shock, do not operate this device near water or in environments of high moisture.
- Do not disassemble or try to repair this device by yourself. Contact your local Delta service center for assistance.
- Keep the device's plastic packages out of the reach of children.

8. Copyright Information

Copyright 2013 Delta Electronics, Inc. All Rights Reserved.

Android and Google are registered trademarks of Google Inc.

ARM is a registered trademark of ARM Inc.

App Store, iPad, iTunes, Mac, and Mac OS are service marks, trademarks, or registered trademarks of Apple Inc.

IOS is a trademark or registered trademark of Cisco in the U.S. and other countries and is used under license.

miniSD, microSD, miniSDHC, microSDHC, microSDXC, smartSD, smartSDHC, SDIO and miniSDIO are all trademarks or registered trademarks of SD-3C, LLC in the United States, other countries or both.

Microsoft and Windows are either trademarks or registered trademarks of Microsoft Corporation in the United States and/or other countries.

Pentium and Core i3 are registered trademarks of Intel Corporation.

VGA and XGA are registered trademarks of International Business Machines Corporation.

Product names, logos, brands, and other trademarks featured or referred to in this materials are the property of their respective trademark holders.

9. Index

1. access point
2. Android
3. B360
4. cable
5. click
6. Client Mode
7. configure
8. connect
9. device
10. disconnect
11. Dropbox
12. firmware upgrade
13. HDMI
14. host
15. Hotspot Mode
16. icon
17. install
18. internet
19. iOS
20. iPad
21. IWB
22. join
23. keyboard
24. login
25. Mac
26. mobile
27. mouse
28. NovoConnect
29. NovoConnect Desktop Streamer
30. NovoPresenter
31. PC
32. PIN
33. participant
34. power
35. presentation
36. presenter
37. preview
38. projector
39. QR code
40. reset
41. Remote Viewer
42. resolution
43. role
44. screen
45. setting
46. software
47. SSID
48. tablet
49. touch
50. USB
51. Wi-Fi
52. Windows