

Delta Ventilation Fans

VFB100BTH

Features

- ▲ High Efficiency Brushless DC Motor
- ▲ Low Power Consumption
- ▲ Low Noise Design
- ▲ Long Life Ball Bearings
- ▲ UL 94-V0 Flammability Resin
- ▲ Soft Start Control
- ▲ Locked Protection
- ▲ Easy Installation & Maintenance



Application

Bathroom & Bedroom / Dining Room & Living Room /
Meeting Room / Office

Dimensions unit: mm

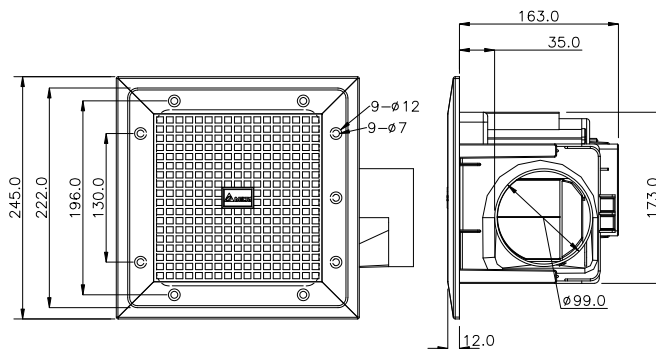

P&Q Curve

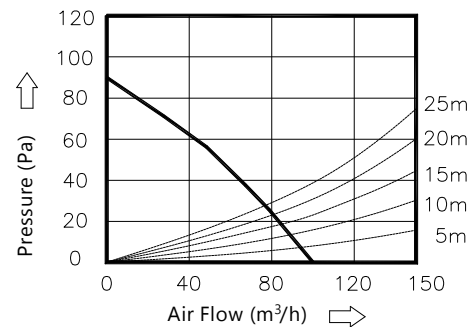

Specifications

| Model | Grille Size | Install Size | Duct Size | Weight | Nominal Voltage | Input Power | Maximum Airflow | Maximum Air Pressure | Noise | Remark | | |
|-----------|-------------|--------------|-----------|--------|-----------------|-------------|-------------------|----------------------|-------|--------|------|-----|
| PART NO. | mm | mm | mm | kg | VAC | Watt | m ³ /h | CFM | Pa | inAq | dB-A | --- |
| VFB100BTH | 245X 245 | 175 X 175 | 100 | 1.35 | 220/50 | 6.0 | 100 | 58.9 | 90 | 0.36 | 33 | |

- * The max. air flow is measured in free air; the max. air pressure is measured at zero air flow.
- * Noise is measured in semi-anechoic chamber in free air, one meter from intake, right and left side, 3 microphones to average.
- * All readings are typical values at rated voltage.
- * Specifications are subject to change without notice.