

The power behind competitiveness

Delta UPS - Amplon Family

RT Series, Three Phase
10/ 15/ 20 kVA
Power Distribution Box
for Single UPS/ Parallel UPSs

User Manual

SAVE THIS MANUAL

This manual contains important instructions and warnings that you should follow during the installation, operation, storage and maintenance of this product. Failure to heed these instructions and warnings will void the warranty.

Copyright © 2020 by Delta Electronics Inc. All Rights Reserved. All rights of this User Manual ("Manual"), including but not limited to the contents, information, and figures are solely owned and reserved by Delta Electronics Inc. ("Delta"). The Manual can only be applied to the operation or the use of this product. Any disposition, duplication, dissemination, reproduction, modification, translation, extraction, or usage of this Manual in whole or in part is prohibited without the prior written permission of Delta. Given that Delta will continuously improve and develop the product, changes may be made to the information in this Manual at any time without obligation to notify any person of such revision or changes. Delta will make all possible efforts to secure the accuracy and the integrity of this Manual. Delta disclaims any kinds or forms of warranty, guarantee, or undertaking, either expressly or implicitly, including but not limited to the completeness, faultlessness, accuracy, non-infringement, merchantability or fitness for a particular purpose of the Manual.

Table of Contents

Chapter 1: Product Introduction.....	p. 3
Chapter 2: Important Safety Instructions	p. 4
Chapter 3: Package List	p. 6
Chapter 4: Appearance, Dimensions & Panels	p. 8
Chapter 5: Installation.....	p. 13
Chapter 6: Connection.....	p. 16
Chapter 7: Operation Procedures.....	p. 34
Chapter 8: Maintenance Bypass	p. 35
Appendix 1: Technical Specifications.....	p. 40
Appendix 2: Warranty	p. 42

Chapter 1 : Product Introduction

The Delta Power Distribution Box (PDB) with 3U in height is applicable to the Delta Amplon UPSs: RT-15K3P and RT-20K3P. The PDB can be connected to single UPS or two parallel UPSs and can be configured into single-phase/ three-phase output to suit your needs. The PDB provides AC input power to the UPS and connects the output of the UPS to the critical loads. When your UPS needs maintenance, you can switch on the PDB's manual bypass switch to let the power be transferred from the inverter output to the manual bypass output to ensure continuous power supply to your critical loads during the UPS maintenance.

The PDB also provides four IEC-320 C13 outlets and two IEC-320 C19 outlets to meet your power distribution needs.

Chapter 2 : Important Safety Instructions

2.1 Safety Instructions

Installation Warnings

- Before installation and usage, please read this **User Manual** thoroughly. This helps you to use the product correctly and safely.
- Install the PDB in a well-ventilated area, away from excess moisture, heat, dust, flammable gas or explosives.
- To avoid fire accidents and electric shock, please install the PDB in an indoor area free of conductive contaminants and the temperature and humidity must be well-controlled. For the temperature and humidity specifications, please refer to **Appendix 1: Technical Specifications**.
- Leave adequate space (at least 50 cm (1.97")) at the front and rear of the PDB for proper ventilation.

Connection Warnings

- The PDB must be well grounded due to a possible risk of current leakage.
- It is necessary to connect the protection devices with the PDB when the PDB is connected to power sources and critical loads.
- The protection devices connected to the PDB must be installed near the PDB and must be easily accessible for operation.
- If you need to move the PDB or perform re-wiring, please turn off the AC input power. Otherwise, the output end might still be energized, which might cause electric shock.

Usage Warnings

- To ensure reliable operation of the PDB and to protect the PDB from overheating, the slits and openings in the PDB must not be blocked or covered.
- Before usage, you must allow the PDB to adjust to room temperature for at least one hour to avoid moisture condensing inside the PDB.
- Do not pour and splash any liquid on the PDB. Do not insert any object into the PDB's slits and openings. Do not put beverages on or around the PDB.
- Do not use any cleaning liquid or cleaning spray to clean the PDB. Before cleaning, please make sure that the input power cables have been unplugged.

- All maintenance services must be performed by qualified service personnel.
- Forbid opening or removing the cover of the PDB by yourself to avoid high voltage electric shock.
- You must contact qualified service personnel if either of the following events occurs:
 1. Liquid is poured or splashed on the PDB.
 2. The PDB does not run normally after the instructions in this **User Manual** are carefully observed.

2.2 Standard Compliance

- IEC/EN 62040-1

2.3 Storage

- **Prior to installation**

If the PDB needs to be stored prior to installation, it should be placed in a dry and well-ventilated area. The allowable storage temperature is between -15°C (5°F) and +55°C (131°F) and the allowable relative humidity (non-condensing) is between 5% and 95%.

- **After usage**

Remove all equipment from the PDB and store the PDB in a dry and well-ventilated area at a temperature between -15°C (5°F) and +55°C (131°F) and at a relative humidity (non-condensing) between 5% and 95%.

Chapter 3 : Package List

The package contains the following items shown in **Figure 3-1**. Please check if any item is missing. If there is anything missing, please contact the dealer immediately.

Model: PDB-RT-10/15/20K

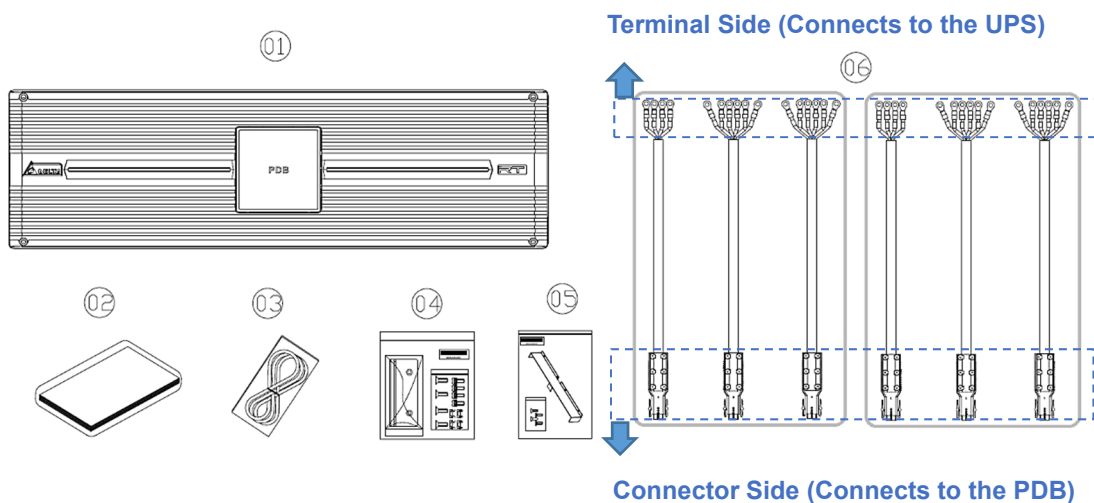

(Figure 3-1: PDB Package List)

No.	Item	Quantity
1	PDB	1 PC
2	User Manual	1 PC
3	PDB Communication Cable	1 PC
4	Ear Bracket Kit	1 Set
5	Protection Cover with Screws*1	1 Set
6	Power Cables*2	2 Sets*3



NOTE:

1. *¹ The protection cover should be installed on the PDB to protect the power cables as shown in **Figure 6-16**.
2. *² This accessory item is only for the UPS model without the power cables already being installed on the UPS before shipment. Note that the power cable connection should be performed by qualified service personal. For details, please refer to **6.2 Connection with the UPS Model without the Power Cables Already Installed before Shipment**.
3. *³ For each set, there are 3 power cables: main AC input power cable (4 pins), bypass input power cable (6 pins) and UPS output power cable (6 pins). Each power cable's connector is marked with the colors corresponding to the port on the PDB's rear panel (see **Figure 4-4**) so that you can identify the power cables easily.
4. If there is any damage or anything missing, please immediately contact the dealer from whom you purchased the unit.
5. If the PDB needs to be returned, carefully repack the PDB and all of the accessories with the original packing materials.

Chapter 4 : Appearance, Dimensions & Panels



NOTE:

1. There are input, bypass, and output breakers as well as a manual bypass switch behind the PDB's front cover. For details, see **Figure 4-3** and its following table.

See **Figure 4-1** for the PDB's appearance and dimensions.

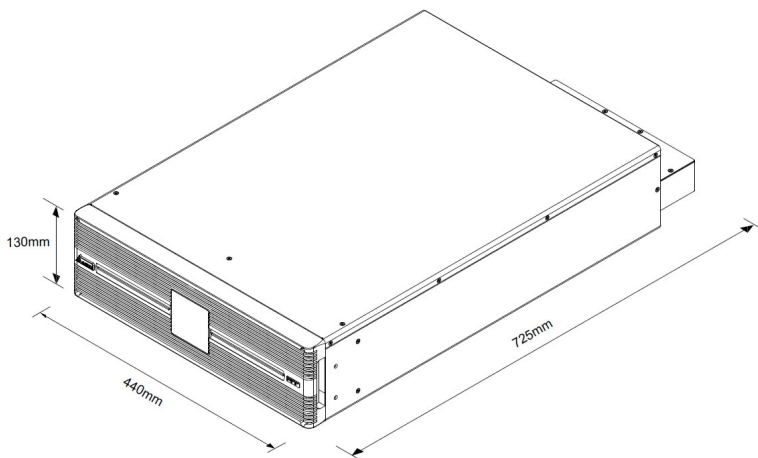

(Figure 4-1: PDB's Appearance & Dimensions)

4.1 Inner Front Panel

Remove the PDB's front cover (see **Figure 4-2**) and you will see the inner front panel with the input, bypass, and output breakers as well as a manual bypass switch. For details, see **Figure 4-3** and the table below.

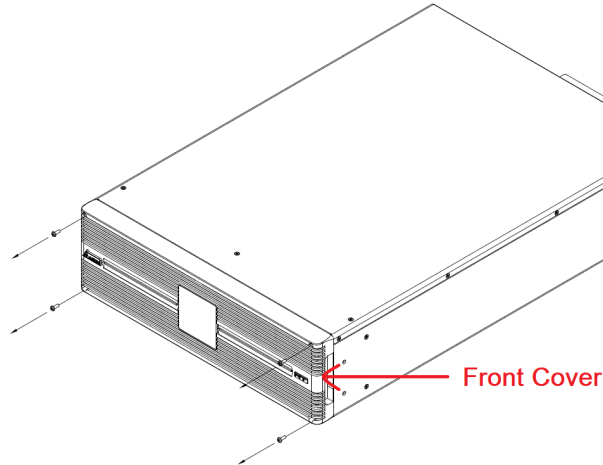

(Figure 4-2: PDB's Front Cover)

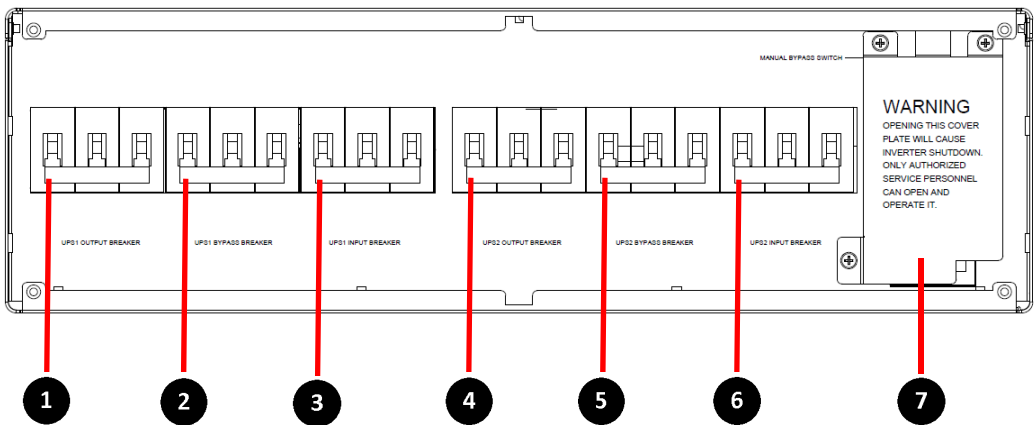



(Figure 4-3: PDB's Inner Front Panel)



NOTE:

1. For the breakers (❶) ~ (❷), when in the **upward** position, it means the circuit is closed and the power is turned **ON**; when in the **downward** position, it means the circuit is open and the power is turned **OFF**.

No.	Item	Function
①	UPS1 OUTPUT BREAKER	Opens or closes the UPS1 output circuit.
②	UPS1 BYPASS BREAKER	Opens or closes the UPS1 bypass input circuit.
③	UPS1 INPUT BREAKER	Opens or closes the UPS1 main AC input circuit.
④	UPS2 OUTPUT BREAKER	Opens or closes the UPS2 output circuit.
⑤	UPS2 BYPASS BREAKER	Opens or closes the UPS2 bypass input circuit.
⑥	UPS2 INPUT BREAKER	Opens or closes the UPS2 main AC input circuit.
⑦	MANUAL BYPASS SWITCH (Covered*1)	<p>You can switch ON the manual bypass switch to transfer the UPS to manual bypass mode so that the UPS maintenance can be performed without power interruption. For details, please refer to Chapter 8: Maintenance Bypass.</p> <p> NOTE: *1 After you unscrew the 3 screws shown in Figure 8-1 and remove the warning cover plate, you will see the manual bypass switch. Meanwhile, the PDB's detector will be activated automatically, and it will send a message to make the UPS transfer to bypass mode.</p> <p> WARNING: Opening the warning cover plate will cause inverter shutdown. Only authorized service personnel can open and operate it.</p>

4.2 Rear Panel

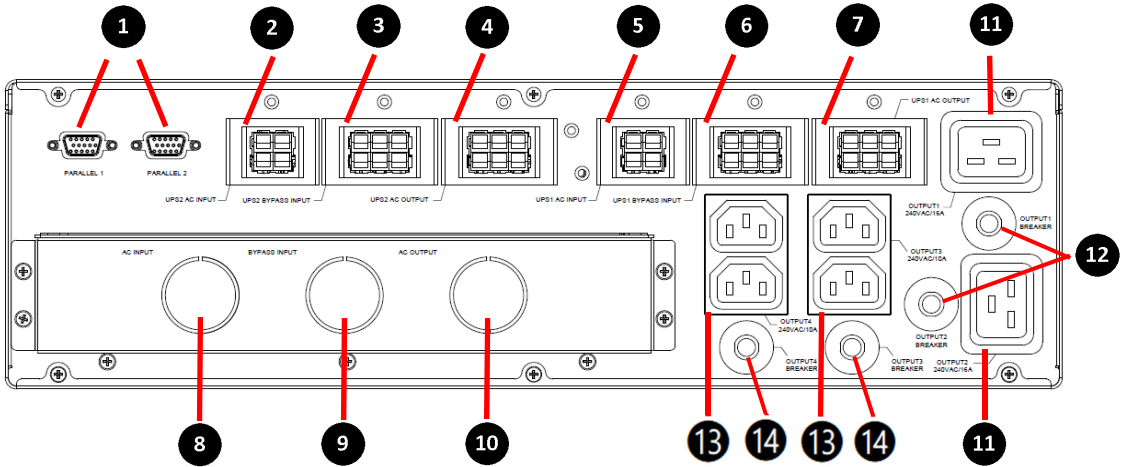

(Figure 4-4: PDB's Rear Panel)

No.	Item	Function
①	PARALLEL 1/ PARALLEL 2 Port	Connects to the UPS's parallel ports to facilitate parallel communication.
②	UPS2 AC INPUT Port*1	Connects to the main input power cable installed on the UPS2.
③	UPS2 BYPASS INPUT Port*1	Connect to the bypass input power cable installed on the UPS2.
④	UPS2 AC OUTPUT Port*1	Connect to the output power cable installed on the UPS2.
⑤	UPS1 AC INPUT Port*1	Connects to the main input power cable installed on the UPS1.
⑥	UPS1 BYPASS INPUT Port*1	Connect to the bypass input power cable installed on the UPS1.
⑦	UPS1 AC OUTPUT Port*1	Connect to the output power cable installed on the UPS1.
⑧	AC INPUT Terminals*2 (behind the knockout cover)	Include mL1 / mL2 / mL3 / N*3 terminals which connect to the main AC source. For details, please refer to Chapter 6: Connection .

9	BYPASS INPUT Terminals* ² (behind the knockout cover)	Include bL1 / bL2 / bL3 / N* ³ terminals which connect to the bypass source. For details, please refer to Chapter 6: Connection .
10	AC OUTPUT Terminals* ² (behind the knockout cover)	Include L1 / L2 / L3 / N terminals which connect to the critical loads. For details, please refer to Chapter 6: Connection .
11	OUTPUT 1/ OUTPUT 2 240VAC/ 15A Outlet	AC single phase outlets, including two IEC-320 C19 outlets for your power distribution needs.
12	OUTPUT 1/ OUTPUT 2 BREAKER	OUTPUT 1/ OUTPUT 2's circuit breaker.
13	OUTPUT 3/ OUTPUT 4 240VAC/ 10A Outlet	AC single phase outlets, including four IEC-320 C13 outlets for your power distribution needs.
14	OUTPUT 3/ OUTPUT 4 BREAKER	OUTPUT 3/ OUTPUT 4's circuit breaker (two outlets per breaker).



NOTE:

1. *¹ There are two sets of ports on the PDB's rear panel for power cable connection: (2) (3) (4) and (5) (6) (7). Each set of the three ports are originally covered with a plate before shipment. Before connecting the power cables, please remove the plate(s). For details about the power cable connection, please refer to **Chapter 6: Connection**. Note that the plate(s) should be reinstalled after you disconnect the power cables from the PDB.
2. *² To see all the PDB wiring terminals (8) (9) (10), please remove the upper cover at the rear of the PDB. For the terminal cover location, see **Figure 6-6**. For the PDB's wiring terminals, see **Figure 6-7**. To perform the PDB wiring, you have to remove the three knockout covers (see **Figure 6-6**) and install the cable glands (user-supplied). For details, please refer to **Chapter 6: Connection**.
3. *³ For dual-source input configurations, the main AC source and the bypass source must use the same neutral (N). For details, please refer to **Chapter 6: Connection**.

Chapter 5 : Installation

Please follow the steps below to conduct rack mounting.

Step 1

Fix the ear brackets (provided in the package) onto the PDB and verify that all screws have been fastened properly. See **Figure 5-1**.

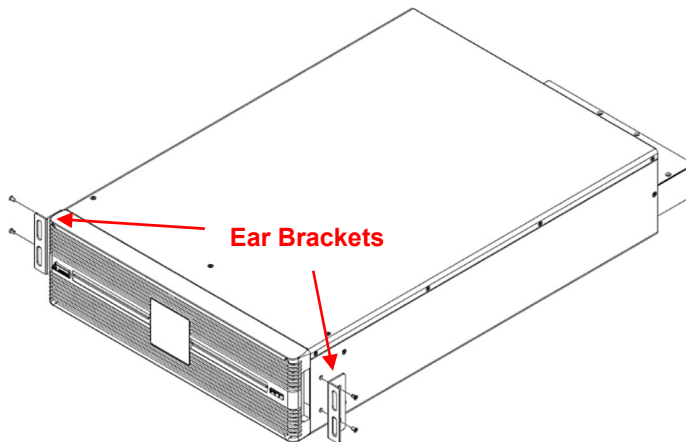

(Figure 5-1: Fix the Ear Brackets onto the PDB)

Step 2

Adjust the length of the rails to fit in a standard 482.6mm (19") server rack and then tighten the nuts (the rails and nuts are provided in the optional rail kit). See **Figure 5-2**.

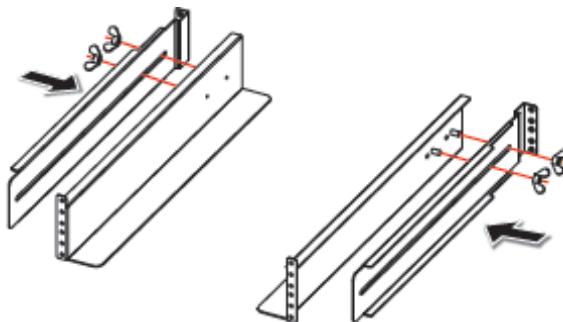

(Figure 5-2: Adjust the Rails & Tighten the Nuts)

Step 3

Use the eight screws and eight washers to fix the rails onto your rack (the screws and washers are provided in the optional rail kit). See **Figure 5-3**.

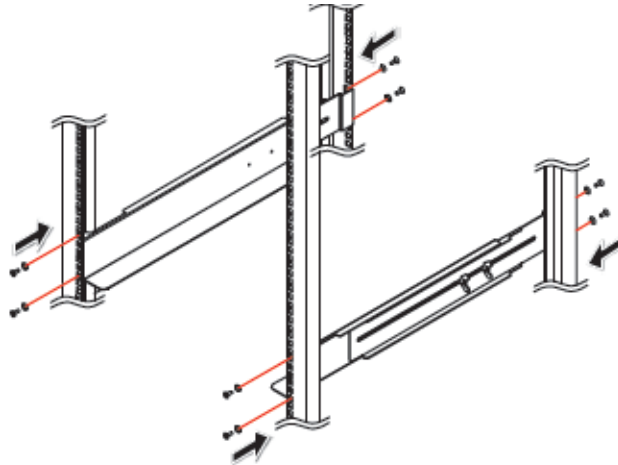

(Figure 5-3: Fix the Rails onto Your Rack)

Step 4

Carefully insert the PDB into your rack and tighten the four screws provided in the ear bracket kit. See **Figure 5-4**. Please note that there will be extra four nuts left after installation. These four nuts are spare parts used when the screw holes of your rack are unthreaded.

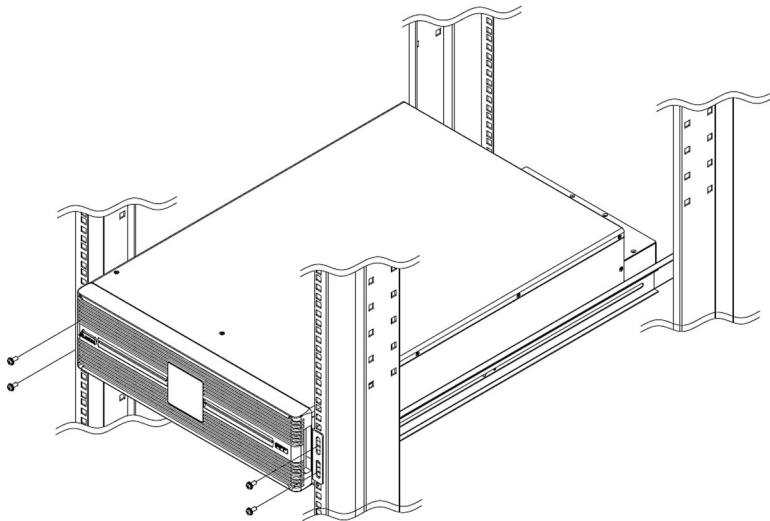

(Figure 5-4: Insert the PDB into Your Rack)



NOTE:

When the PDB is connected to UPS(s), the PDB should be installed above or under the UPS(s) depending on the installation environment. **Figure 6-14** and **Figure 6-15** are examples of the PDB being installed above the UPS(s).

Step 5

Remove the four screws on the PDB's front cover and leave it fixed only by the two clips. The four screws are to ensure that the PDB's front cover will not detach during transportation; however, they must be removed after installation so that users can easily open the PDB's front cover by hands to operate the breakers anytime (see **Figure 4-3**) in case of emergencies.

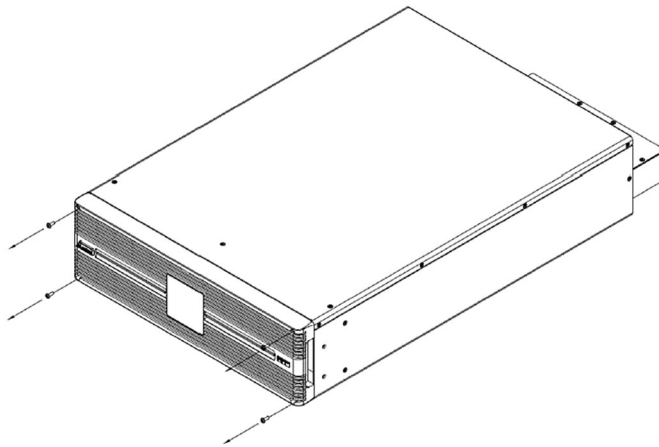

(Figure 5-5: Remove the Four Screws on the PDB's Front Cover)

Chapter 6 : Connection

The PDB provides AC input power to the UPS(s) and connects the output of the UPS(s) to the critical loads. First, make sure the power cables have been connected to the UPS(s). After that, connect the PDB with the AC source(s) and critical loads (for wiring only, do not supply the power at the moment) and then connect the power cables (with the other end already connected to the UPS's wiring terminals) to the PDB.



NOTE :

1. You can choose either single-source input or dual-source input and either single-phase output or three-phase output by adopting different wiring configurations. For details, please refer to sections **6.3.1 ~ 6.3.4**.
2. Regarding connection between the UPS and the Delta's optional battery pack, refer to the **User Manual** and of the UPS and the Delta's optional battery pack.

6.1 Pre-connection Warnings

The cables to be connected to the PDB's wiring terminals (⑧ ~ ⑩ in **Figure 4-4**) include main input, bypass input and output cables. When choosing the cables, please follow the local wiring regulations and consider environmental conditions.

● Cable Selection

Table 6-1 shows the nominal current of the PDB with different phase configurations (three-phase or single-phase). **Table 6-2** lists the recommended minimum cross-sectional areas of the cables. Select the appropriate cables according to **Table 6-1** and **Table 6-2**.

● External Protection Device

You must install a circuit breaker (or other protection device) between the main AC source and the PDB. If you adopt dual-input configurations, you must also install a circuit breaker (or other protection device) between the bypass source and the PDB. For the capacity of the circuit breakers, please refer to **Table 6-3**.

This section provides general guidance for qualified installation engineers. A qualified installation engineer should be aware of local wiring regulations and other relevant knowledge.

Table 6-1: PDB Nominal Current

Wiring Configuration (Input Phase: Bypass Phase: Output Phase)	Nominal Input Phase Current (A)			Nominal Output Phase Current* ¹ (A)		
	Rated Input Voltage			Rated Output Voltage		
	220/380V	230/400V	240/415V	220/380V	230/400V	240/415V
(3:3:3)	Main: 63A (3P) Bypass: 61.2A (3P)	Main: 63A (3P) Bypass: 58.6A (3P)	Main: 63A (3P) Bypass: 56.2A (3P)	60.6A (3P)	58A (3P)	55.6A (3P)
(3:1:1)	Main: 41.2A (3P) Bypass: 91.8A (1P)	Main: 39.4A (3P) Bypass: 87.9A (1P)	Main: 37.3A (3P) Bypass: 84.3A (1P)	90.9A (1P)	87A (1P)	83.4A (1P)



NOTE:

1. A maximum voltage drop allowable for each cable is 4Vac.
2. To avoid electromagnetic interference, do not loop the cable.
3. *¹ The use of non-linear loads will influence your selection of the output and bypass neutral cables. The current of the neutral cables may exceed the rated phase current and can be up to 1.732 times the rated phase current. In such a condition, you have to use cables with larger diameters. Please contact service personnel for more information.

Table 6-2: Recommended Minimum Cable Size (Environment Temperature: 25°C (77°F))

Wiring Configuration (Input P: Bypass P: Output P)	Input		Output		Bypass		Neutral Line		Ground	
	mm ²	AWG	mm ²	AWG	mm ²	AWG	mm ²	AWG	mm ²	AWG
(3:3:3)	10	6	10	6	10	6	10	6	10	6
(3:1:1)	10	6	10 × 3PCS	6 × 3PCS	10 × 3PCS	6 × 3PCS	10 × 3PCS	6 × 3PCS	35	1



NOTE:

Only qualified personnel can perform installation, wiring, operation and maintenance.
Prior to supplying any power to the PDB, make sure the PDB has been suitably grounded.

Table 6-3: Protection Device Capacity

Wiring Configuration (Input P: Bypass P: Output P)	Recommended Input Breaker Capacity for RT-15K3P	Recommended Input Breaker Capacity for RT-20K3P
(3:3:3)	<u>With One UPS</u> 50A/ Type D (main) 50A/ Type D (bypass)	<u>With One UPS</u> 63A/ Type D (main) 63A/ Type D (bypass)
	<u>With Two UPS</u> 100A/ Type D (main) 100A/ Type D (bypass)	<u>With Two UPS</u> 125A/ Type D (main) 125A/ Type D (bypass)
(3:1:1)*¹	<u>With One UPS</u> 50A/ Type D (main) 100A/ Type D (bypass)	<u>With One UPS</u> 63A/ Type D (main) 125A/ Type D (bypass)



NOTE:

1. For dual-source input configurations, the main AC source and the bypass source must use the same neutral (N).
2. For the three-phase system, you must use the four-pole protection device. For the single-phase system, you must use the two-pole protection device.
3. *¹ Single-phase output is not applicable to the PDB connected to parallel UPSs.

6.2. Connection with the UPS Model without the Power Cables Already Installed before Shipment

The PDB should be connected with the UPS(s) by the power cables which have been installed on the UPS(s). If the UPS model you purchased is without the power cables and cable glands already installed on the UPS before shipment, the main input, bypass input and output power cables provided in the PDB's package will need to be connected to the UPS's wiring terminals (including the AC input terminals, bypass input terminals, UPS output terminals and grounding terminal (\oplus)). For details about the UPS's wiring terminals, please refer to the UPS's *User Manual*.

In this case, please follow the steps below to perform the power cable connection between the UPS and the PDB. Note that the connection should be performed by qualified service personnel.

Step 1

Remove the upper cover at the rear of the UPS and the three knockout covers from UPS's rear panel. See **Figure 6-1**. After removing them, you can see the UPS's wiring terminals from top.



NOTE:

1. After completing the power cable connection to the UPS's wiring terminals, you should reinstall the upper cover at the rear of the UPS.
2. The knockout covers cannot be reinstalled once removed.

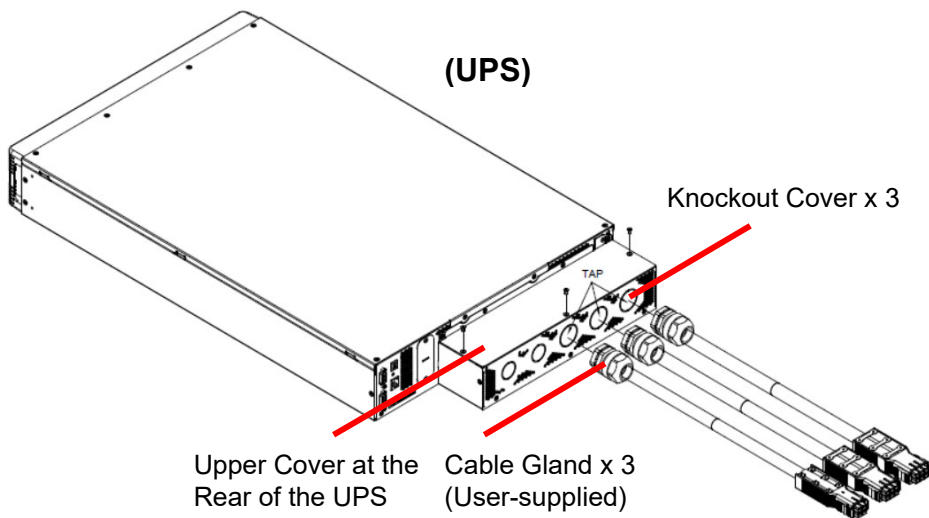

(Figure 6-1: Location of the Upper Cover at the Rear of the UPS and the Three Knockout Covers on the UPS's Rear Panel)

Step 2

Please follow sequence (1) ~ (3) below to connect the provided power cables to the UPS's wiring terminals (including the AC input terminals, the bypass input terminals, the UPS output terminals and the grounding terminal (⊕)). You should use three cable glands (user-supplied) to firmly fix the power cables on the UPS (see **Figure 6-1**).



NOTE:

For connection to the UPS's grounding terminal (⊕), please refer to the UPS's **User Manual**. The grounding method of the UPS is the same as which of the PDB. You can also see **Figure 6-8** for reference.

(1) Fix the 4 pins of the main input power cable to the UPS's AC input terminals (mL1, mL2, mL3 and N). Note that the 4 pins should be connected to the correct position as shown in **Figure 6-2**.

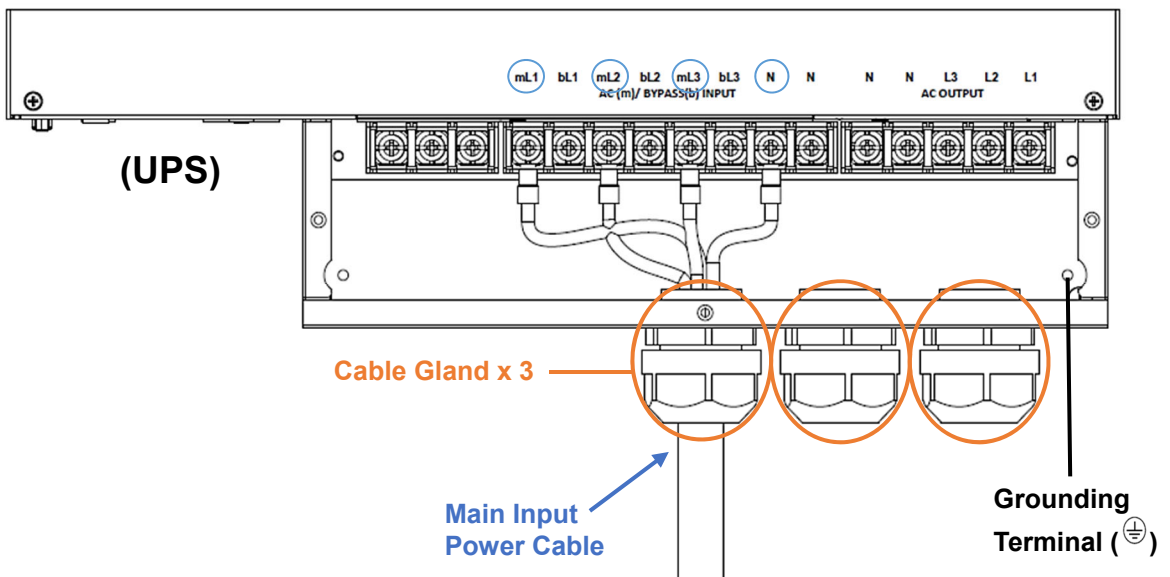

(Figure 6-2: Connect the Main Input Power Cable to the UPS's AC Input Terminals)

(2) Fix the 6 pins of the bypass input power cable to the UPS's bypass input terminals (bL1, bL2, bL3 and N) and the grounding terminal (\oplus). Note that the 6 pins should be connected to the correct position as shown in **Figure 6-3**.

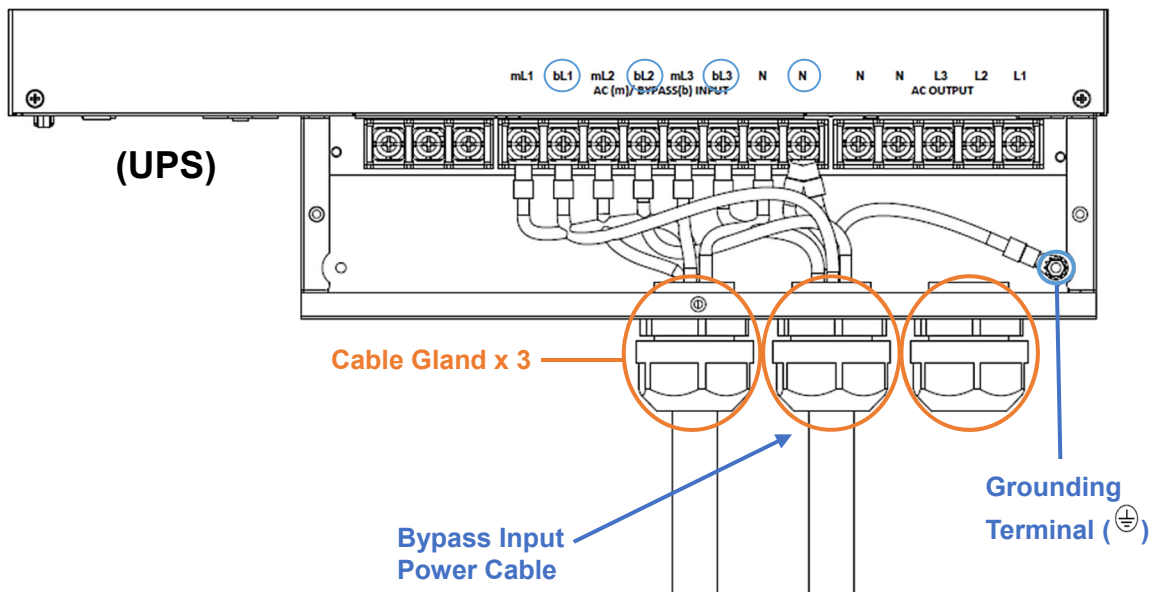

(Figure 6-3: Connect the Bypass Input Power Cable to the UPS's Bypass Input Terminals and Grounding Terminal (\oplus))

(3) Fix the 6 pins of the output power cable to the UPS's output terminals (L1, L2, L3, N and N) and the grounding terminal (\oplus). Note that the 6 pins should be connected to the correct position as shown in **Figure 6-4**.

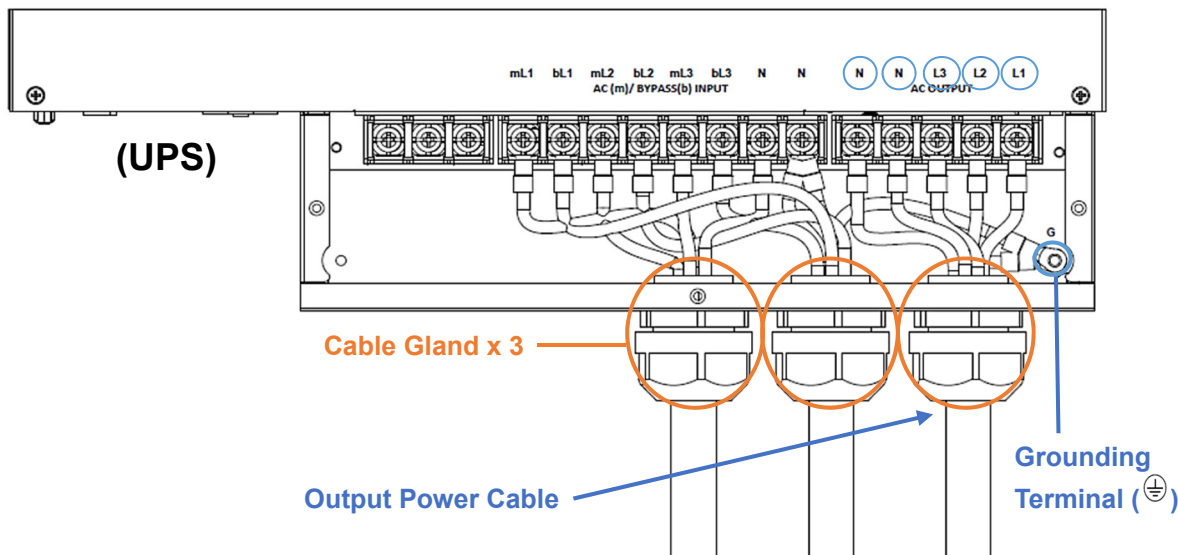

(Figure 6-4: Connect the Output Power Cable to the UPS's Output Terminals and Grounding Terminal(\oplus))

Step 3

Reinstall the upper cover at the rear of the UPS. See **Figure 6-5**.

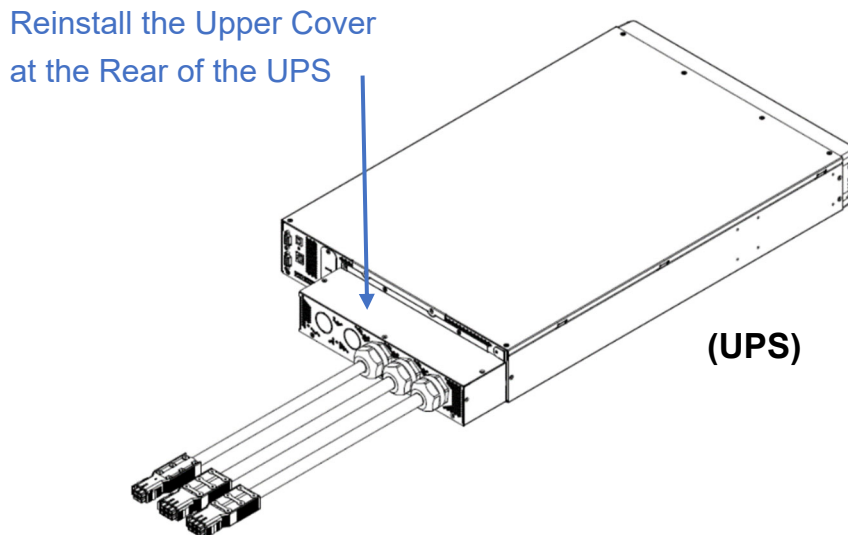

(Figure 6-5: Reinstall the Upper Cover at the Rear of the UPS)

6.3 PDB Wiring

The PDB wiring cables need to be connected to the PDB's AC input, bypass input, AC output and grounding terminals, which you can see after removing the upper cover at the rear of the PDB. See **Figure 6-6** and **Figure 6-7**. You should remove the three knockout covers and use three cable glands (user-supplied) to firmly fix the power cables on the PDB.



NOTE:

1. After completing the PDB wiring, you should reinstall the upper cover at the rear of the PDB.
2. The knockout cover cannot be reinstalled once removed.

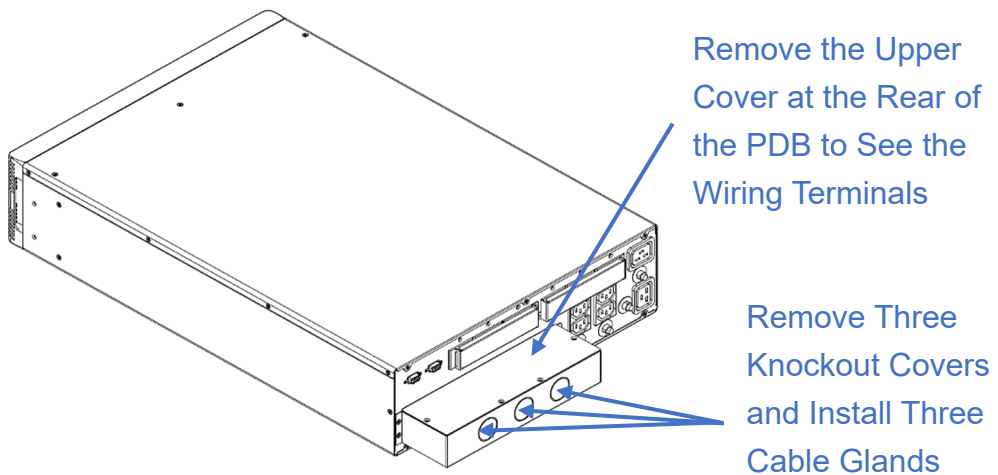

(Figure 6-6: Location of the PDB's Upper Cover at Rear and the Three Knockout Covers on the PDB's Rear Panel)



NOTE:

The cable gland installation of the PDB is the same as which of the UPS. See **Figure 6-1** for reference.

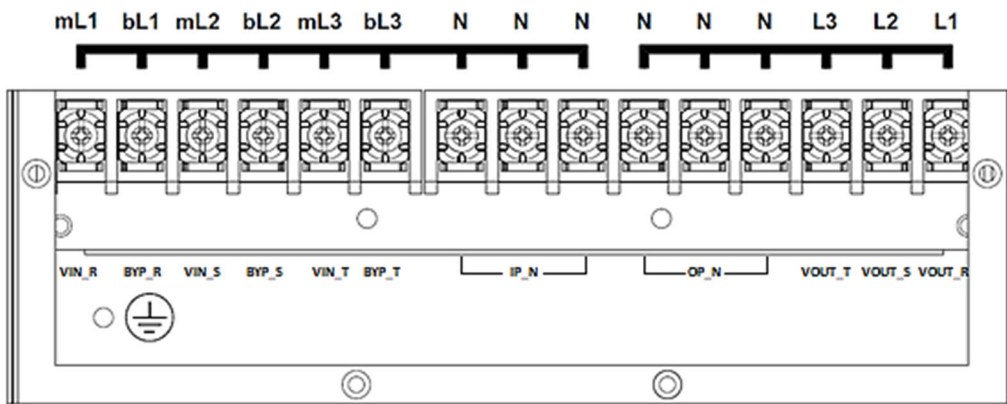

(Figure 6-7: PDB's Wiring Terminals)

For details about the PDB's wiring terminals, refer to the table below.

No.	Item	Description	Function
1	AC Input Terminals	Include mL1 (VIN_R), mL2 (VIN_S), mL3 (VIN_T), and N (IP_N)*1 terminals.	Connect to the main AC source.
2	Bypass Input Terminals	Include bL1 (BYP_R), bL2 (BYP_S), bL3 (BYP_T), and N (IP_N)*1 terminals.	Connect to the bypass source*2.
3	Ac Output Terminals	Include L1 (VOUT_R), L2 (VOUT_S), L3 (VOUT_T), and N (OP_N) terminals.	Connect to the critical loads.
4		Includes one grounding terminal.	<ol style="list-style-type: none"> 1. For PDB's earthing protection: connects to the main AC source and bypass source*2 grounding. 2. For bonding: connects to the load grounding. 3. When performing the grounding, please refer to the steps below and see Figure 6-8.



NOTE:

*1 For dual-source input configurations, the main AC source and the bypass source must use the same neutral (N).

*2 For the UPS with dual-source input configurations only.

- **PDB Grounding Terminal (\oplus) Locking Method**

To ensure the PDB's earthing protection, when conducting connection to the PDB's grounding terminal (\oplus), please follow the steps below and sequence ❶ ~ ❸*¹ shown in **Figure 6-8**.



NOTE:

*¹ The components ❶ ~ ❸ shown in **Figure 6-8** are not provided in the PDB's package. Users should prepare the protective earthing terminal, protective bonding terminal, lock washers and nuts.

Step 1 (for earthing)

Fix the protective earthing terminal (❶) with a lock washer first (❷) and then with a nut (❸). The earthing terminal connects to the main AC source (and bypass source) grounding.

Step 2 (for bonding)

Fix the protective bonding terminal (❹) with a lock washer first (❺) and then with a nut (❻). The bonding terminal connects to the load grounding.

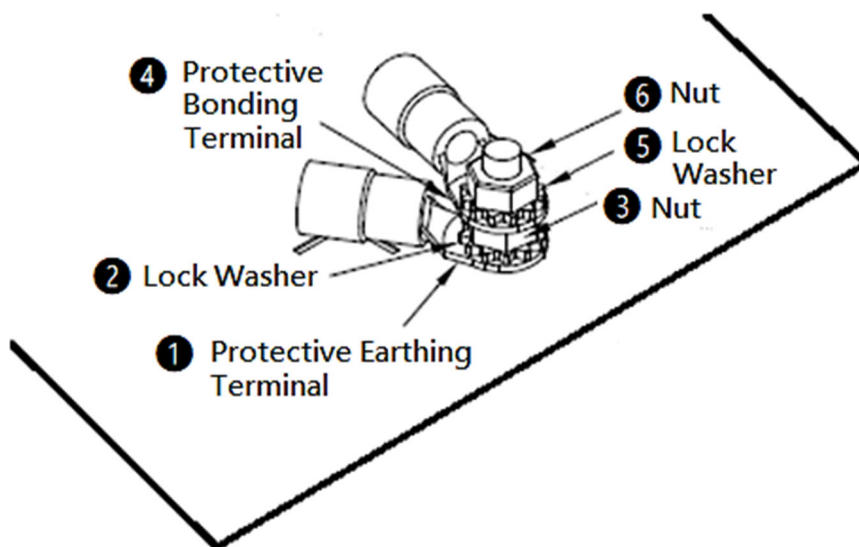

(Figure 6-8: PDB's Grounding Terminal (\oplus)_ Earthing Terminal & Bonding Terminal Locking Method)

The PDB input can be set as single-source or dual-source input and the PDB output can be set as three-phase or single-phase output, which depends on the way you install the bus bars (provided in the package) and the output phase setting on the LCD. There are four kinds of configurations for your choice. See sections **6.3.1 ~ 6.3.4** below for the four kinds of wiring methods (the **PDB's wiring terminals** are marked in **block font**).

6.3.1 Single-Phase Output & Single-Source Input



NOTE:

Single-phase output is not applicable to the PDB connected to parallel UPSs.

1. Install the bus bars according to **Figure 6-9**.
2. Connect the main AC source (L1/ L2/ L3/ N): connect L1 to **mL1**, **bL1**, **bL2**, or **bL3**; L2 to **mL2**; L3 to **mL3**; N to the input **N** terminal(s).
3. Connect the loads (L/ N): connect the loads' L to **L1**, **L2**, or **L3** and the loads' N to the output **N** terminal(s).

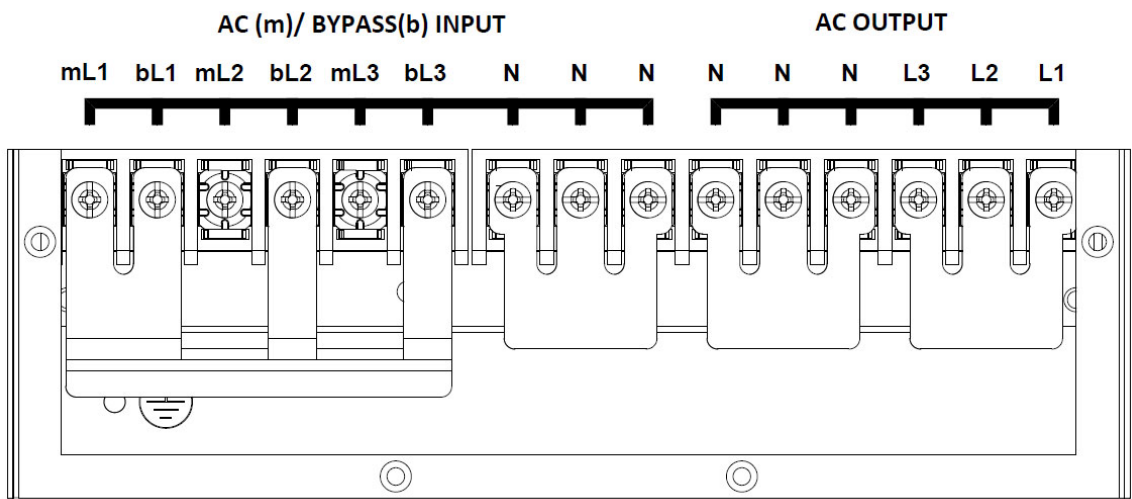

(Figure 6-9: PDB's Bus Bar Installation for Single-Phase Output & Single-Source Input Configurations)

6.3.2 Single-Phase Output & Dual-Source Input



NOTE:

Single-phase output is not applicable to the PDB connected to parallel UPSs.

1. Install the bus bars according to **Figure 6-10**.
2. Connect the main AC source (L1/ L2/ L3/ N): connect L1 to **mL1**; L2 to **mL2**; L3 to **mL3**; N*¹ to the input **N** terminal(s).
3. Connect the bypass source (L/ N): connect L to **bL1**, **bL2**, or **bL3**; N*¹ to the input **N** terminal(s).



NOTE:

*¹ For dual-source input configurations, the main AC source and bypass source must use the same neutral (N).

4. Connect the loads (L/ N): connect the loads' L to **L1**, **L2**, or **L3** and the loads' N to the output **N** terminal(s).

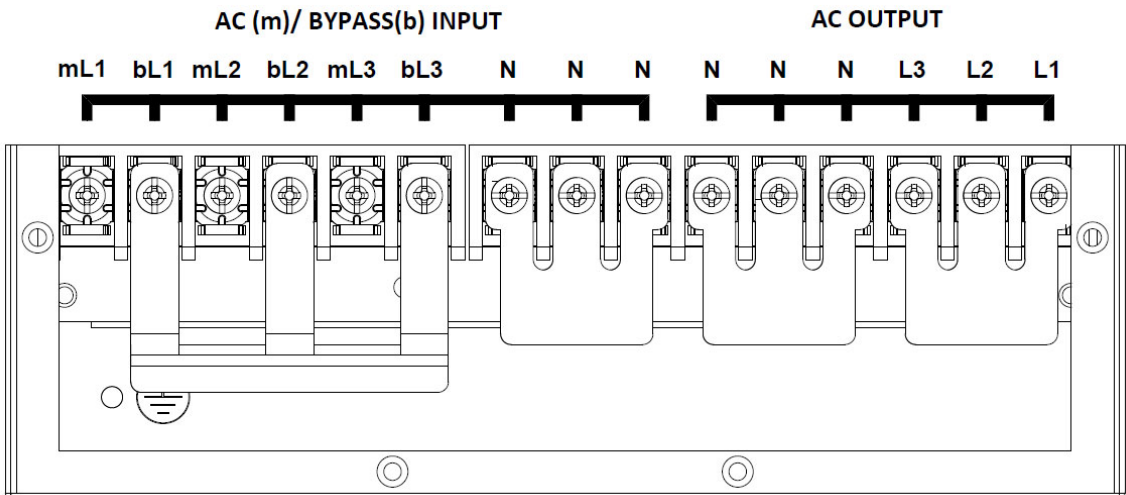

(Figure 6-10: PDB's Bus Bar Installation for Single-Phase Output & Dual-Source Input Configurations)

6.3.3 Three-Phase Output & Single-Source Input

1. Install the bus bars according to **Figure 6-11**.
2. Connect the main AC source (L1/ L2/ L3/ N): connect L1 to **mL1** or **bL1**; L2 to **mL2** or **bL2**; L3 to **mL3** or **bL3**; and N to the input **N** terminal(s).
3. Connect the loads (L1/ L2/ L3/ N): connect the loads' L1/ L2/ L3 to **L1/ L2/ L3** respectively and the loads' N to the output **N** terminal(s).

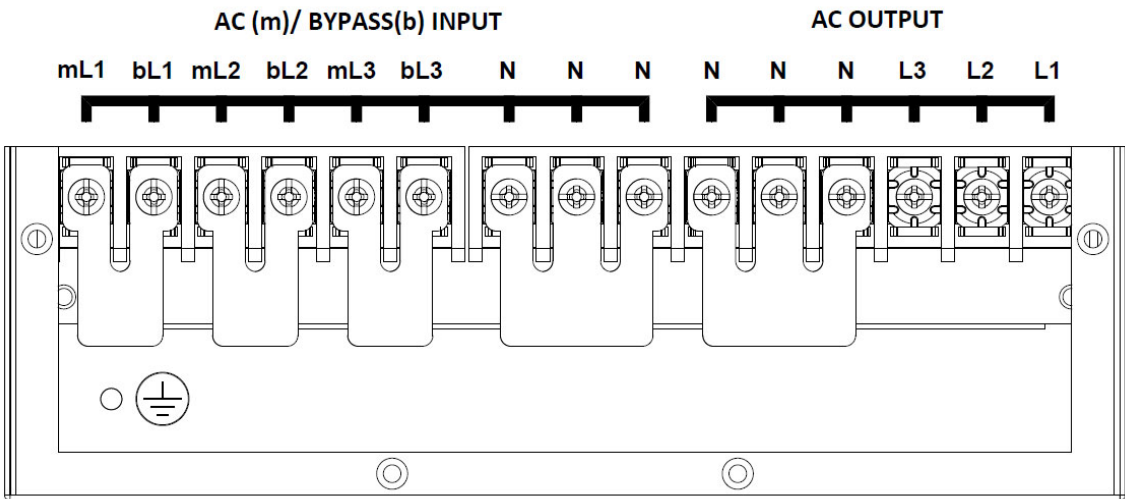

(Figure 6-11: PDB's Bus Bar Installation for Three-Phase Output & Single-Source Input Configurations)

6.3.4 Three-Phase Output & Dual-Source Input

1. Install the bus bars according to **Figure 6-12**.
2. Connect the main AC source (L1/ L2/ L3/ N): connect L1 to **mL1**; L2 to **mL2**; L3 to **mL3**; and N*¹ to the input **N** terminal(s).
3. Connect the bypass source (L1/ L2/ L3/ N): connect L1 to **bL1**; L2 to **bL2**; and L3 to **bL3**; N*¹ to the input **N** terminal(s).



NOTE:

*¹ For dual-source input configurations, the main AC source and bypass source must use the same neutral (N).

4. Connect the loads (L1/ L2/ L3/ N): connect the loads' L1/ L2/ L3 to **L1/ L2/ L3** respectively and the loads' N to the output **N** terminal(s).

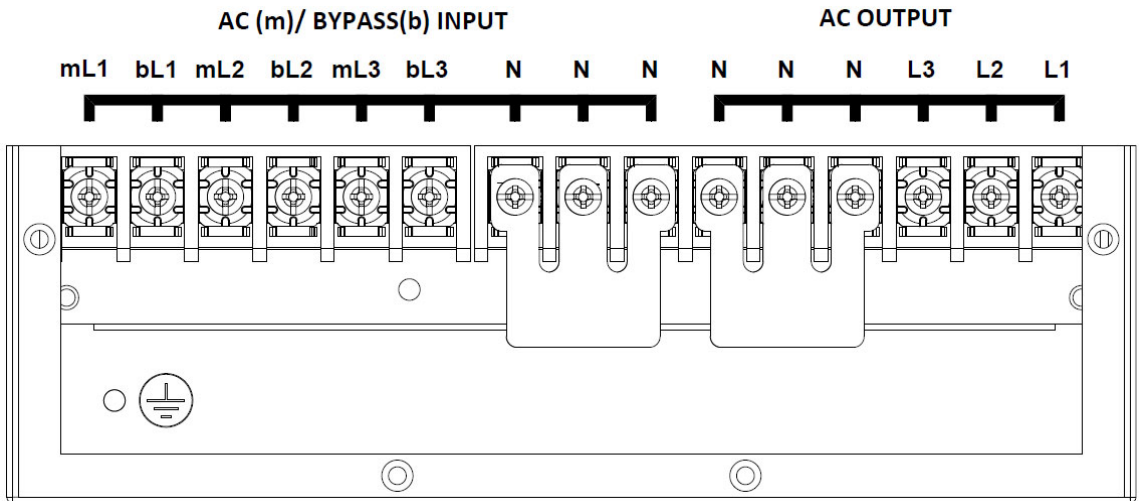

(Figure 6-12: PDB's Bus Bar Installation for Three-Phase Output & Dual-Source Input Configurations)

6.4 PDB and UPS Connection

The PDB can be connected to one single UPS or two parallel UPSs.



NOTE:

For the UPS and PDB connection, the UPS must be installed with the power cables and cable glands as shown in **Figure 6-13** before it is shipped. However, this depends on different UPS model requirements as the PDB is an optional accessory. If the UPS model you purchased is not installed with the power cables and cable glands, please refer to **6.2. Connection with the UPS Model without the Power Cables Already Installed before Shipment** to complete the power cable connection to the UPS.

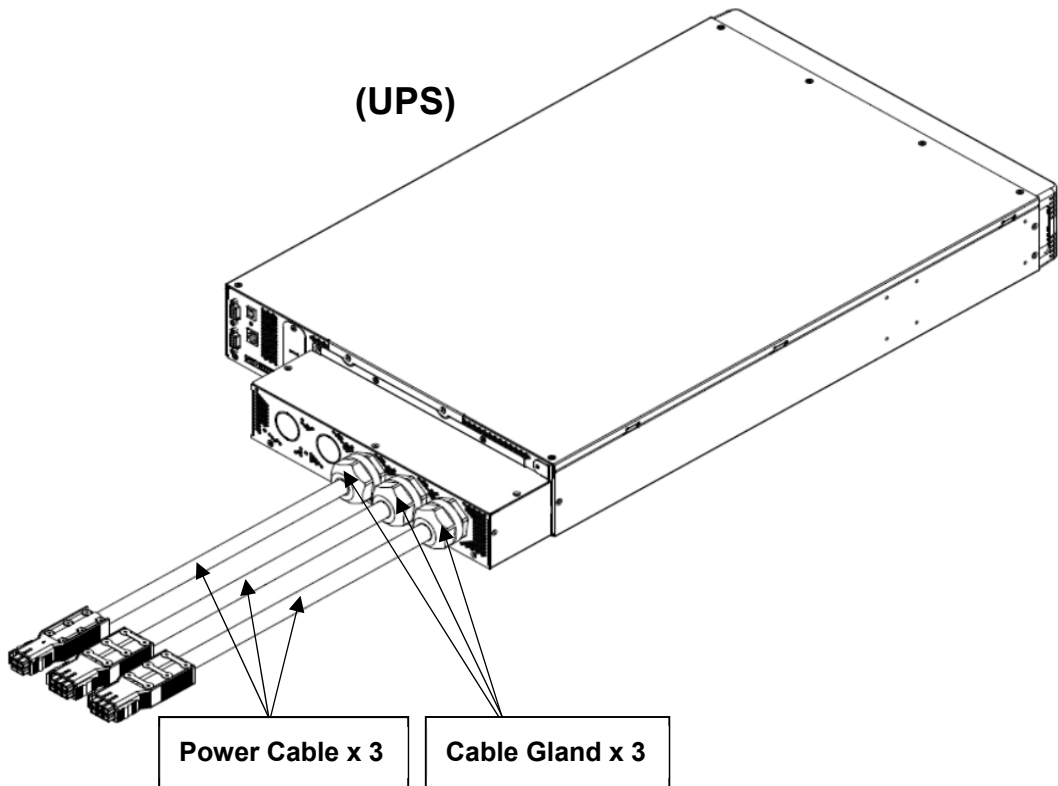

(Figure 6-13: UPS Model with the Power Cables and Cable Glands Already Installed before Shipment)

6.4.1 PDB with Single UPS

Follow ❶ ~ ❸ in *Figure 6-14* to insert the three power cables (with the other end already connected to the UPS's wiring terminals) into the corresponding ports on the PDB's rear panel (see *Figure 4-4*).

Use the provided PDB communication cable to connect the UPS's parallel port with the PDB's parallel port (see *Figure 4-4*). Refer to ❹ in *Figure 6-14*.

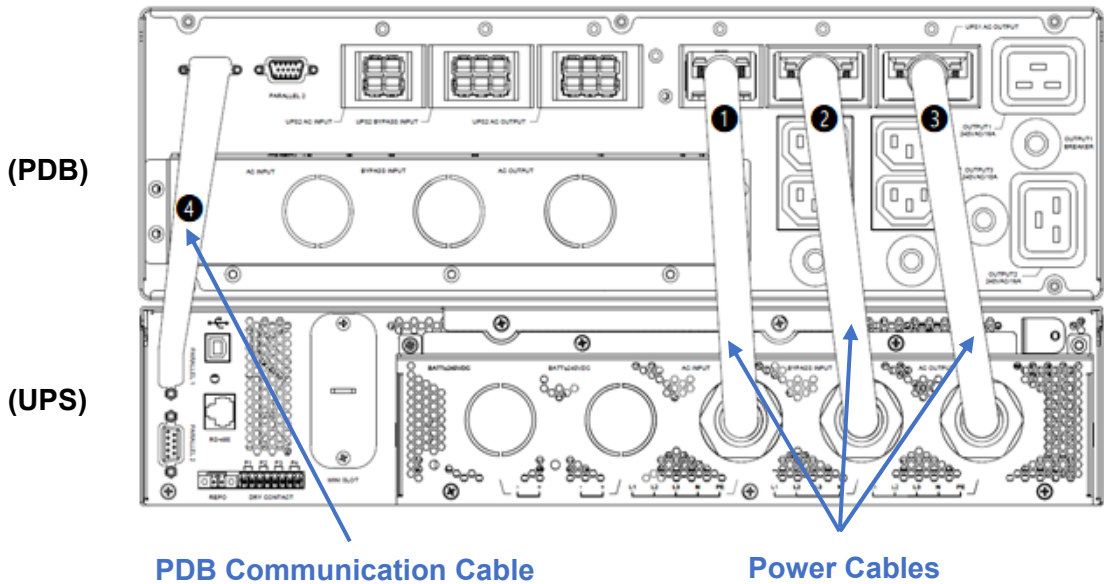

(Figure 6-14: Connect the PDB with Single UPS)

6.4.2 PDB with Parallel UPSs

Follow ① ~ ③ in **Figure 6-15** to insert the three power cables (with the other end already connected to the UPS1's wiring terminals) into the corresponding ports on the PDB's rear panel (see **Figure 4-4**).

Follow ④ ~ ⑥ in **Figure 6-15** to insert the three power cables (with the other end already connected to the UPS2's wiring terminals) into the corresponding ports on the PDB's rear panel (see **Figure 4-4**).

Use the provided PDB communication cable and the parallel cable provided in each UPS's package to connect the UPSs' parallel ports and the PDB's parallel ports (see **Figure 4-4**). Refer to ⑦ & ⑧ in **Figure 6-15**.

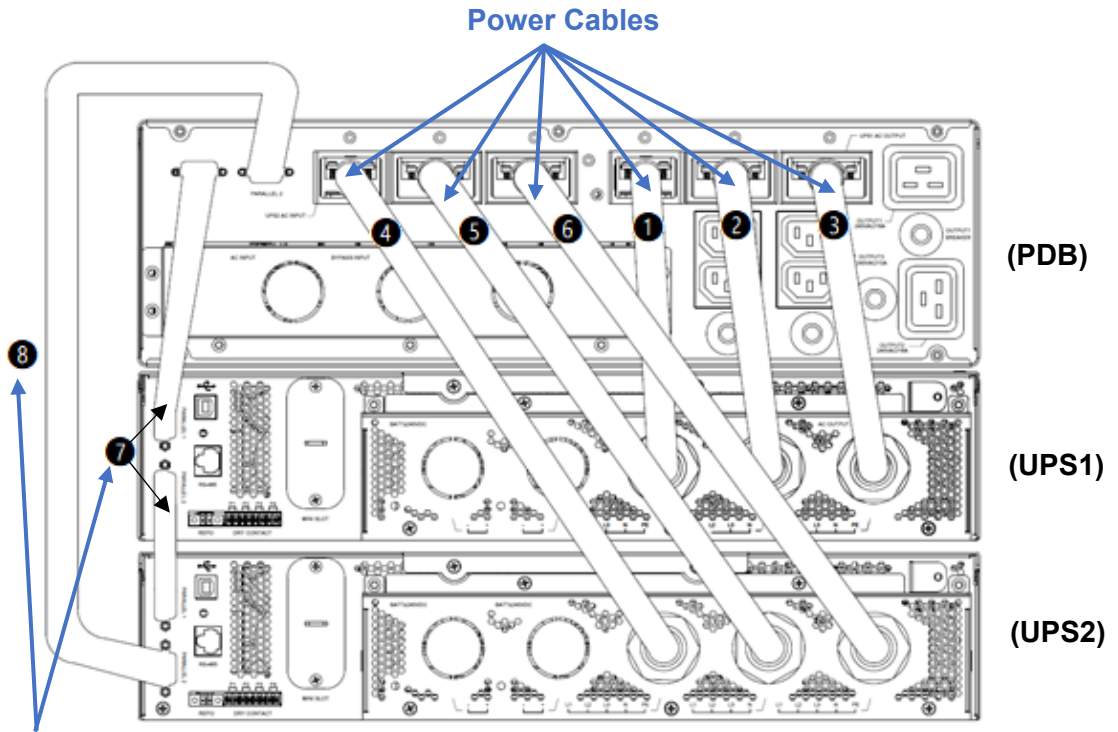

PDB Communication Cable (8) & UPS Parallel Cables (7)

(Figure 6-15: Connect the PDB with Parallel UPSs)

6.4.3 Install the Protection Cover above the Power Cables

Install the provided protection cover onto the PDB to protect the power cables. See **Figure 6-16**.

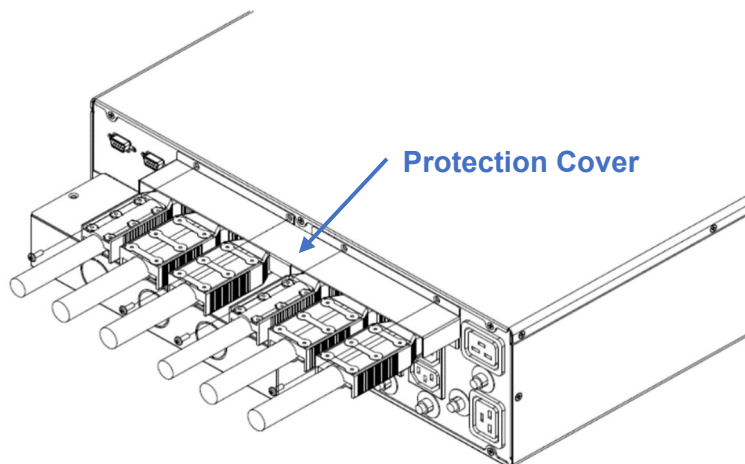

(Figure 6-16: Install the Provided Protection Cover)

Chapter 7 : Operation Procedures

1. Make sure the voltage, frequency and phase sequence of the main input and bypass input are in the operation range.
2. Make sure the breakers on the PDB's inner front panel are turned on. See **Figure 4-3**
3. Turn on the protection devices: external main input, bypass input and output breakers.
4. Refer to the instructions in Delta Amplon RT Series 15/ 20kVA UPS's **User Manual** to turn on the UPS.

Chapter 8 : Maintenance Bypass

Follow the steps below to let the connected loads be powered by manual bypass when the UPS needs maintenance.

Step 1

Check if each UPS is in bypass mode. If not, press and hold the UPS's ON/ OFF button (🔌) for 3 seconds, release it after you hear one beep, use the UPS's Scrolling Up or Down button (⬆️ / ⬇️) to select 'Yes' and press the UPS's Enter button (👉) to confirm your selection. After that, the inverter will be off, and the UPS will transfer to run in bypass mode.

Step 2

Loosen the three screws on the PDB's inner front panel to remove the warning cover plate of the manual bypass switch. See **Figure 8-1**.



NOTE:

*1 To operate the breakers on the PDB's inner front panel, please remove the PDB's front cover first. See **Figure 4-2**. Please note that after installation, the four screws on the PDB's front cover should be removed. The PDB's front cover should be fixed only by the two clips and can be open by hands anytime.

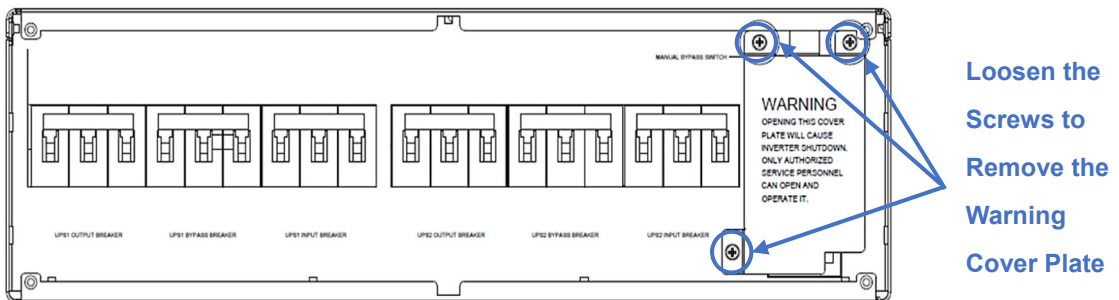

(Figure 8-1: Remove the Warning Cover Plate from the PDB's Inner Front Panel)

Step 3

Behind the warning cover plate, there is a manual bypass detector (see **Figure 8-2**) that will be automatically activated to send the UPS a message to make it transfer to bypass mode once the warning cover plate is removed. After you confirm that the UPS is running in bypass mode, turn on the manual bypass switch (see **Figure 8-2**). From now on, the connected loads are powered directly by the AC source.

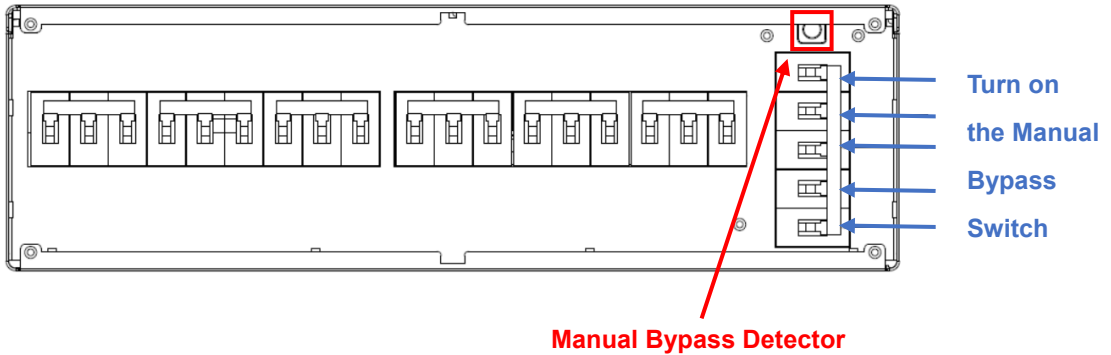

(Figure 8-2: Turn on the PDB's Manual Bypass Switch)

Step 4

Turn off all the output/ bypass/ input breakers on the PDB's inner front panel. Please also refer to **Figure 4-3** for details.

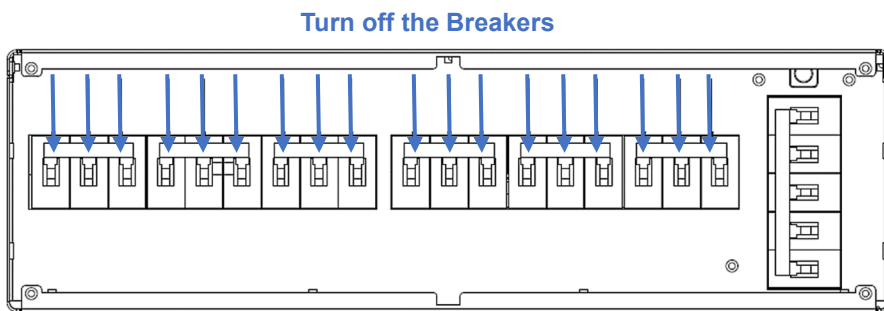

(Figure 8-3: Turn off the Breakers on the PDB's Inner Front Panel)

Step 5

Remove the provided protection cover above the connected power cables on the PDB's rear panel (see **Figure 8-4**) and disconnect the power cables as well as PDB communication cable (and the UPS's parallel cables) from the PDB's rear panel. See **Figure 8-5**. Only qualified service personnel can disconnect these power cables.

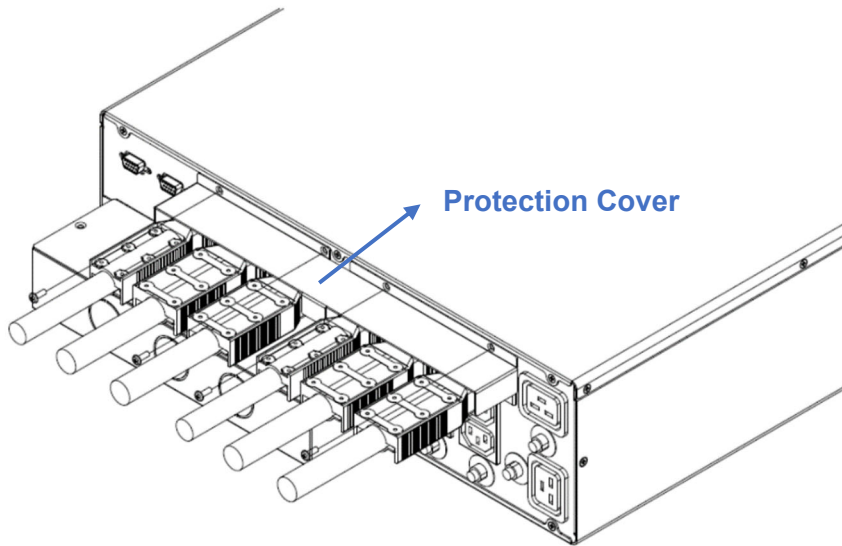

(Figure 8-4: Remove the Protection Cover from the PDB's Rear Panel)

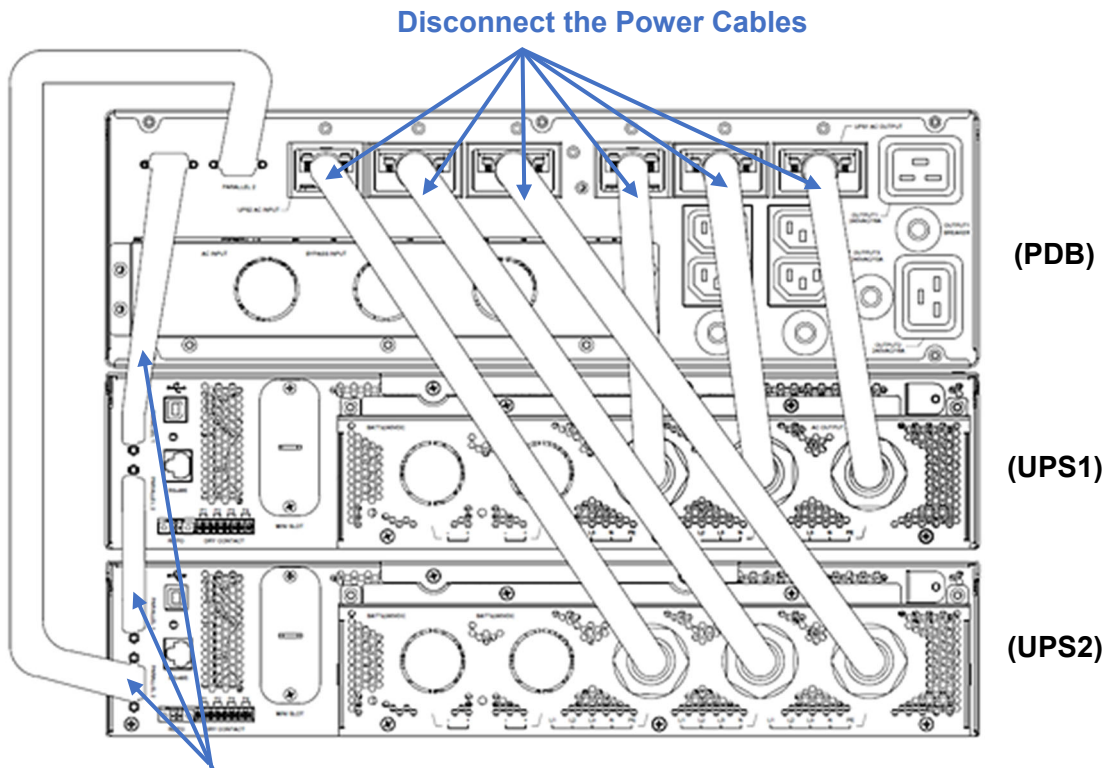

(Figure 8-5: Disconnect the Power Cables, PDB Communication Cable (and UPS Parallel Cables) from the PDB's Rear Panel)

Step 6

Reinstall the two plates that were originally fixed on the PDB's rear panel to protect the ports before shipment. For details about the ports, please refer to **Figure 4-4**.

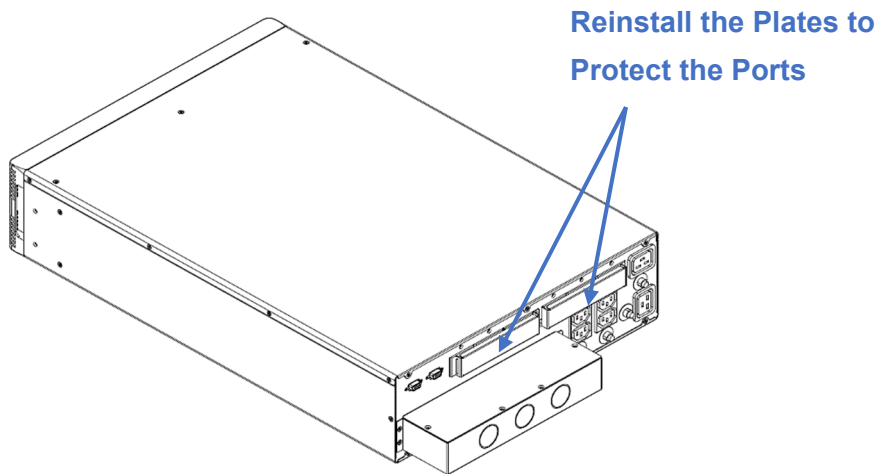

(Figure 8-6: Reinstall the Plates to Protect the Ports on the PDB's Rear Panel)



NOTE:

You should remove the connection between the PDB and the UPS(s) before disconnecting the external battery pack of the UPS(s). Regarding disconnection between the UPS and the Delta's optional battery pack, please refer to the Delta lead-acid/ lithium-ion battery pack's ***User Manual***.

Appendix 1 : Technical Specifications

Model		PDB-RT-10/15/20K
Input	Nominal Voltage	220/380 Vac, 230/400 Vac, 240/415 Vac
	Nominal Current	63A, 60.4A, 57.9A (3Φ per phase)
	Connection	Terminal block
Bypass	Nominal Voltage	220/380 Vac, 230/400 Vac, 240/415 Vac
	Nominal Current	91.8A, 87.9A, 84.3A (1Φ)
		63A, 60.4A, 57.9A (3Φ per phase)
Connection	Terminal block	
Output	Nominal Voltage	220/380 Vac, 230/400 Vac, 240/415 Vac
	Nominal Current	90.9A, 87A, 83.4A (1Φ)
		60.6A, 58A, 55.6A (3Φ per phase)
	Connection	Terminal block, IEC C19 × 2, IEC C13 × 4
	Max. Load	20000VA/20000W (1Φ)
13334VA/13334W (3Φ per phase)		
Communication Interfaces		DB9 port × 2
Physical	Dimensions (W × D × H)	440 mm × 725 mm × 130.3 mm (17.3" × 28.5" × 5.1")
	Weight	16 kg (35.3 lb)
Environment	Operating Altitude	0 m ~ 3000 m (0 ft ~ 9843 ft); 0 m ~ 1000 m (0 ft ~ 3281 ft) without derating
		Operating Temperature
	Storage Temperature	-15°C ~ 55°C (5°F ~ 131°F)
	Relative Humidity	5% ~ 95% (non-condensing)



NOTE:

1. When the PDB is connected to the UPS, the operating temperature of the PDB and the UPS is 0°C ~ 40°C (32°F ~ 104°F).
2. Please refer to the rating label for the safety rating.
3. All specifications are subject to change without prior notice.

Appendix 2 : Warranty

Seller warrants this product, if used in accordance with all applicable instructions, to be free from original defects in material and workmanship within the warranty period. If the product has any failure problem within the warranty period, Seller will repair or replace the product at its sole discretion according to the failure situation.

This warranty does not apply to normal wear or to damage resulting from improper installation, operation, usage, maintenance or irresistible force (i.e. war, fire, natural disaster, etc.), and this warranty also expressly excludes all incidental and consequential damages.

Maintenance service for a fee is provided for any damage out of the warranty period. If any maintenance is required, please directly contact the supplier or Seller.



WARNING:

The individual user should take care to determine prior to use whether the environment and the load characteristic are suitable, adequate or safe for the installation and the usage of this product. The User Manual must be carefully followed. Seller makes no representation or warranty as to the suitability or fitness of this product for any specific application.

No. : 501327820101

Version : V 1.1

Release Date : 2020_5_13

- Global Headquarter

Taiwan

Delta Electronics Inc.
39 Section 2, Huandong Road, Shanhua District,
Tainan City 74144, Taiwan
T +886 6 505 6565
E ups.taiwan@deltaww.com

- Regional Office

The United States

Delta Electronics (Americas) Ltd.
46101 Fremont Blvd. Fremont, CA 94538
T +1 510 344 2157
E ups.na@deltaww.com

Australia

Delta Energy Systems Australia Pty Ltd.
Unit 20-21, 45 Normanby Road, Notting Hill VIC 3168, Australia
T +61 3 9543 3720
E ups.australia@deltaww.com

South America

Delta Greentech (Brasil) S/A
Rua Itapeva, 26 - 3° andar Edificio Itapeva One - Bela Vista
01332-000 - São Paulo - SP - Brazil
T +55 11 3568 3850
E ups.brazil@deltaww.com

Thailand

Delta Electronics (Thailand) Public Co.,Ltd.
909 Soi 9, Moo 4, E.P.Z., Bangpoo Industrial Estate, Tambon Prakasa,
Amphur Muang-samutprakarn, Samutprakarn Province 10280, Thailand
T +662 709-2800
E ups.thailand@deltaww.com

China

Delta GreenTech (China) Co., Ltd.
238 Minxia Road, Pudong, Shanghai, 201209 P.R.C
T +86 21 5863 5678
+86 21 5863 9595
E ups.china@deltaww.com

South Korea

Delta Electronics (Korea), Inc.
1511, Byucksan Digital Valley 6-cha, Gasan-dong, Geumcheon-gu,
Seoul, Korea, 153-704
T +82-2-515-5303
E ups.south.korea@deltaww.com

Singapore

Delta Electronics Int'l (Singapore) Pte Ltd.
4 Kaki Bukit Ave 1, #05-04, Singapore 417939
T +65 6747 5155
E ups.singapore@deltaww.com

India

Delta Power Solutions (India) Pvt. Ltd.
Plot No. 43, Sector-35, HSIIDC, Gurgaon-122001, Haryana, India
T +91 124 4874 900
E ups.india@deltaww.com

EMEA

Delta Electronics (Netherlands) BV
Zandsteen 15, 2132MZ Hoofddorp, The Netherlands
T +31 20 655 09 00
E ups.netherlands@deltaww.com



5013278201