



Delta MVD3000 Series

Medium Voltage Drive



www.deltaww.com/mvd





Contents

Delta Group	1
Delta MVD3000 Series	2
Major Application	3
Major Advanced Features & Benefits	4
System Structure	5
Spec. & Parameters	7
Compliance & Standards	8
Product Selection	9
Installation Diagram	10
MVD Cooling Proposal	11
Reliability & Certificate	12
System Model Names	13
Global Sales & Services	13

Delta Group

As the world Top 1 switching power supply and energy management solution supplier, Delta Group is also the leading manufacturer in multiple product fields in the world. Delta supplies products including power supply management package solutions, video displays, industrial automation, network communication products, and recycle-energy products.

Delta Group has established business operation branches all over the world, as well as manufacturing plants in Taiwan, China Mainland, Thailand, Mexico, Japan, India, Brazil, and Europe.

As the leading supplier in electrical and electronic industries in the world, Delta Group has defined its operation mission as “Environmental Protection, Energy Saving, and Earth Caring”, and made long-lasting efforts on executing green environmental protections. Delta implemented a green manufacturing process free of lead many years ago, as well as recycling measures and waste retreatment plans.

In the past 40 years, Delta Group insisted on the operation mission of “Environmental protection, Energy Saving, and Caring for the Earth”, pursued continuous innovation, which led to its leading role in many product fields, and being listed in the TOP 50 among Asian Excellent Enterprises sponsored by Forbes.

Delta Group aims to realize environmental protection by establishing and promoting green buildings, and implementing green manufacturing processes, source recycling, and wastes retreatment plans; Delta was elected as the only Chinese enterprise listed in the Global Top 100 Low-Carbon Enterprise sponsored by CNBC. In 2010, Delta was recognized by the Anyong Award of Annual Entrepreneur, Social Responsibility Award and Award of Best Chinese Business Leader by CNBC.

More information refers to the website: www.deltaww.com



Advanced Features & Benefits

Advanced Technologies

- Adopts SVM full-control rectifier technology with a high power factor for grid access points, low amount of harmonics, higher ability to resist power disruptions, and wide range of applications.
- The MVD operates in four quadrants and implements fast load-side braking and grid-side energy feedback.
- Advanced vector control technology with and without sensor, excellent motor control performance
- Advanced automatic recognition of motor parameters, DC braking, power loss crossing, synchronous/asynchronous switching function for industrial frequency variation
- Fulfills coordinated control of multiple MVDs and satisfies diverse application requirements.
- Features multilevel technology for cascaded cells. There is no need for an output filter. The output voltage waveform is similar to that of sinusoid waves and fulfills remote motor driving under adverse conditions.

Enhanced Process & Quality Control

- Capability to produce large output torque at low speeds and during motor startup, increasing dynamic response speed and acquiring more stable motor operations and accurate control of rotation speed.
- Embedded PID controller for accurate control on flow, pressure or other varying parameters.
- Continuous operation under temporary input power loss and capability to restart automatically after grid fault.
- Configurable stall/reverse/over-speed/under-speed alarm and protection to ensure quality control
- Selectable forward/reverse rotation switching
- Friendly customer interface for easy system integration.

Control and Monitoring Functions

- Power cell bus voltage
- Power cell failure message
- Transformer Fault
- Command for rotation speed (rpm)
- Operating rotation speed (rpm)
- Input/output power, current, voltage
- Accumulated running time
- MVD status
- System bypass switches and user breaker status
- Programmable analog I/Os

- Failure alarm
- Event recording

Lower Cost of Ownership

- MVD operates in four quadrants with energies passing through the inverter to provide feedback to the grid, enhancing operation efficiency for the system and achieving the effect of energies saving.
- Optimized motor operations to ensure a high amount of energies are saved and to shorten the period required before return on investment.
- Integrated transformer that adopts method of installation with three-cable-in-and-three-cable-out to minimize amount of work needed.
- Reduces mechanical stress, eliminates pipe-hammer effect, and reduces maintenance costs.
- Multilevel voltage output and starts control of current to reduce impacts to motor.
- Synchronous switching, with one inverter to accomplish soft start of multiple motors.

Protection Functions

- Control power loss alarm/protection
- Power cell failure alarm/protection
- Input/output over-current protection
- Overload protection
- Transformer high-temperature alarm & over-temperature protection
- MVD overheat protection
- Under-/over-voltage protection
- Cooling fan abnormal alarm
- Cabinet door open protection
- Cabinet pressure alarm
- Output short-circuit protection
- Input/output phase loss protection
- Communication failure protection
- Output grounding protection
- Motor stall alarm/protection
- Motor reverse rotation alarm/protection
- Over-speed and under-speed alarm/protection

System Structure

Modular System

Each output phase for MVD3000 consists of multiple power modules connected in series to achieve the required output voltage level.

System Voltage	Cells/phase
3.3kV	3
4.16kV	4
6kV	6
6.6kV	6
10kV	9
11kV	10



System Diagram

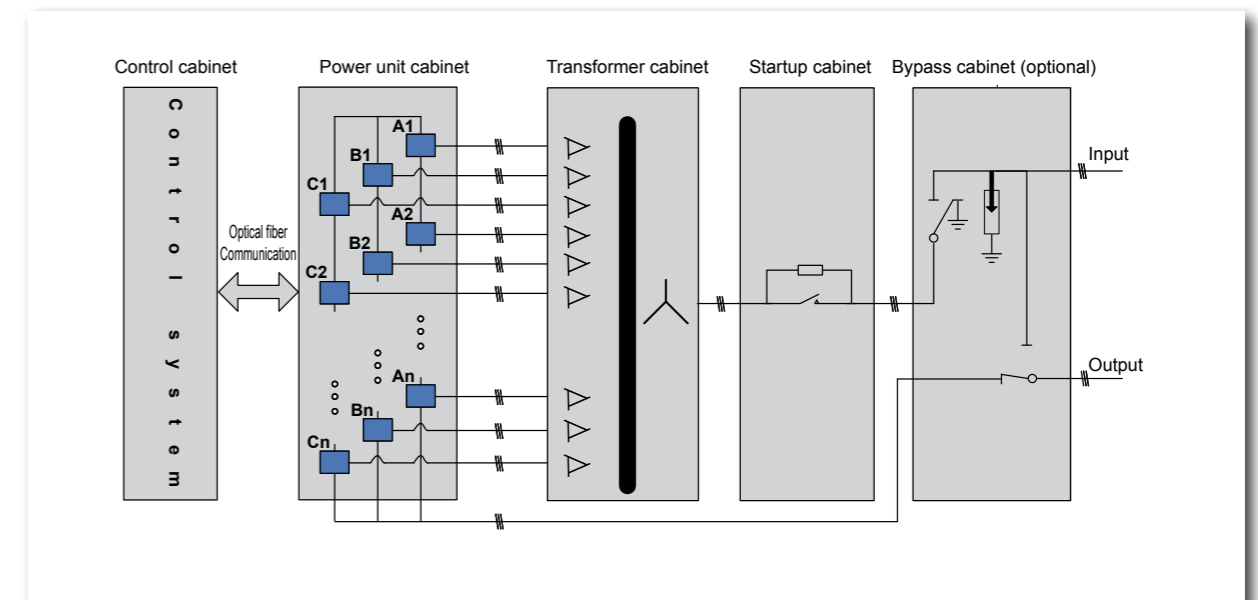

Cascaded Output Voltage Map

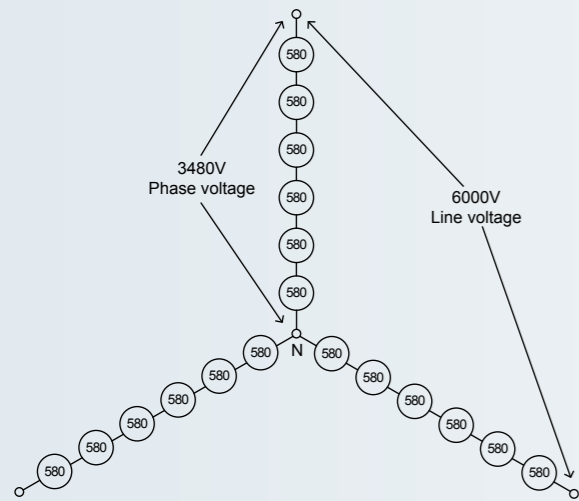

Power Unit Schematic Diagram

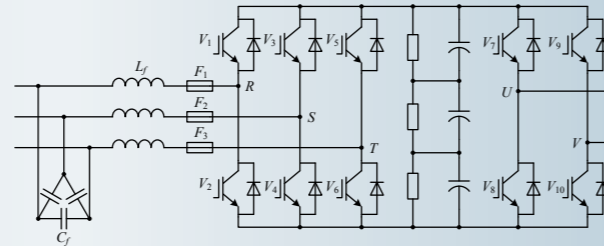

MVD3000 Specifications & Parameters

MVD3000		
System Technology	Power cell cascade technology based on IGBT	
Efficiency	>97.5% (Rated, excluding transformer)	
Input	Voltage range	-10%~+10% (normal operation), -10%~-30% (continuous operation at de-rated speed)
	Frequency	50Hz/60Hz (-2%~+2%)
	Control power supply	AC380 V (three-phase four-wire system) or AC220V, 3kVA single-phase capacity
	Input current harmonic	<5%, Meets IEEE519 standard
	Power factor	>0.97
Output	Voltage	3.3kV~11kV
	Current	38A~385A
	Max. output frequency	75Hz
	Overload capacity	120% per min or 150% per min, other options available
	Start-up torque	150% rated torque (standard), 175% and 200% available
	Speed regulating range	0%~100% (with speed sensor), 5%~100% (without speed sensor)
	Speed control resolution (steady state)	±0.01% (with speed sensor, depending on sensor accuracy), ±0.5% (without speed sensor)
	Speed response bandwidth	60 rad/s (with speed sensor), 20 rad/s (without speed sensor)
Current response bandwidth	600rad/s	
Control Parameters	Control methods	Active front-end SVM control and vector control for with-speed/speed-less sensor
	PID function	Imbedded PID regulator with parameters to be set
	Modulation method	SVPWM
	Acceleration & deceleration time	0~3000s (programmable)
	Alarms	Cell over-voltage alarm, cell control power under-voltage alarm, FRAM read-and-write alarm, cell parameter download error alarm, analog reference offline, cooling fan over-temperature, cooling fan power supply failure, cabinet pressure under-/over-voltage, control power supply failure, transformer over-temperature, AC input under-voltage, UPS failure, PLC communication failure, flying start failure
	Protections	Input/output over-current, system over-load, output short-circuit, system over-voltage, input/output phase loss, high-voltage input power down / power loss, cell under-/over-voltage, cell over-current, cell phase loss, output grounding, transformer over-temperature, power cell communication failure, system optical fiber communication failure, high-voltage cabinet door open, control power supply failure, power cell power supply failure, power cell over-temperature, power cell under-/over-voltage, power cell drive failure, external failure, over-speed protection, under-speed protection, reverse rotation protection, motor stall protection
	Functions	Speed skipping, system bypass, flying start, power loss ride through, automatic restart, adaptive acceleration and deceleration, jogging, flux-weakening, S-curve acceleration/deceleration, forward/reverse rotation, PID regulator, input under-voltage de-rating, temperature de-rating, point floating, bypass de-rating, waveform storing, auto dehumidifying (optional), variable/industrial frequency auto-switch (optional), master-slave control (optional)
	Analog input	0~10V/4~20mA, two channels (expandable)
	Analog output	0~10V/4~20mA, four channels (expandable)
	Switch input / output	10-channel input, 8-channel output (expandable)
	Human machine interface	Chinese/English touch-screen LCD display
	Display parameters	Reference speed, output speed, input/output current, operating status indication
	Communication interface	Isolated RS485, industrial Ethernet (optional), Profibus-DP (optional), GPRS (optional)
	Communication protocol	MODBUS, PROFIBUS (optional)
Environment	Operating temperature	0°C~+40°C (normal operation); +40°C~+50°C (de-rated operation)
	Storage/transportation temperature	-25°C~+70°C
	Relative humidity	5%~85%, no condensation
	Altitude	<1000m (>1000m for de-rated use)
Structure	Dimension & weight	Refer to the spec list
	Color	RAL7035 (or customize color according to user)
Cooling method	Forced air cooling	
Protection level	IP30 (standard), other configurations can be customized	

Standards

Standard No.	Standard Name
GB/T 156-2007	Standard Voltages
GB/T 1980-2005	Standard Frequencies
GB/T 2423.10-2008	Environmental testing for electric and electronic products - Part 2: Test methods - Test Fc: Vibration (sinusoidal)
GB 2681-81	Colors of insulated conductors used in electrical assembly devices
GB 2682-1981	Colors of indicator lights and push-buttons used in electrical assembly devices
GB/T 3797-2005	Electrical control assemblies
GB/T 3859.1-93	Semiconductor converters - Specification of basic requirements
GB/T 3859.2-93	Semiconductor converters - Application guide
GB/T 3859.3-93	Semiconductor converters - Transformers and reactors
GB 4208-2008	Degrees of protection provided by enclosures (IP code)
GB/T 4588.1-1996	Sectional specification: Single and double sided printed boards without plain holes
GB/T 4588.2-1996	Sectional specification: Single and double sided printed boards with plated-through holes
GB 7678-87	Semiconductor self - commutated converters
GB/T 10233-2005	Basic testing method for low-voltage switchgear and control-gear assemblies
GB 12668-90	General technical specifications for semiconductor variable-frequency speed regulating device for A.C. motor
GB/T 15139-94	General technical specifications for electrical equipment structure
GB/T 13422-92	Electrical test methods for semiconductor power converters
GB/T 14549-93	Quality of electric energy - Harmonics of public power grid
GB/T 12668.3-2003	Adjustable speed electrical power drive systems - Part 3: Product EMC standard and its specific test methods
GB/T 12668.4-2006	Adjustable speed electrical power drive systems - Part 4: General requirements - Rating specifications for A.C. adjustable speed electrical power drive systems of above 1000 V A.C. and not exceeding 35 kV
IEEE 519-1992	IEEE recommended practices and requirements for harmonic control in electrical power systems
IEC 60038	IEC standard voltages
IEC 60076-1	Power transformers - Part 1: General
IEC 60076-11	Power transformers - Part 11: Dry-type transformers
IEC 60076-12	Power transformers - Part 12: Loading guide for dry-type power transformers
IEC 60076-2	Power transformers - Part 2: Temperature rise
IEC 60076-3	Power transformers - Part 3: Insulation levels, dielectric tests and external clearances in air
IEC 60721-3-1	Classification of environmental conditions - Part 3 Classification of groups of environmental parameters and their severities - Section 1: Storage
IEC 60721-3-2	Classification of environmental conditions - Part 3: Classification of groups of environmental parameters and their severities - Section 2: Transportation
IEC 60721-3-3	Classification of environmental conditions - Part 3-3: Classification of groups of environmental parameters and their severities - Stationary use at weatherprotected locations
IEC 61000-2-4	Electromagnetic compatibility (EMC) - Part 2-4: Environment - Compatibility levels in industrial plants for low-frequency conducted disturbances
IEC 61800-3	Adjustable speed electrical power drive systems - Part 3: EMC requirements and specific test methods
IEC 61800-4	Adjustable speed electrical power drive systems - Part 4: General requirements - Rating specifications for a.c. power drive systems above 1000V a.c. and not exceeding 35kV
IEC 61800-5-1	Adjustable speed electrical power drive systems - Part 5-1: Safety requirements - Electrical , thermal and energy

Product Dimensions

6kV MVD3000 outline drawings shown below:

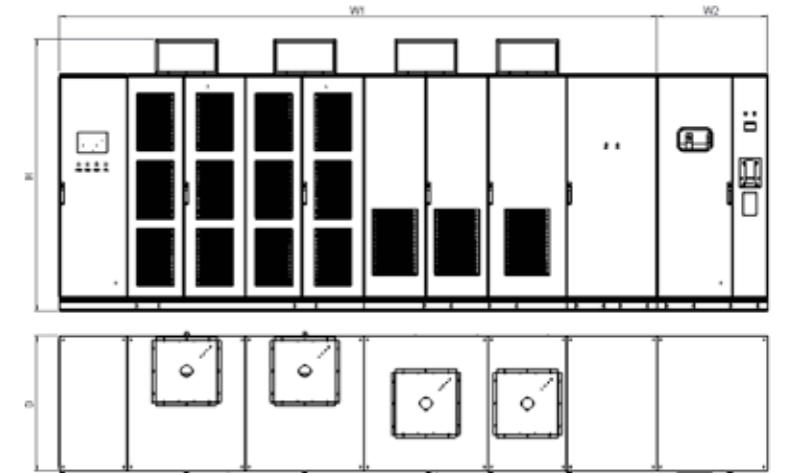

Product Selection

MVD3000										
Rated Voltage (kV)	Refer to suitable motors						Inverter model	Cabinet Dimensions (mm)		
	No overload		120% overload		150% overload			Height (H)	Width (W1)	Depth (D)
	P(kW)	I(A)	P(kW)	I(A)	P(kW)	I(A)				
6	315	38	263	32	210	25	MVD30C038A□S□	2400	5000	1200
	400	48	333	40	267	32	MVD30C048A□S□	2400	5000	1200
	500	60	417	50	333	40	MVD30C060A□S□	2400	5300	1200
	630	76	525	63	420	51	MVD30C076A□S□	2400	5300	1200
	800	96	667	80	533	64	MVD30C096A□S□	2400	5300	1200
	1000	120	833	100	667	80	MVD30C120A□S□	2700	5900	1400
	1250	150	1042	125	833	100	MVD30C150A□S□	2700	5900	1400
	1400	168	1167	140	933	112	MVD30C168A□S□	2700	5900	1400
	1600	192	1333	160	1067	128	MVD30C192A□S□	2700	5900	1400
	1800	217	1500	180	1200	144	MVD30C217A□S□	2700	8850	1400
	2000	241	1667	200	1333	160	MVD30C241A□S□	2700	8850	1400
	2500	301	2083	251	1667	200	MVD30C301A□S□	2700	8850	1400
	3200	385	2667	321	2133	257	MVD30C385A□S□	2700	8850	1400
	10	527	38	439	32	351	25	MVD30E038A□S□	2400	5900
665		48	554	40	443	32	MVD30E048A□S□	2400	5900	1200
831		60	693	50	554	40	MVD30E060A□S□	2400	6650	1200
1053		76	878	63	702	51	MVD30E076A□S□	2400	6650	1200
1330		96	1109	80	887	64	MVD30E096A□S□	2400	6650	1200
1663		120	1386	100	1109	80	MVD30E120A□S□	2700	7400	1400
2078		150	1732	125	1386	100	MVD30E150A□S□	2700	7400	1400
2328		168	1940	140	1552	112	MVD30E168A□S□	2700	7400	1400
2660		192	2217	160	1774	128	MVD30E192A□S□	2700	7400	1400
3007		217	2506	181	2005	145	MVD30E217A□S□	2700	11800	1400
3339		241	2783	201	2226	161	MVD30E241A□S□	2700	11800	1400
4171		301	3476	251	2781	201	MVD30E301A□S□	2700	11800	1400
5335		385	4446	321	3556	257	MVD30E385A□S□	2700	11800	1400

Note: 1. Bypass cabinet is customer-selectable with the W2 size of 980 mm.

2. The table above is for the standard dimension of the MVD3000 high-voltage inverter. Final dimension for the product is designed and determined by our technical staffs based on customer needs.

Installation Diagram

Installation foundation

For wiring safety and convenience, it is recommended to install the MVD cabinet on a cable trench as shown in the drawing below.

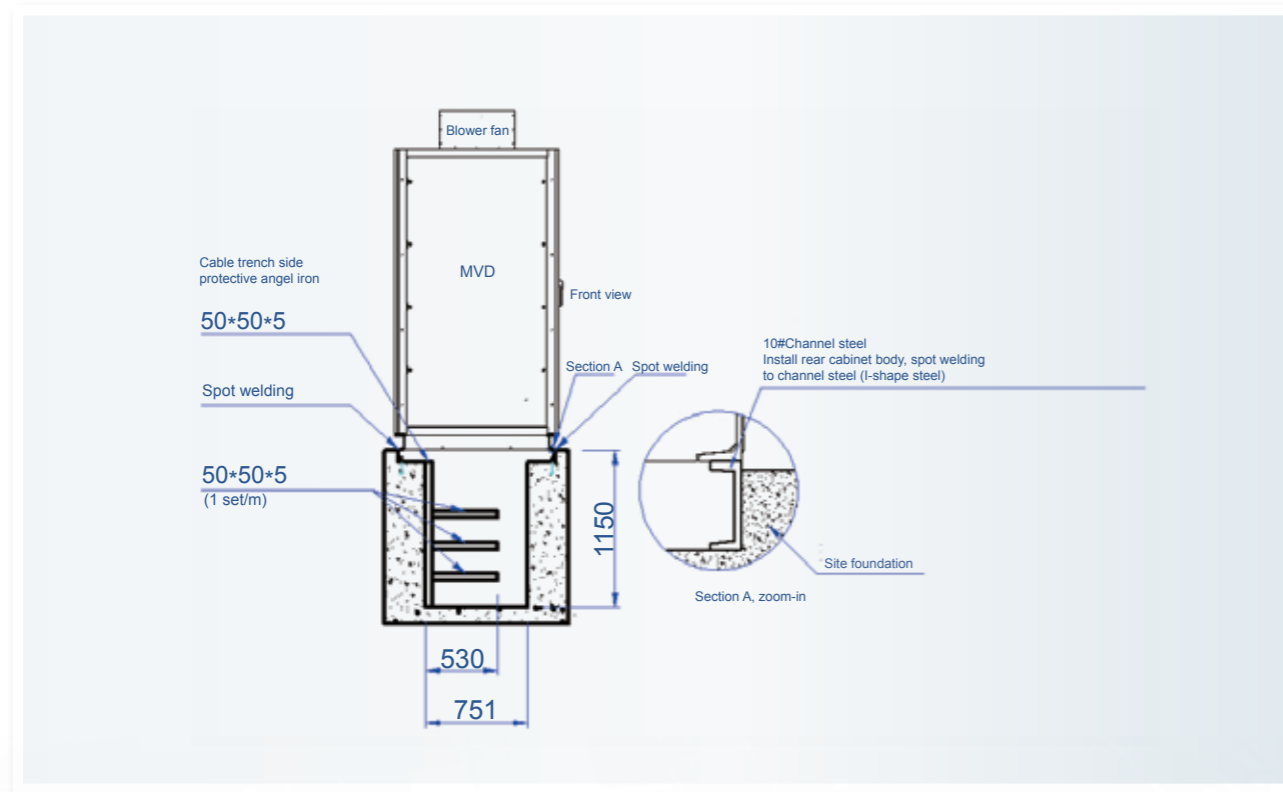

Cross-section of cable and installation trench

Detailed requirements:

1. It is recommended to set the minimum length of cable trench as the total inverter length, adding 1m to the left and right for easy cabling and maintenance.
2. The inverter is placed on the trench rail using 10# channel steel (use 16# channel steel if the MVD power $\geq 1600\text{kW}$, and 18# double-T steel if the MVD power $> 4000\text{kW}$).
3. Reserve free space on top and front of the MVD cabinet, so that the distance between cabinet top and ceiling is $\geq 800\text{mm}$, and the distance between cabinet front and walls is $\geq 1500\text{mm}$.
4. For ventilation and maintenance convenience, the distance from the rear of the dry-type transformer cabinet and the back wall shall be $\geq 1000\text{mm}$.

MVD cooling proposal

There are three possible cooling solutions, which are open-air-duct cooling, sealed air condition cooling, and air condition with air-duct cooling.

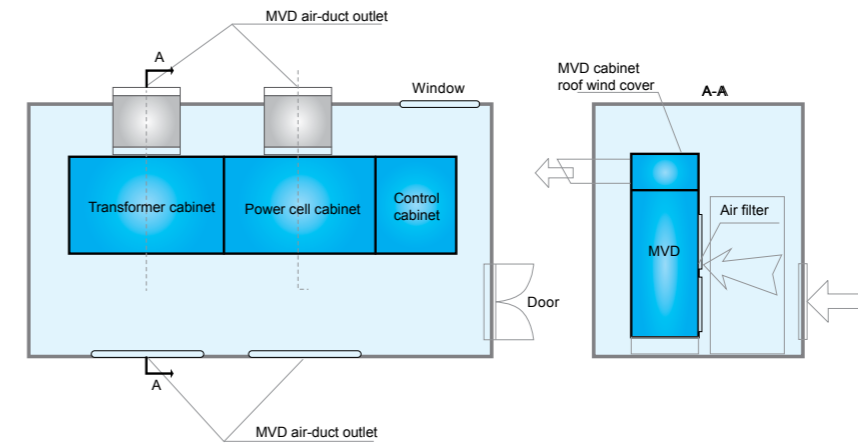

Open-air-duct cooling

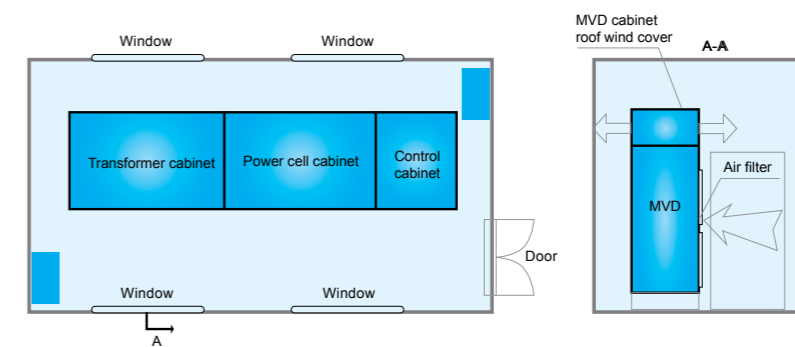

Sealed-air-conditioning cooling

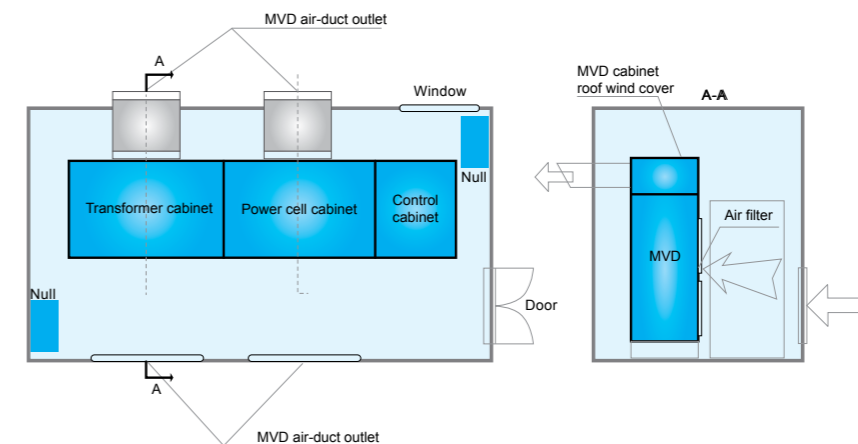

Air-duct & air-conditioning cooling

Reliability & Certification

Delta provides quality assurance through rigorous inspection and testing based on international standards. To ensure that the drive operates as predicted upon start-up, Delta Electronics has built a state-of-the-art, multi-megawatt test facility for full load capacity and full load burn-in verification. A detailed test procedure reduces start-up time during installation and commissioning in the field.

Advanced test methods and equipment



• High Voltage Distribution Cabinet System



• Inverter to accompany in test



• Central control room



• Burn-in Chamber



• Temperature control test chamber



• Motor-Generator Groups

International certificates



ISO 9001:2008



ISO 14001:2004



OHSAS 18001:2007



QC 080000:2007



TL 9000 R5.0



CE (EMC)

System Model Names

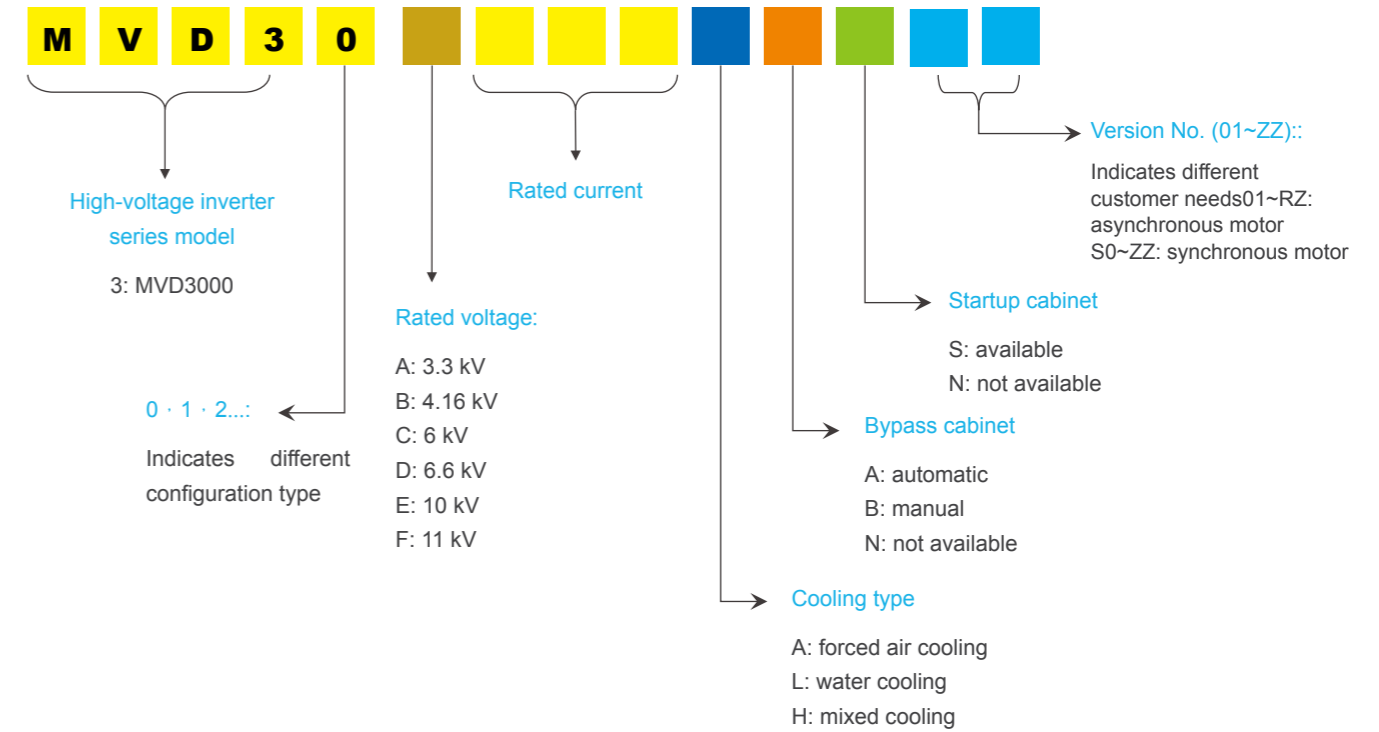

Global Sales & Service

The warranty period is one year counted from receiving the equipment at customer's site. During the warranty period, Delta will provide replacement of defective parts and repairs. Worldwide service capability ensures response in less than 8 hours, arrival at site in less than 24 hours and troubleshooting in less than 48 hours.





Smarter. Greener. Together.

Europe, Middle East, Africa

Czech

Delta Energy Systems (Czech Republic),
spol.s r.o. Litevská 1174/8
T +420 272 019 330
F +420 271 751 799

Finland

Delta Energy Systems (Finland) Oy
Juvan teollisuuskatu 15
T +358 9 8496 6421
F +358 9 84 96 6100

France

Delta Energy Systems (France) S.A.
Route de Longjumeau
T +33 1 69 102 434
F +33 1 69 341 019

Germany

Delta Energy Systems (Germany) GmbH
Coesterweg 45
T +49 2921 987 582
F +49 2921 987 404

UK

Delta Electronics Europe
1 Redwood Court
Peel Park Campus
East Kilbride, G74 5PF
T +44 1355 588 888
F +44 1355 588 889

Italy

Delta Energy Systems (Italy) Socio unico s.r.l.
Via Maggio, 6
T +39 051 733 045
F +39 051 731 838

Poland

Delta Energy Systems (Poland) Sp. z.o.o.
23 Poleczki Str.
T +48 22 335 26 00
F +48 22 335 26 01

Russia

Delta Energy Systems LLC
Vereyskaya Plaza II, office 401
T +7 495 644 3240
F +7 495 644 3241

Spain

Delta Energy Systems (Spain) S.L.
Telecom Power
Calle Luis I nº 60, Nave 1a
P.I. de Vallecas
E-28031 Madrid
T +34 91 223 74 20
F +34 91 332 90 38

Slovakia

Delta Energy Systems (Bratislava) spol.s.r.o.
Botanická 25/A
T +421 2 65411 258
F +421 2 65411 283

Sweden

Delta Energy Systems (Sweden) AB
P.O. Box 3096
T +46 470 70 68 07
F +46 470 70 68 90

Switzerland

Delta Energy Systems (Switzerland) AG
Freiburgstrasse 251
CH-3018 Bern-Bümpliz
T +41 31 998 53 11
F +41 31 998 54 85

Turkey

Delta Greentech Elektronik San. LTD. STI.
Serifali Mevkii Barboros Bulvari Söylesi Sok.
No:19
K:1 34775, Y.Dudullu-Ümraniye-istanbul
T +90 216 499 9910
F +90 216 499 8070

United Arab Emirates

Delta Energy Systems AG (Dubai BR)
Al Maktoum Road, Al Rigga Palace Building,
Suite 504, P.O.Box 185668, Dubai, U.A.E.
T +971 4 224 8595
F +971 4 224 8596

South Africa

Delta Energy Systems (South Africa)
P.O. Box 3470 Brits
0250 Republic of South Africa (ZAR)

Americas

Brazil

Delta Greentech (Brazil) S.A.
Rua Itapeva, Nº 26 - 3º andar
01332-000 - São Paulo - SP - Brazil
T +55 11 3568 3850
F +55 11 3568 3865

Argentina

Delta Energy Systems
Ayacucho 720 8 A Buenos Aires
Argentina
T +5411 4372 3105

Colombia

Delta Greentech S.A.
Sales Office Región Andina:
CL 213 114-10 Of. 14-25 - Bogotá -
Colombia
T/F +57 1 673 4927

Asian-Pacific Area

Mainland China

Delta Electronics Nanjing
No.1-2 Longzang Road, Yuhua Economic
Development Area, Nanjing
T +86 25 68573008 ext 8509
F +86 25 68905267

Delta GreenTech (China) Co. Ltd

E3 Building No.12 Yumin Zhong Road,
Chaoyang, Beijing
T +86 10 82253225 ext 6117
T +86 25 8225 2308

Taiwan

Delta Electronics Inc.
3 Tungyuan Road, Chungli Industrial
Zone, Taoyuan County 32063 Taiwan,
R.O.C.
T +886 3 452 6107 ext 6356
T +886 3 452 7314

For more information about products and sales, please consult: mvd@delta.com.tw

www.deltaww.com/mvd

20130226